

HF ALL BAND TRANSCEIVER

IC-730

MAINTENANCE MANUAL



ICOM INCORPORATED

1-6-19, Kamikurazukuri Hirano-ku, Osaka, Japan
Phone: [06] 793-5301
Telex: ICOM TR J63649

ICOM EUROPE G.M.B.H.

Himmelgeister Strass 100
4000 Duesseldorf 1
West Germany
Phone: 0211-346047
Telex: 41-8588082

ICOM AMERICA, INC.

2112 116th Avenue N.E.
Bellevue, WA 98004
Phone: [206] 454-8155
Telex: 230-152210 ICOM AMER BVUE
3331 Towerwood Dr., Suite 307
Dallas, Texas 75234
Phone: [214] 620-2781

ICOM CANADA LTD.

810 S.W. Marine Drive
Vancouver, BC Canada
Phone: [604] 321-1833
Telex: 21-454315

ICOM AUSTRALIA, PTY. Ltd.

7 Duke Street, Windsor 3181
Victoria Australia
Phone: [03] 529-7582
Telex: 71-35521 ICOMAS AA35521

TABLE OF CONTENTS

SECTION	1.	SPECIFICATIONS	1 - 1
SECTION	2.	OPERATING CONTROLS	2 - 1 ~ 4
SECTION	3.	CIRCUIT DESCRIPTION	3 - 1 ~ 8
	3 - 1	RECEIVING CIRCUITS	3 - 1
	3 - 2	TRANSMITTING CIRCUITS	3 - 3
	3 - 3	1ST LOCAL OSCILLATOR CIRCUITS	3 - 6
	3 - 4	DISPLAY UNIT	3 - 8
SECTION	4.	INSIDE VIEWS	4 - 1 ~ 4
SECTION	5.	BLOCK DIAGRAM	5 - 1
SECTION	6.	OPTIONS INSTALLATION	6 - 1 ~ 9
SECTION	7.	MECHANICAL PARTS AND DISASSEMBLY	7 - 1 ~ 23
SECTION	8.	MAINTENANCE AND ADJUSTMENT	8 - 1 ~ 19
	8 - 1	MEASURING INSTRUMENTS REQUIRED FOR ADJUSTMENT	8 - 1
	8 - 2	PLL ADJUSTMENT	8 - 2
	8 - 3	RECEIVER ADJUSTMENT	8 - 11
	8 - 4	TRANSMITTER ADJUSTMENT	8 - 13
SECTION	9.	VOLTAGE (CIRCUIT) DIAGRAMS	9 - 1 ~ 14
SECTION	10.	PARTS LIST	10 - 1 ~ 20
SECTION	11.	SCHEMATIC DIAGRAM	11 - 1
SECTION	12.	BOARD LAYOUT	SEPARATE

SECTION 1 SPECIFICATIONS

GENERAL

Number of Semiconductors:

Transistors	71
FET	15
IC (Includes CPU)	25
Diodes	212

Frequency Coverage:

3.5MHz ~ 4.0 MHz
7.0MHz ~ 7.3 MHz
10.0MHz ~ 10.5 MHz (Receive Only)
14.0MHz ~ 14.35MHz
18.0MHz ~ 18.5 MHz (Receive Only)
21.0MHz ~ 21.45MHz
24.5MHz ~ 25.0 MHz (Receive Only)
28.0MHz ~ 29.7 MHz

Frequency Control:

CPU based 10Hz step Pre-mixed synthesizer.
Independent Transmit-Receive Frequency Available on same band.

Frequency Readout:

6 digit 100Hz readout.

Frequency Stability:

Less than 500Hz after switch on 1 min to 60 mins, and less than 100Hz after 1 hour. Less than 1KHz in the range of -10°C to $+60^{\circ}\text{C}$.

Power Supply Requirements:

DC 13.8V $\pm 15\%$ Negative ground Current drain 20A max. (at 200W input)
AC power supply is available for AC operation.

Antenna Impedance:

50 ohms Unbalanced

Weight:

6.4 Kg

Dimensions:

94mm(H) x 241mm(W) x 275mm(D)

TRANSMITTER

RF Power:

SSB (A ₃ J)	200 Watts PEP input
CW (A ₁)	200 Watts input
Continuously Adjustable Output power	10 Watts ~ Max.
AM (A ₃)	40 Watts output
Continuously Adjustable Output power	10 Watts ~ 40 Watts

Emission Mode:

A ₃ J	SSB (Upper sideband and Lower sideband)
A ₁	CW
A ₃	AM

Harmonic Output:

More than 50dB below peak power output

Spurious Output:

More than 50dB below peak power output

Carrier Suppression:

More than 50dB below peak power output

Unwanted Sideband:

More than 55dB down at 1000Hz AF input

Microphone:

Impedance 1300 ohms

Input Level 120 millivolts typical

Dynamic or Electret Condenser Microphone with Preamplifier

RECEIVER

Receiving System:

Quadruple Conversion Superheterodyne with continuous Pass-Band Shift Control.

Receiving Mode:

A₁, A₃J (USB, LSB), A₃

IF Frequencies:

1st	39.7315MHz
2nd	9.0115MHz
3rd	455KHz
4th	9.0115MHz

with continuous Pass-Band Shift Control.

Sensitivity:

SSB, CW	Less than 0.3 microvolts for 10dB S+N/N
AM	Less than 0.6 microvolts for 10dB S+N/N

Selectivity:

SSB, CW	2.4KHz at -6dB
	4.8KHz at -60dB
AM	6.0KHz at -6dB
	18.0KHz at -60dB

CW-N

(when optional crystal filter installed)

600Hz at -6dB
1.5KHz at -60dB

(when optional AF filter installed)

150Hz at -6dB
1100Hz at -40dB

Spurious Response Rejection Ratio:

More than 60dB

Audio Output:

More than 2 Watts

Audio Output Impedance:

8 ohms

Specifications are approximate and are subject to change without notice or obligation.

SECTION 2 OPERATING CONTROLS

FRONT PANEL

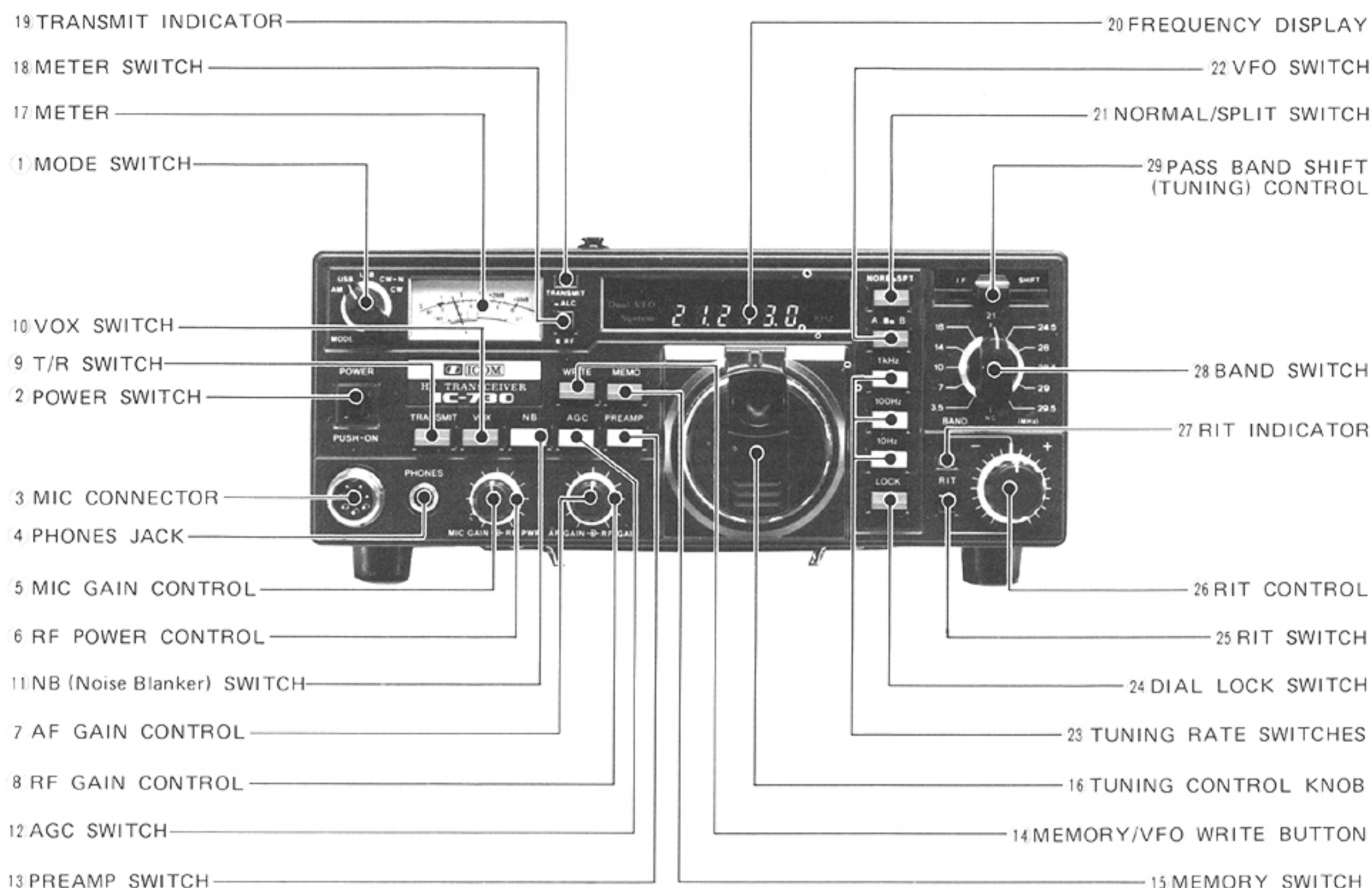

CONTROLS UNDER THE ACCESS COVER

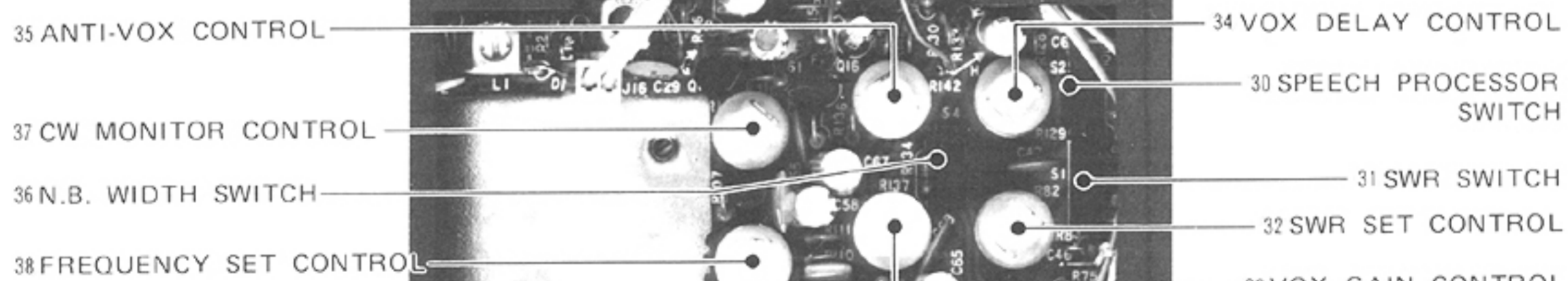

REAR PANEL CONNECTIONS



FRONT PANEL

1. MODE SWITCH

This switch selects the mode of operation for both transmit and receive.

- USB Upper Sideband, mainly for 10, 14, 18, 21, 24 and 28MHz bands.
- LSB Lower Sideband, mainly for 3.5 and 7MHz bands.
- CW Continuous Wave, for CW operation on all bands.
- CW-N Narrow CW. The narrow crystal filter is automatically turned ON in this position to improve selectivity when receiving. (When optional crystal filter is installed)
- AM Amplitude Modulation.

2. POWER SWITCH

The POWER SWITCH is a push-lock type switch which controls the input DC power to the IC-730. When the external AC power supply (IC-PS15) is used, the switch also acts as the AC power supply switch. When the switch is pushed in and locked, power is supplied to the set. When the switch is pushed again and released, power is cut to all circuits except the PA unit. (When the BC-10A is used, power will also be supplied to the CPU.

3. MIC CONNECTOR

Connect the supplied microphone or optional microphone, IC-SM5 or IC-HM10 to this jack. If you wish to use a different microphone.

4. PHONES JACK

Accepts a standard 1/4 inch headphone plug for headphones of 4 ~ 16 ohms. Stereo phones can be used without modification.

5. MIC GAIN CONTROL

Adjusts the level of modulation according to the input of the microphone. Clockwise rotation increases the microphones gain. As the input will vary with different microphones and different voices, the knob should be turned until the Meter needle, in the ALC mode, begins to move slightly within the ALC zone. In SSB and AM modes, when the speech processor is in use, the MIC GAIN CONTROL sets the clipping limits, while the RF POWER CONTROL sets the RF drive level to the maximum power level, where ALC starts at the saturation point of the amplifiers.

6. RF POWER CONTROL

Controls the RF output power 10 Watts to maximum (SSB: 100 Watts PEP, CW: 100 Watts, AM: 40 Watts). Clockwise rotation increases the output power.

7. AF GAIN CONTROL

Controls the audio output level in the receive mode. Clockwise rotation increases the level.

8. RF GAIN CONTROL

Controls the gain of the RF section in the receive mode. Clockwise rotation gives the maximum gain. As the control is rotated counterclockwise, the needle of the METER rises, and only signals stronger than the level indicated by the needle will be heard.

9. T/R (TRANSMIT/RECEIVE) SWITCH

This switch is for manually switching from transmit to receive and vice versa. Set the switch to RECEIVE (out) and the IC-730 is in the receive mode. Set the switch to TRANSMIT (in) and it switches to transmit. When switching with the PTT switch on the microphone or with the VOX switch set to ON, the T/R switch must be in the RECEIVE position.

10. VOX SWITCH

This switches the VOX circuit ON and OFF. When it is in the ON (in) position, in SSB, T/R switching is accomplished by means of a voice signal. In CW operation, semi-break-in switching by means of keying is possible.

11. NB (NOISE BLANKER) SWITCH

When pulse type noise such as automobile ignition noise is present, set this switch to the ON (in) position. The noise will be reduced to provide comfortable reception.

The blanking time can be selected NARROW and WIDE, by the NB WIDTH switch under the access cover. It will be effective against any type noises.

12. AGC (AUTOMATIC GAIN CONTROL) SWITCH

For changing the time-constant of the AGC circuit. With the switch in the AGC position (out) the AGC voltage is released slowly, and thus is suitable for SSB reception. With the switch in the FAST (in) position, the AGC voltage is released faster, and the AGC is suitable for stations suffering from fast fading or when operating in the CW mode.

13. PREAMP SWITCH

Switches the preamplifier for the receiver.

14. MEMORY/VFO WRITE BUTTON

By pushing this button, A VFO's frequency is written into Memory, or one VFO's frequency is transferred to the other VFO.

15. MEMORY SWITCH

Push this switch when you wish to write a frequency into memory, or to call a memorized frequency.

16. TUNING CONTROL KNOB

Rotating the TUNING CONTROL KNOB clockwise increases the frequency, while rotating it counterclockwise decreases the frequency. The frequency is changed in 10Hz, 100Hz or 1KHz steps which is according to the TUNING RATE switches. One complete rotation of the tuning knob results in a 1KHz frequency increase or decrease in 10Hz steps, 10KHz in 100Hz steps and 100KHz in 1KHz steps.

17. METER

When in the receive mode the meter acts as an S meter regardless of the position of the meter select switch. Signal strength is indicated on a scale of S1-S9, and S9 to S9+60dB.

In the transmit mode the meter has two functions which are selected by the Meter Switch (18). They are as follows:

Po; Indicates the relative output power. SWR can be measured by placing the switch located inside the top cover to the SWR position.

ALC; In this position the meter functions when the RF output reaches a certain level.

18. METER SWITCH

Selects meter function in the transmit mode.

19. TRANSMIT INDICATOR

Illuminates when the transceiver is in the transmit mode.

20. FREQUENCY DISPLAY

The frequency of the IC-730 is displayed on a luminescent display tube. Since the 1MHz and 1KHz decimal points are displayed, the frequency can easily be read. The frequencies indicated are the carrier frequencies of each mode in AM, USB, LSB and CW.

Remember, if you turn the RIT SWITCH ON to change the receive frequency and rotate the RIT CONTROL knob, the frequency displayed will not change.

21. NORMAL/SPLIT (TRANSCIVE/SPLIT) SWITCH

Selects the relationship of the two VFO's. In the NORM (out) position, one VFO is for both transmit and receive. In the SPT (in) position, one VFO is for transmit and the other is for receive.

22. VFO SWITCH

You can select either of the built-in two VFO's with this switch. It also selects the relationship of the two VFO's with the NORMAL/SPLIT switch. The switch performs the following operations according to its position.

A. (NORMAL) Selects the "A" VFO for both transmit and receive.

A. (SPLIT) Selects "A" VFO for receive and "B" VFO for transmit.

B. (NORMAL) Selects the "B" VFO in both transmit and receive.

B. (SPLIT) Selects "B" VFO for receive and "A" VFO for transmit.

23. TUNING RATE SWITCHES

The small vernier marks on the tuning knob are changed to correspond to 10Hz, 100Hz or 1KHz steps which is selected by pushing the switch either 10Hz, 100Hz or 1KHz.

24. DIAL LOCK SWITCH

After the IC-730 is set to a certain frequency for rag chewing, mobile operation, etc., push the DIAL LOCK switch the VFO is electronically locked at the displayed frequency, thus inactivating the operation of the tuning knob. To change frequency, the dial lock must first be disengaged by pushing and releasing the DIAL LOCK switch again.

25. RIT SWITCH

Switches the RIT circuit ON and OFF.

26. RIT CONTROL

Shifts the receive frequency $\pm 800\text{Hz}$ either side of the transmit frequency. When the RIT is ON, the RIT INDICATOR is illuminated. Rotating the control to the (+) side raises the receive frequency, and rotating to the (-) side lowers the receive frequency. The frequency shifted by turning the RIT Control is not indicated on the frequency display.

27. RIT INDICATOR

Illuminates when RIT is turned ON.

28. BAND SWITCH

The BAND SWITCH is an 11 position rotary switch used for selecting one of the 500KHz segments. The selectable bands are 3.5KHz, 7MHz, 10MHz, 14MHz, 18MHz, 21MHz, 24MHz and 28MHz. (28MHz band is separated to four 500KHz segments.)

29. PASS-BAND SHIFT (TUNING) CONTROL

Allows continuous shifting of the pass-band from upper or lower side in SSB and CW. This will reduce interference by a nearby signal. When the optional crystal filter FL-30 is installed, this control allows continuous tuning of the pass-band selectivity by moving the filter up to 800Hz from the upper or lower side in SSB and CW. Not only improves selectivity, but also can improve the audio tone. Normal position is in the center position and is 2.4KHz wide in SSB.

CONTROLS UNDER THE ACCESS COVER

30. SPEECH PROCESSOR SWITCH

Switches the speech processor circuit ON and OFF. This circuit enables greater talk power and better results in DX operation.

31. SWR SWITCH

When measuring SWR, calibration SET and SWR reading functions are selected with this switch. When reading SWR make sure the METER switch on the front panel is in the RF position.

32. SWR SET CONTROL

This control calibrates the meter needle to the SWR SET position when you want to determine the value of SWR. The METER switch must be in the RF position and the set must be transmitting a carrier.

33. VOX GAIN CONTROL

This control adjusts input signal level via the microphone to the VOX circuit. For VOX operation in SSB, adjust the control so that the VOX circuit will operate with normal speech.

34. VOX DELAY (VOX time constant) CONTROL

This controls the transmit to receive switching time. Adjust it so transmit to receive switching will not occur during short pauses in normal speech.

35. ANTI-VOX CONTROL

In VOX (SSB) operation, the VOX circuit may be operated by sound from the speaker causing a switch to transmit. This trouble can be prevented by adjusting the input level of the ANTI-VOX circuit with this control along with the VOX gain control so that the VOX circuit only operates from the operator's voice, not by sound from the speaker.

36. N.B. WIDTH SWITCH

Switches the blanking action time of the noise blanker NARROW (short) and WIDE (long). Set the switch in the NARROW or WIDE position according to incoming noise.

37. CW MONITOR (MONI) CONTROL

This control adjusts the audio volume of the side tone (monitor) audio during CW transmit operation. Adjust it to your desired level for easy listening.

38. FREQUENCY SET CONTROL

This control is for fine adjustment of the reference frequency of the PLL unit, which is local oscillator frequency. Do not turn it unless you want to change the frequency.

REAR PANEL CONNECTIONS

39. MEMORY BACKUP (RL) TERMINAL

For connection of a 9 ~ 12V DC power supply. For mobile installation connection to the vehicle's battery can be made the current drain is low, for fixed installation use of the BC-10A is recommended.

By changing an internal connector, this terminal can be used for Transmit/Receive relay control terminal. This terminal can be used to switch 24V 1A DC. Don't exceed this limit.

40. EXTERNAL ALC TERMINAL

This terminal can be used for input terminal of external ALC signal from a linear amplifier or transverter.

By using optional adapter, IC-EX205 and changing internal connectors, this terminal can be used for TRANSVERTER terminal.

VHF and UHF operation using a suitable transverter with the IC-730 is possible. This terminal is for Transverter connection. The output is a few milliwatts.

41. EXTERNAL SPEAKER JACK

When an external speaker is used, connect it to this jack.

Use a speaker with an impedance of 8 ohms. When the external speaker is connected, the built-in speaker does not function.

42. KEY JACK

For CW operation, connect the key here. For electronic keying the terminal voltage must be less than 0.4V DC.

43. ACCESSORY (ACC) SOCKET

Various functions are available through the accessory socket such as modulation output, receiver output, T/R change-over, and so forth. The table below shows those terminals.

ACC SOCKET CONNECTIONS

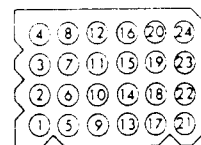

Outside view

PIN No.	FUNCTION
1.	NC (no connection)
2.	13.8 Volts DC in conjunction with the power switch operation.
3.	Connected to Push-to-talk, T/R change-over switch. When grounded, the set operates in the transmit mode.
4.	Output from the receive detector stage. Fixed output regardless of AF output or AF gain.
5.	Output from Transmitter MIC amplifier stage. (Input for MIC gain control stage.)
6.	8 Volts DC available when transmitting. (relay can not be directly actuated. Max. 5mA).
7.	Input for external ALC voltage.
8.	Ground
9.	NC
10.	8 Volts DC available when the 28MHz band is selected.
11.	Input for TRANSVERTER control. When 8 Volts DC is applied, set can operate with a transverter.
12.	Output reference voltage for band switching.
13.	Output for external band switching.
14.~24.	NC

44. ANTENNA (ANT) CONNECTOR

This is used to connect an antenna to the set. Its impedance is 50 ohms and connect with a PL-259 connector.

45. GROUND TERMINAL

To prevent electrical shock, TVI, BCI and other problems, be sure to ground the equipment through the GROUND TERMINAL. For best results use as heavy a gauge wire or strap as possible and make the connection as short as possible, even in mobile installations.

46. POWER SOCKET

For connection of the IC-PS15's DC power cord, or other suitable power supply.

SECTION 3 CIRCUIT DESCRIPTION

3 - 1 RECEIVING CIRCUITS

3 - 1 - 1 RF CIRCUITS

The receiving signal from the antenna is fed from P3 of the LPF unit to J2-1, where frequencies less than 3.5MHz are attenuated about 40dB by a High-Pass filter. This filter reduces intermodulation by strong BC signals.

The signal is usually fed to D3 directly through the contacts of RL1.

The set employs the DFM (Direct Feed Mixer) system at the front end, to get wide dynamic range.

When the PREAMP switch on the front panel is in the ON position, the signal is fed to the preamplifier. The pre-amplifier, consisting of Q1 and Q2, is designed to provide the gain of about 10dB and the intercept point of 26dBm on the entire band.

To the preamplifier, power source (13.8V) is always applied regardless if the preamplifier is turned on or off. When the PREAMP switch is pushed in, the emitter of Q3 is grounded through the switch and RL1 is actuated in the receive mode, as R8V is applied to the base of Q3 through R4. In the transmit mode or when Q8 is turned on as the TRV signal is applied to its base, the bias voltage is not applied to Q3 and RL1 is not actuated even if the PREAMP switch is pushed in.

Q5 is turned on in the transmit mode and shunts the receiver input line to ground to prevent RF feedback.

The signal passed D3 is fed to a band-pass filter which is selected by the band switching signal sent from the BAND switch through the PRE-MIX unit.

The band-pass filters are provided for each band, and one is selected for the band of operation by turning ON the diodes located at the input and output circuits of the filter. These filters have about 2dB insertion loss respectively.

The signal passed the band-pass filter is fed to the 1st mixer consisting of D4 - D7 (Doubly Balanced Mixer). This DBM has a +18dBm intercept point and 6dB insertion loss.

The 1st Local Oscillator functions at the operating frequency plus 1st IF (39.7315MHz) frequency. It is fed from the BPF unit through J6.

This 1st LO is changed with 1kHz steps and its frequency range for each band is as follows;

BAND	1st LO FREQUENCY
3.5MHz	43.1319MHz ~ 43.8315MHz
7.0MHz	46.6315MHz ~ 47.3315MHz
10.0MHz	49.6315MHz ~ 50.3315MHz
14.0MHz	53.6315MHz ~ 54.3315MHz
18.0MHz	57.6315MHz ~ 58.3315MHz

21.0MHz	60.6315MHz ~ 61.3315MHz
24.5MHz	64.1315MHz ~ 64.8315MHz
28.0MHz	67.6315MHz ~ 68.3315MHz
28.5MHz	68.1315MHz ~ 68.8315MHz
29.0MHz	68.6315MHz ~ 69.3315MHz
29.5MHz	69.1315MHz ~ 69.8315MHz

The center frequency of the 1st IF is varied 39.7305MHz - 39.7315MHz due to the 10Hz step tuning.

The 1st IF signal converted at the 1st mixer is fed to the monolithic crystal filter FI2 through D20 transmit/receive switching diode, then fed to the 1st IF amplifier Q6. FI2 has a pass band of 15kHz at -3dB points.

The 1st IF amplifier Q6 is a MOS FET, and an AGC voltage is applied to its 2nd gate. The attack time constant is determined by R36 and C67. C81 prevents VHF parasitic oscillation.

The amplified 1st IF signal is fed to FI1 through D21 transmit/receive switching diode. FI1 is the same as FI2, and totally the 2nd image rejection ratio is more than 80dB.

The 1st IF signal passed FI1 is then fed to the 2nd IF unit.

3 - 1 - 2 SECOND IF CIRCUITS

The 2nd IF signal fed from the RF unit is input to J2 and fed to the Noise Amplifier and Noise Blanker gate circuits.

The signal (39.7315MHz) is amplified with Q1 and Q2, dual gate MOS FETs, and IC1, high gain amplifier with AGC. The amplified signal is detected by D14 and then fed to IC2, voltage comparator and noise pulses are detected.

D16 generates the reference voltage, 1.2V, for IC2. D15 shunts over-voltage to prevent long delay-times.

A part of the detected signal from D14 is used for the AGC of IC2. The detected signal is fed to the base of Q7 through R42. When the detected voltage exceeds 0.6V, Q7 is turned ON which turns Q8 ON as well. 2.5V is usually applied to pin 3 of IC2. This voltage is increased when Q8 turns ON, with time constant of R34 and C42 (attack-time). This provides the AGC function. This time constant (attack-time) can be changed by the NB WIDTH switch (S4 on the MAIN unit). When it is set at the WIDE position, the time constant is determined by R46 and C42. The release-time of the AGC is determined by R34, R38, R47 and C42.

Average voltage at pin 2 of IC2 will be 0.6V due to the AGC function. Only when the detected voltage exceeds 1.2V caused by a noise pulse, pin 3 output terminal of IC2 puts out 1V pulse, and it turns ON the NB gate switch Q3.

The NB gate circuit is composed of D20, D21 and D24, and usually D20 and D21 are turned ON and D24 is OFF by the reverse voltage (6.6V) applied to the cathode. When Q3 is turned ON by a noise pulse, D24 is turned ON and

shunts the RF signals to ground. This grounds the anodes of D20 and D21, and turns them OFF. Thus the noise pulse is not fed to the following circuits.

The signal which passes the NB gate circuit is then fed to the 2nd mixer consisting of D1 - D4 diode DBM.

The 2nd local oscillator consisting of Q9 and X1 oscillates at 30.71901MHz - 30.720MHz with 10Hz steps. D19 varactor diode provides this frequency variation. A control voltage generated in the LOGIC unit and DC-amplified in the MAIN unit is applied to D19. The oscillation frequency can be adjusted by L1 and the voltage applied to D19. The 2nd local oscillator signal is about +2dBm and is fed to the L6 center tap in the 2nd mixer circuit to convert the 1st IF signal to 2nd IF (9.0115MHz) signal.

The 2nd IF signal is fed to F11 monolithic crystal filter installed as standard. When optional SSB crystal filter, FL-30, and/or CW crystal filter, FL-45 is installed, the suitable crystal filter is selected by the MODE switch.

F11 has 3kohm input/output impedance, so L8 and L9 work as step-up and step-down matching transformers respectively. F11 has lower insertion loss than other optional filters, so R15 and R28 are inserted as an attenuator. L9 is tuned by D12 varactor diode, which gives more isolation when other filters are selected. The filtered 2nd IF signal is then fed to the MAIN unit through P1.

Filter selection is made by voltages CWN (applied in CW-N mode) and CSW (applied in other modes) from the MODE switch through J4.

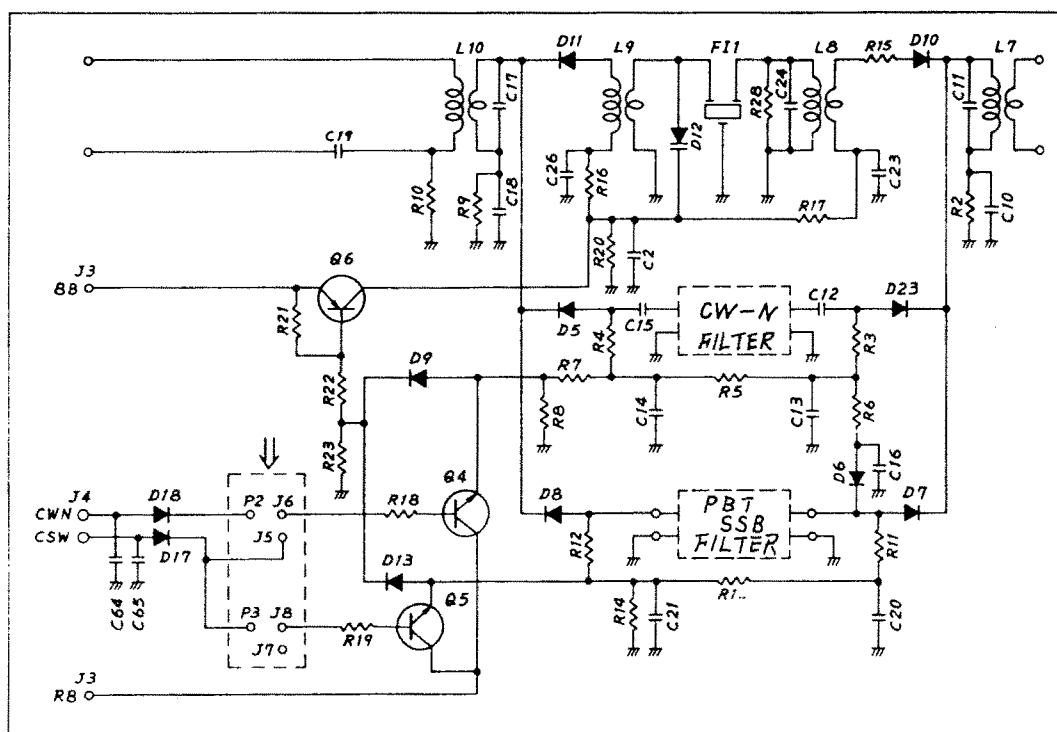

The voltage CSW is fed to the filter selection pins consisting of P3, J7 and J8, through pin 1 of J4 and D17. P3 is connected to J7 when the set has been shipped. When the optional SSB crystal filter (this provides PBT function) is installed, P3 should be connected to J8.

The voltage CWN is fed to the filter selection pins consisting of P2, J5 and J6, through pin 2 of J4 and D18. P2 is connected to J5 when the set has been shipped. When the optional CW crystal filter is installed, P2 should be connected to J6.

When any optional filters are not installed (the filter selection pins are original connections), the bases of Q4 and Q5 are not applied with any bias voltages, so Q4 and Q5 are turned OFF and both emitters are 0V. Thus D9 and D13 are turned OFF and Q6 is turned ON, and D10 and D11 are turned ON and F11 is selected in any modes.

When the optional SSB crystal filter is installed and P3 is connected to J8, Q5 is turned ON and R8V is applied to D7 and D8, and D7 and D8 are turned ON. Thus the SSB

crystal filter is selected. At the same time, R8V is applied to the base of Q6 through D13 and turns OFF Q6, thus F11 is isolated from the circuit.

When the optional CW crystal filter is installed and P2 is connected to J6, Q4 is turned ON and R8V is applied to D5 and D23, and D5 and D23 are turned ON. Thus the CW crystal filter is selected. At the same time, R8V is applied to the base of Q6 through D9 and turns OFF Q6, thus F11 is isolated from the circuit the same as when SSB crystal filter is installed.

D6 is turned ON when the optional CW filter is selected, and it shunts to ground the optional SSB filter input terminal to prevent signal leakage in the pass band of the SSB filter.

These optional filters are selected only when the set is in the receive mode.

3 - 1 - 3 MAIN UNIT

The receive signal from the 2nd IF unit P1 is fed to J16 on

the MAIN unit. In the receive mode, D1 is turned ON and D10 is turned OFF by the R8V, and the signal is fed to the 1st gate of IF amplifier Q1, dual gate MOS FET. To the 2nd gate, AGC voltage is applied. Its attack time is determined by R4 and C4.

The amplified 2nd IF signal is fed to the 1st gate of the 3rd mixer Q3, dual gate MOS FET through D2, which is turned ON in the receive mode. To the 2nd gate, 9.4665MHz local oscillator signal for IF TUNE or PBT is applied, and the 2nd IF signal is converted into 455kHz 3rd IF signal.

In SSB or CW mode, the 3rd IF signal is passed through F11 mechanical filter through D4 and D6, which are turned ON. MF-455-11AZ or MF-455-11GZ is employed for F11. 11AZ has 1.5kohm and 240pF input/output impedance and 11GZ has 1.5kohm and 20pF. Thus, C75 through C78 are not used for the 11GZ.

In AM mode, the 3rd IF signal is passed through F12 ceramic filter through D5 and D7.

The output from the 455kHz filters is fed to a balanced mixer consisting of Q4 and Q5, and converted into a 9.0115MHz 4th IF signal again. The local oscillator signal is the same one for the 3rd mixer, and fed to the center tap of the input tuned circuit. The 4th IF signal is fed to IF amplifier Q6 through a switching diode D8, then amplifier Q7. Both amplifiers employ dual gate MOS FET respectively. To the 1st gate, the IF signal is fed and to the 2nd gate, AGC voltage is applied respectively. The amplified signal is fed to the DET UNIT through J6, Pin 5.

The source voltage of Q8 is varied according to AGC voltage i.e., incoming signal level. This voltage is amplified by Q7, then fed to the S-meter. R42 is for meter zero-point adjustment and R41 is for full-scale adjustment.

3 - 1 - 4 IF TUNE AND PBT CIRCUITS

The VXO circuit consisting of Q11 and X1 oscillates at 9.4665MHz, and this frequency can be changed by ± 1.5 kHz by changing the voltage applied to D13 varactor diode. This voltage is varied by R13, PASS BAND SHIFT CONTROL on the front panel, and applied to D13 through D12 in the receive mode. In the transmit mode, a voltage adjusted by R66 is applied to D13 through D11, and the oscillation frequency is fixed at the center frequency, 9.4665MHz. This signal is fed to the 2nd gate of Q3, 3rd mixer, and 4th mixer Q4 and Q5 through a buffer amplifier Q12.

When the Pass-Band Shift Control is set at the center position, the VXO oscillates at 9.4665MHz, and 9.0115MHz, the center frequency of the 2nd IF signal is converted into 455kHz, the center frequency of 3rd IF signal. This 455kHz signal is converted into 9.0115MHz signal again with the 9.4665MHz VXO signal. This is the normal condition of the Pass-Band Shift system and incoming signals pass through both pass-bands of the filters, 9.0115MHz and 455kHz.

When the PB Shift Control is slid toward the right side, the VXO frequency is increased, as an example; 9.4675MHz

(9.4665MHz+1kHz), 9.0115MHz, the center frequency of the 2nd IF signal is converted into 456kHz, 3rd IF signal. This 456kHz signal is converted into 9.0115MHz signal again with the 9.4675MHz VXO signal. However, the 456kHz, 3rd IF signal is off from the center frequency of the 455kHz filter. In other words, the pass-band of the 455kHz filter is shifted toward the lower side, and the total pass-band is also shifted toward the lower side. At this time, if the optional SSB filter FL-30 is installed, the total band width is narrowed from the upper side. Thus the center position of the control is the widest bandwidth and is equivalent to the normal SSB bandwidth, and the bandwidth is narrowed electrically from either the upper or lower side continuously by up to 800Hz.

3 - 1 - 5 DETECTOR CIRCUITS

In the SSB and CW modes, a 9.0115MHz, 4th IF signal is fed to IC2, product detector in the DET unit. To the other port of IC2, a BFO signal is applied and an AF signal is put out from pin 3. The BFO is composed of Q8, X1, C39, C40, L2 through L4, etc. C39, C40 and L2 through L4 are connected in series with X1, and L2 through L4 are shunted to ground respectively according to the selected mode to get proper BFO frequency.

The detected AF signal is fed to pin 5 of IC1 operational amplifier. The amplified AF signal is put out from pin 7 and fed to Q7, low-pass filter, then to the VOLUME control on the front panel.

In the AM mode, the 4th IF signal is fed to Q1, IF amplifier. A part of the amplified signal is then fed to AM detector D5.

The detected AF signal is fed to pin 3 of IC1, operational amplifier. The amplified AF signal is put out from pin 1 and then fed to low-pass filter Q7.

As an AGC voltage, a part of the 4th IF signal at Q1 collector is fed to AGC detector D1. The detected DC signal is then fed to the base of Q2. When the applied voltage is over the threshold voltage, Q2 is turned ON and a negative voltage connected to the emitter, charges C6 through R9. When the applied voltage becomes less than threshold voltage, or zero, Q2 is turned OFF and the voltage of C6 is discharged through R8 (high value resistor). This provides fast attack/slow release AGC. AGC voltage is taken from the collector of Q2 and supplied to each 2nd gate of the IF amplifiers. On the AGC line, the RF gain control voltage from the RF GAIN control is superimposed.

When the AGC switch on the front panel is pushed in, Q10 is turned ON, and R13 and C10 (in series) are connected in parallel with R8 and the AGC time constant becomes shorter.

3 - 1 - 6 AF POWER AMPLIFIER CIRCUIT

AF signal from the VOLUME control, R8-2, on the front panel is fed to pin 1 of IC1 AF power amplifier on the MAIN unit. The signal is amplified with IC1 to get 2 watts output power in an 8 ohm load. The output signal is fed to the internal speaker through the PHONES jack and EXTERNAL SPEAKER jack. This IC is activated in the transmit mode to produce the CW side-tone.

3 - 2 TRANSMITTING CIRCUITS

3 - 2 - 1 AF CIRCUITS

The audio signal from the microphone is fed to pin 3 of IC4, operational amplifier on the MAIN unit, through the MIC GAIN control R14-2 on the front panel. The amplified AF signal is put out from pin 1, then fed to pin 5 of the balanced modulator, IC2 in the DET unit, which is the same one for the receiver product detector. To pin 7, the BFO signal is fed and mixed with the audio signal, and a 9.013MHz or 9.010MHz modulated DSB (carrier suppressed double side band) signal is put out from pin 3.

In the receive mode and SSB transmit mode, bias voltages adjusted by R44 and R45 are applied to pins 5 and 7 respectively to place IC2 in a carrier null condition. In the AM and CW transmit modes, Q6 is turned OFF and an offset voltage is applied to pin 5 through D4. Thus IC2 is in an unbalanced condition and a 9.0115MHz AM signal or carrier is put out from pin 3. In the other modes, Q6 is turned ON and the offset voltage is shunted to the ground and IC2 is in a balanced condition.

In the receive mode and CW transmit mode, Q5 is turned ON and shunts the AF signal from the microphone to ground to prevent the AF signal is applied to IC2.

3 - 2 - 2 IF CIRCUITS

The signal output from IC2 in the DET unit is fed to the 1st gate of Q3, mixer, the same one for receive 3rd mixer, through D3 in the MAIN unit to be converted into a 455kHz signal. The local oscillator for this mixer is also the same one for the receive. However, the oscillation frequency is fixed at 9.4665MHz.

In the receive mode, Q2 is turned ON and shunts the signal fed from the DET unit to ground to prevent the signal from leaking into the receiver IF circuits.

In the SSB and CW modes, the 455kHz signal is fed to FI1, MF-455-11GZ (or -11AZ), mechanical filter which has a 2.4kHz bandwidth, to remove unwanted sideband signal.

In the AM mode, the 455kHz AM signal is fed to FI2, CWF455HT, ceramic filter which has a 6kHz bandwidth, and the signal passes through the filter unchanged.

The output from the selected filter is then fed to the balanced mixer consisting of Q4 and Q5 which is the same one used in the receiver's 4th mixer. The mixer's purpose is to convert the incoming signal to 9.0115MHz. The 9.0115 MHz signal is then fed to the IF amplifier Q9.

In the CW mode and key-up condition, a positive voltage is applied to the source of Q9 through D19, and Q9 is turned off and the signal is not fed to the next stages. In key-down condition, Q10 is turned ON and the positive voltage applied to the source is shunted to ground through Q10. Thus the positive voltage is not applied, Q9 functions in normal condition and the signal is amplified then fed to the next stages.

The amplified IF signal is then fed to FI1, 9M10A 9.0115

MHz crystal filter (or installed optional crystal filter) in the 2ND IF unit.

Then the signal is fed to the doubly balanced mixer consisting of D1 through D4, which is the same one used in the receiver's 2nd mixer. In this case, the mixer's purpose is to convert the incoming signal to 39.7315MHz.

The 39.7315MHz signal is fed to the amplifier Q7, then the mixer consisting of D4 through D7, which is the same one for receiver 1st mixer, for conversion to the desired operating frequency.

When 10MHz, 18MHz or 24.5MHz band is selected, a positive voltage is applied to the source of Q7 through D27, D26 or D25 respectively. This turns Q7 OFF and mutes transmission on these bands. To transmit on these bands, cut lead of the diode for the desired band.

The desired operating frequency signal is fed to the band-pass filter to produce a clean output. The appropriate filter is selected with the BAND switch. The signal is then amplified by Q4 and fed to the PA unit.

3 - 2 - 3 RF POWER AMPLIFIER CIRCUITS

The transmit signal fed to the PA unit is amplified by Q1 up to about 1 watt. Q1 is a class A amplifier and maintains high linearity.

L2 gives the correct phase signals (180 degrees apart) for the push-pull amplifier Q2 and Q3. Q2 and Q3 are class AB amplifiers and amplify the signals up to about 6 watts. The bases of Q2 and Q3 are biased by means of the barrier voltage set by D1. D1 functions as temperature compensator for Q2 and Q3, and is attached to the case of Q2. Negative feedback by R and C applied across each collector and base of Q2 and Q3, provides stability and broadband characteristics.

L4, a broadband transformer provides balanced DC feed to the collectors of Q2 and Q3, and for matching the collector-to-collector impedance.

Then the signal is fed to each base of Q4 and Q5 through L4 secondary for impedance matching and correct phasing. Q4 and Q5 are class AB push-pull amplifiers which produce 100 watts output.

The bases of Q4 and Q5 are biased for class AB operation by the emitter voltage of Q6 which is controlled by the barrier voltage of D2. D2 voltage is adjusted by R21 to give proper idling current.

D2 also functions as a temperature compensator to prevent runaway caused by heating, and is attached to the case of Q4.

R17 and R18 are resistors which provide negative feedback from L7. L7 samples the output and provides stability and broadband characteristics.

The signal amplified by Q4 and Q5 is fed to the FIL (low-pass filter) unit through L8 impedance matching transformer.

A thermal switch is mounted on the case of Q4 and turns ON when the case temperature exceeds 70 degrees C. This changes the speed of the cooling fan from low to high. This cooling fan rotates at low speed during transmit in the normal condition. At this time, 8 volts is supplied to the fan motor through R22, R23 and Q7. When the thermal switch is turned ON, 13.8 volts is supplied to the fan motor through R22 only, and the cooling fan rotates at high speed not only in the transmit mode but also in the receive mode.

The transmit signal which has passed the low-pass filter is fed to the ANT (antenna) connector on the rear panel through the SWR detector coil L15 in the FIL unit.

3 - 2 - 4 ALC CIRCUITS

The forward power voltage, SWF and reflected power voltage, SWB, detected at the FIL unit, are fed to the MAIN unit through J20. The forward power voltage, SWF, is fed to the negative input terminal of IC2B and amplified as an ALC voltage. This ALC voltage is fed to the 2nd gates of Q9 in the MAIN unit and Q7 in the RF unit.

In the SSB or CW mode, the attack time of the ALC voltage is determined by R70, C43 and R169 and the release time is determined by C43 and R88, and a peak voltage is put out.

In the AM mode, Q13 and Q14 are turned ON, and the attack time is determined by R70 and C42, and the release time by R68 and C42, and an average voltage is put out.

To the positive terminal of IC2B, a voltage from the RF POWER control on the front panel is applied to control the ALC voltage and the output power can be adjusted between 10 watts and 100 watts by adjusting the RF POWER control.

The ALC voltage is also fed to the negative terminal of IC3B through R88 and amplified to indicate ALC level on the meter. The swing of the meter is adjusted by R91.

The voltage applied to the negative terminal of IC2B is controlled by the RF POWER control on the front panel.

When the control is turned fully counterclockwise, the voltage is minimum and the output power is also minimum (10 watts). This voltage (output power) can be adjusted by R149.

When the control is turned fully clockwise, the voltage is the maximum and the output power is also the maximum (SSB and CW: 100 watts, AM:40 watts). This voltage is divided from 8 volts by R147 and R150, and can be adjusted by R150.

In the AM mode, Q19 is turned ON and R151 is connected with R150 in parallel, and the maximum power is reduced to 40 watts.

S3 is a switch to reduce the maximum power to 50 watts. When S3 is switched ON, a voltage is applied to the base of Q19 through D28 and R153 and Q19 is turned ON the same as in the AM mode. In addition, a voltage is applied to the RF POWER control through R168 and D29, and the maximum power is adjusted to 50 watts by R168. In the AM mode, Q20 is turned ON and R168 is shunted to ground and the maximum power is 40 watts as usual.

3 - 2 - 5 VOX CIRCUITS

Audio signal from the microphone is fed to pin 5 (positive input terminal) of IC6, comparator, through J3 and R137, VOX GAIN control. To pin 5, a bias voltage which is divided by R132 and R135, and R136 is applied through R137. To pin 6 (negative input terminal), a reference voltage which is divided by R132, and R135 and R136 is applied. The difference voltage between the two terminals is only the voltage across R135. Thus the sensitivity of the comparator is very high and the VOX circuit actuates with a small input level. When a voice signal presents, the output terminal (pin 7) of IC6B becomes at High level and this voltage charges C63. The charged voltage is discharged through R128 and R129 and it decides the VOX holding time. The VOX holding time can be adjusted by R129. This High level voltage is applied to pin 5 (positive input terminal) of IC5B, VOX control.

In the CW mode, IC5A is used as a break-in control.

In the key-up condition, the same bias voltage is applied to both pin 2 (negative input terminal) and pin 3 (positive input terminal), and pin 1 (output terminal) is low level. In the key-down condition, pin 2 is grounded through R117 and pin 1 becomes at high level. This voltage charges C62 and is applied to pin 5 of IC5B. The holding time is decided by C62, and R128 and R129.

To pin 6 of IC5B, a bias voltage divided by R125 and R139 is applied as a reference voltage. When the voltage at pin 5 becomes higher than that one at pin 6, pin 7 (output terminal) puts out high level voltage. This turns on Q17 and Q18, and grounds the SEND line, when the VOX switch is turned on, to set the radio in the transmit mode.

3 - 2 - 6 ANTI VOX CIRCUITS

A part of the receiver audio signal put out from IC1 is fed to pin 3 (positive input terminal) of IC6A, comparator, through the ANTI VOX level control, R142. When a receiver audio is present, pin 1 of IC6A puts out high level voltage. This voltage is applied to pin 6 of IC5B, and increases the reference voltage and cuts off IC5B. Thus the VOX circuit does not function with an audio from the speaker.

3 - 3 1ST LOCAL OSCILLATOR CIRCUITS

The 1st local oscillator employs a premix system consisting of a PLL and a crystal oscillator for each band.

1. PLL (PHASE LOCKED LOOP) CIRCUITS

The PLL employs a mixed down type, and is locked in 10kHz steps. This output is divided into 1/10, as a result, 1kHz steps is obtained.

The local oscillator, Q1 oscillates at 13.666MHz with the crystal unit X2. This signal is tripled at Q2 and Q3, thus the local oscillator output, 123MHz is obtained. A varactor diode, D1 is connected in series with X2, and voltages from the RIT control and FREQUENCY SET control are applied to the cathode and anode respectively. This varies the local oscillator frequency slightly to provide the RIT function and frequency calibration.

Q6 is the VCO (Voltage Controlled Oscillator), and oscillates at a frequency between 132MHz and 139MHz. The

output signal is fed to the base of Q4, PLL mixer, through buffer amplifiers Q7 and Q8. To the emitter of Q4, the local oscillator signal is fed and mixed with the VCO signal to mix down the VCO frequency.

The output signal from the mixer is fed to the low-pass filter consisting of C23, L6 and C24, to filter out only the signal below 15MHz. Then the signal is amplified to the proper level (more than 3V P-P) of the programmable divider, IC1, by Q5.

IC1, PLL IC, consists of the programmable divider, reference frequency oscillator, fixed divider, phase detector, etc. The reference frequency oscillator oscillates at 9.000 MHz, and its signal is divided into 10kHz and fed to the phase detector as the reference frequency.

The signal from Q5 is divided into 1/N at the programmable divider. The N data is sent from the CPU in the LOGIC unit in sequence as shown in the illustration.

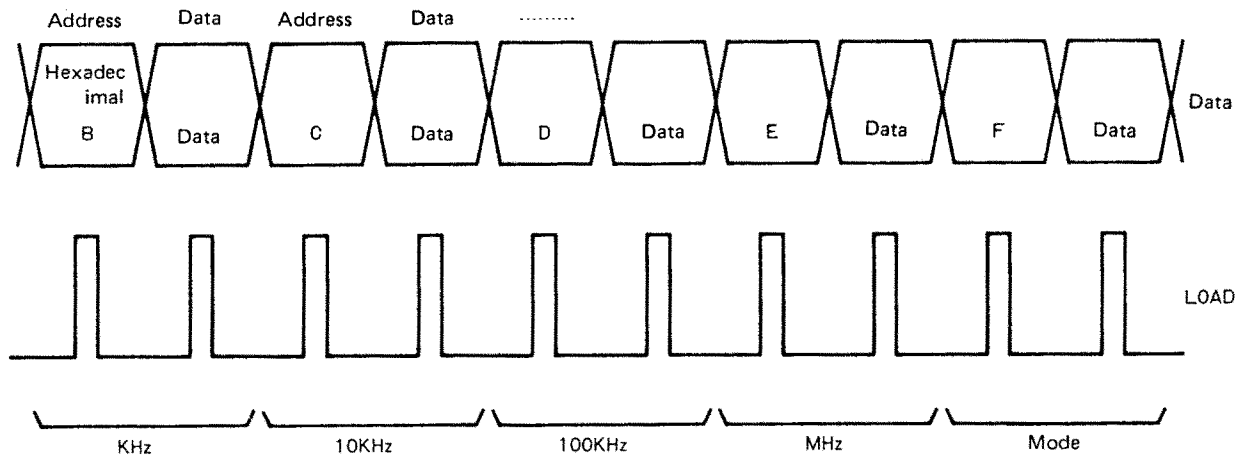

The divided signal is fed to the phase detector internally. The phase detector detects the phase difference between the 10kHz reference signal and the output signal from the programmable divider, and proportionately puts out positive/negative pulse signal at pin 14.

This pulse signal is fed to the loop filter consisting of R28 through R30 and C34 through C36, then fed to the varactor diode, D2, to lock the VCO frequency.

The locked VCO signal is fed to the buffer amplifier, Q7, and a part of this signal is fed to the 1/10 divider, IC2. Then the divided signal, between 13.2MHz and 13.9MHz with 1kHz steps, is fed to the mixer in the PREMIX unit through low-pass filter consisting of C53 through C57, L10 and L11, and attenuator consisting of R41 through R43.

2. PREMIX CIRCUITS

The premix circuits are composed of offset frequency oscillator for each band, mixer and band-pass filter for each band.

Q1 through Q11 are offset frequency oscillators. One of them is selected by the band signal from the band switch

and oscillates at the frequency shown in the table for each band.

BAND	OFFSET FREQUENCY
3.5	29.9315MHz
7.0	33.4315MHz
10.0	36.4315MHz
14.0	40.4315MHz
18.0	44.4315MHz
21.0	47.4315MHz
24.0	50.9315MHz
28.0	54.4315MHz
28.5	54.9315MHz
29.0	55.4315MHz
29.5	55.9315MHz

The offset frequency signal is fed to the doubly balanced mixer consisting of D1 through D4, and L12 and L13. To the other port of the mixer, the PLL output signal is applied to convert into the 1st local oscillator signal.

D12 through D33 are matrix diodes to convert the band signal into hexadecimal code for the CPU.

The output signal from the mixer is then fed to the BPF unit. The BPF unit is composed of a high-pass filter, low-pass filter and band-pass filter for each band, and buffer amplifiers.

The high-pass filter is composed of C1 through C5, and L1 and L2.

The low-pass filter is composed of C6 through C13 and L3 through L5.

The band-pass filters are provided for each band and selected one of them by the band signal from the band switch.

The signal passed through the high-pass filter, low-pass filter and a band-pass filter is then fed to the buffer amplifiers, Q1, Q2 and Q3. The output of Q3 is then fed to the mixer consisting of D4 through D7 in the RF unit as the 1st local oscillator signal.

3. LOGIC CIRCUITS

The logic circuits control operating frequency, band, mode, PLL, display etc., and are designed for low power consumption and high speed operation using a CMOS 4-bit CPU.

The CPU, IC1 is a plastic package with 42 pins. CL0 and CL1 of pins 1 and 42 are the clock terminals for this CPU, oscillating at about 400kHz with X1 ceramic oscillation unit.

The CPU has a total of 9 input and output ports, each sharing its own function:

Port A - 4 bit input

Decodes the port E output as shown in the matrix table to expand input functions with time sharing.

Port B - 4 bit input

Used as an input port for the sensor (tuning control).

Port C - 4 bit output

Outputs the 2nd local oscillator 100Hz steps D/A converting signal.

Port D - 4 bit output

Outputs the 2nd local oscillator 10Hz steps D/A converting signal.

Port E - 4 bit output

Outputs various data as a general purpose output terminals.

Port F - 3 bit output

- F0 : Strobe signal output for display.
- F1 : Load signal output for PLL above 1kHz digit.
- F2 : Reset signal output for display.

Ports G and H are not used.

Port I - 1 bit output

I0 : Reset signal output for sensor counter.

When the power switch is turned on, 13.8V DC is applied to IC9, voltage regulator, through R2 and D1. IC9 puts out regulated 5V. At the same time, Q2 is turned on and supplies the regulated 5V as the power source of the LOGIC unit. When a memory backup power source is connected, the power is applied to IC9 through R1, and regulated 5V is supplied to IC1, the CPU to maintain the operating frequency, memorized frequency, etc. At this time, Q2 is turned off and 5V is not supplied for the other circuits.

At the moment of the power switch has been turned on, a pulse is fed to pin 3 of IC8 through C3. After the pulse has been waveform-shaped, it is fed to the reset terminal (pin 7) of IC1, to initialize the CPU.

The matrix circuit is designed as follow:

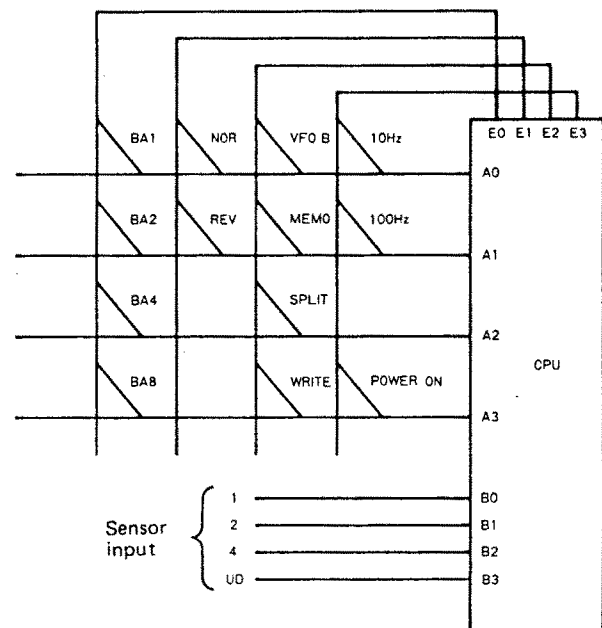

BA1 through BA8 are band data which is fed from the PREMIX unit.

This data is processed by the CPU and the CPU puts out signals to control the display and PLL.

In the SSB operation, the selected sideband (LSB or USB) is reversed automatically when changing the operating band from 10MHz to the lower band or from 7MHz to the upper band. For this function, the band data and mode data (LSB or USB) from the mode switch are fed to exclusive OR gates, IC7, and their outputs are fed to A0 and A1 input terminals of the CPU.

The two signals from the rotary encoder connected to the tuning control are input to SENS1 and SENS2 terminals of the LOGIC unit, and waveform-shaped by the respective Schmitt triggers, consisting of IC2 and R11 through R14. One of the waveform-shaped signal is fed to pin5 of IC7,

inverter, then Pin6 of IC3 as a switching signal. The other waveform-shaped signal is output from pin3 of IC2 and differentiated by C12 and R10, then fed to pin1 of IC3, inverter. The output signal from pin3 of IC3 is also differentiated by C11 and R9, then fed to pins 5 and 12 of IC3. To the other gates of IC3, the switching signal is applied and controlled the differentiated signals. The output signals from pins 4 and 11 of IC3 are fed to 2-input NOR gate of IC3 and combined as the UP signal. This UP signal is fed to CP terminal of IC5, flip-flop, and it holds the output terminal, pin 13, H-level when the UP signal is present. This H-level signal is then fed to B3 terminal of the CPU, and the CPU processes to increase the operating frequency. When the tuning control is turned counterclockwise, the B3 terminal is maintained in the L-level.

Two differentiated signals at C12 and C11 are fed to pins 5 and 6 of IC2, OR gate, and combined signal is output from pin4. The rotary encoder outputs 50 pulses per revolution, while pin4 of IC2 outputs both leading edge and trailing edge, resulting in an output of 100 pulses per revolution. This output signal is fed to a counter of 3-bit, consisting of IC4 and a half of IC5.

This counter is capable of counting a maximum of 7 pulses, and serves as a timing buffer between the encoder and the display in relation to reading by the CPU. If there is any output at the counter, the output of the diode OR gate, consisting of D5 through D7, becomes H-level, input to inverter, IC8, then input to the INT terminal of the CPU with its level inverted to L-level. This terminal is a priority terminal which gives priority to sensor processing by stopping other operations. In the priority routine, counter data and up-down data fed to B0 through B3 terminals are read by the CPU, performing in this way all operations related to sensor processing.

Immediately after the sensor data have been read, a reset pulse is put out from I0 terminal, and the pulse is differentiated by C5 and R46, then fed to clear terminals of the counter and up-down latch to clear them.

The up-down control circuit consisting of Q3, Q4, R16 through R21, C17 through C21, etc., provides frequency control from the up-down switches on the microphone. When the UP or DOWN button is depressed, the multi-vibrator, Q3, oscillates and pulses are fed to pin6 of IC4, and the 3-bit counter counts the pulses the same as the pulses from the rotary encoder.

After processing, the CPU outputs frequency data for the PLL from the port E. This data is a 4-bit parallel data and it is output in sequence according to its digits. The port E also output frequency data for the display with time sharing. This data is 4-bit parallel and 8-digit data. F0 and F2 terminals output clock pulses for the display and F1 terminal outputs clock pulse for the PLL. Data for 1kHz and lower digits are output from the ports C and D, and fed to D/A converter consisting of R35 through R43 to convert into an analog signal. This analog signal is fed to the 2nd

local oscillator in the 2nd IF unit to get 10Hz step frequency resolution.

3 - 4 DISPLAY UNIT

This unit is composed of DS1 display tube, IC1 driver IC and DC-DC converter for the display tube and negative voltage source.

The frequency data is fed to pins 2 through 5, input port S, and timing control pulse is fed to pin 15. After processing, segment data is put out from pins 16 through 22 with digit control signal put out from pins 6 through 11. These signals are fed to the display tube and light the tube with dynamic lighting.

The DC-DC converter is composed of Q1, L1, R1 through R3, C1 through C4, D1 through D4, etc. This converter generates a negative voltage and filament voltage for the display tube, and -5V for the AGC circuit and operational amplifiers.

SECTION 4 INSIDE VIEWS

4-1 TOP VIEW

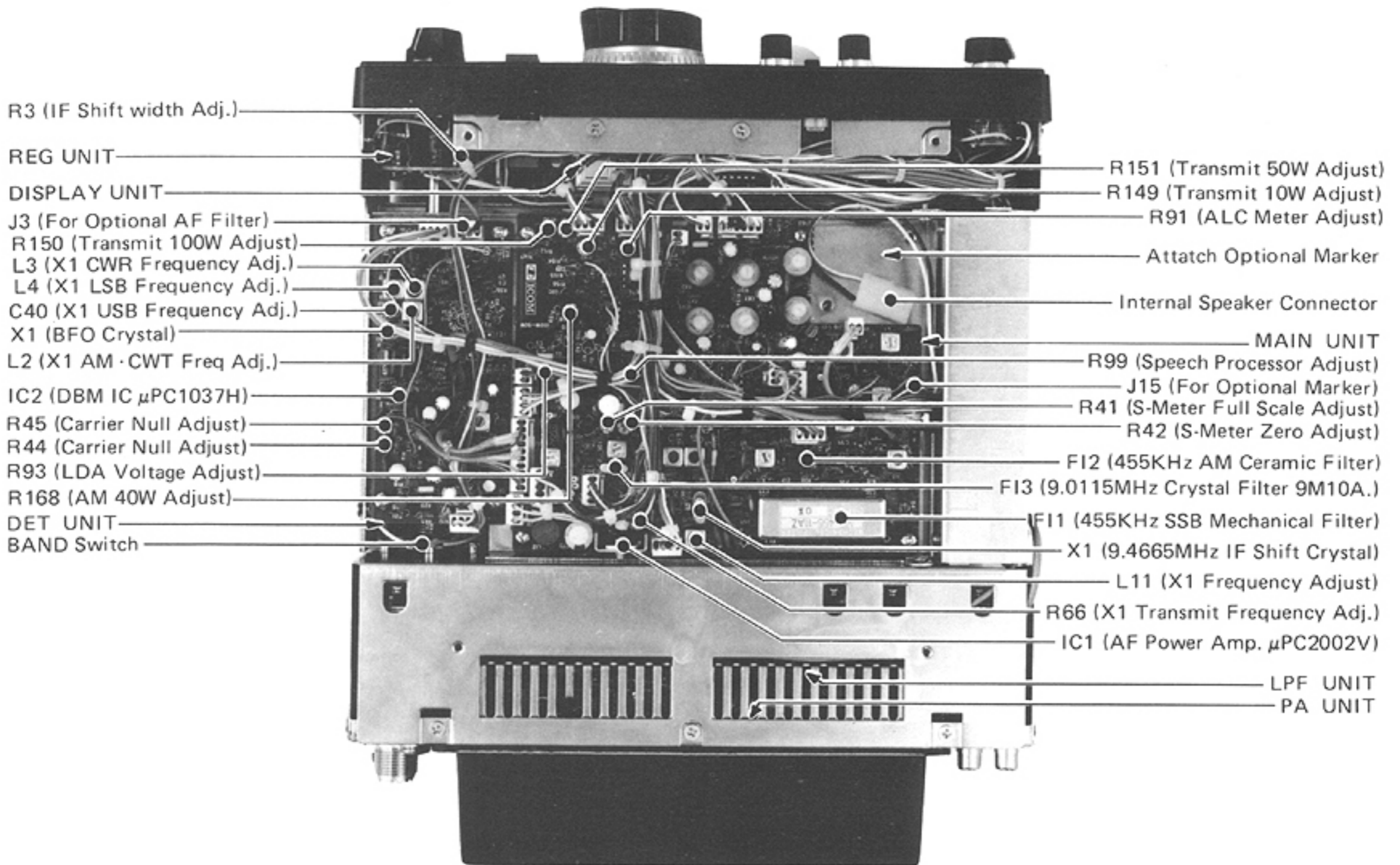

4-2 RF UNIT

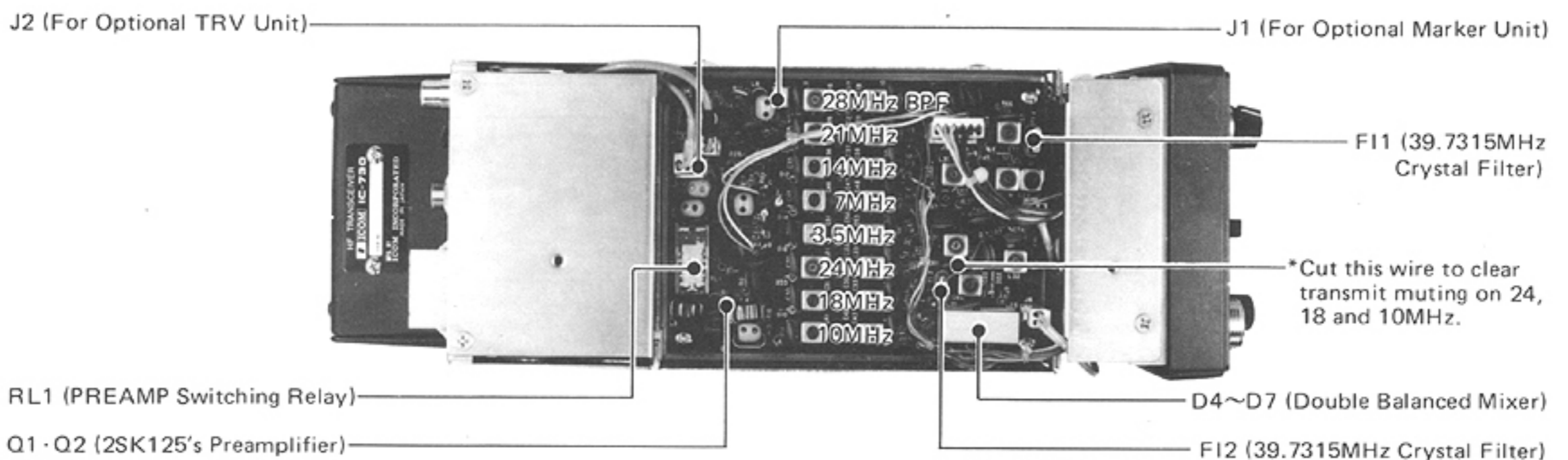

4-3 BOTTOM VIEW

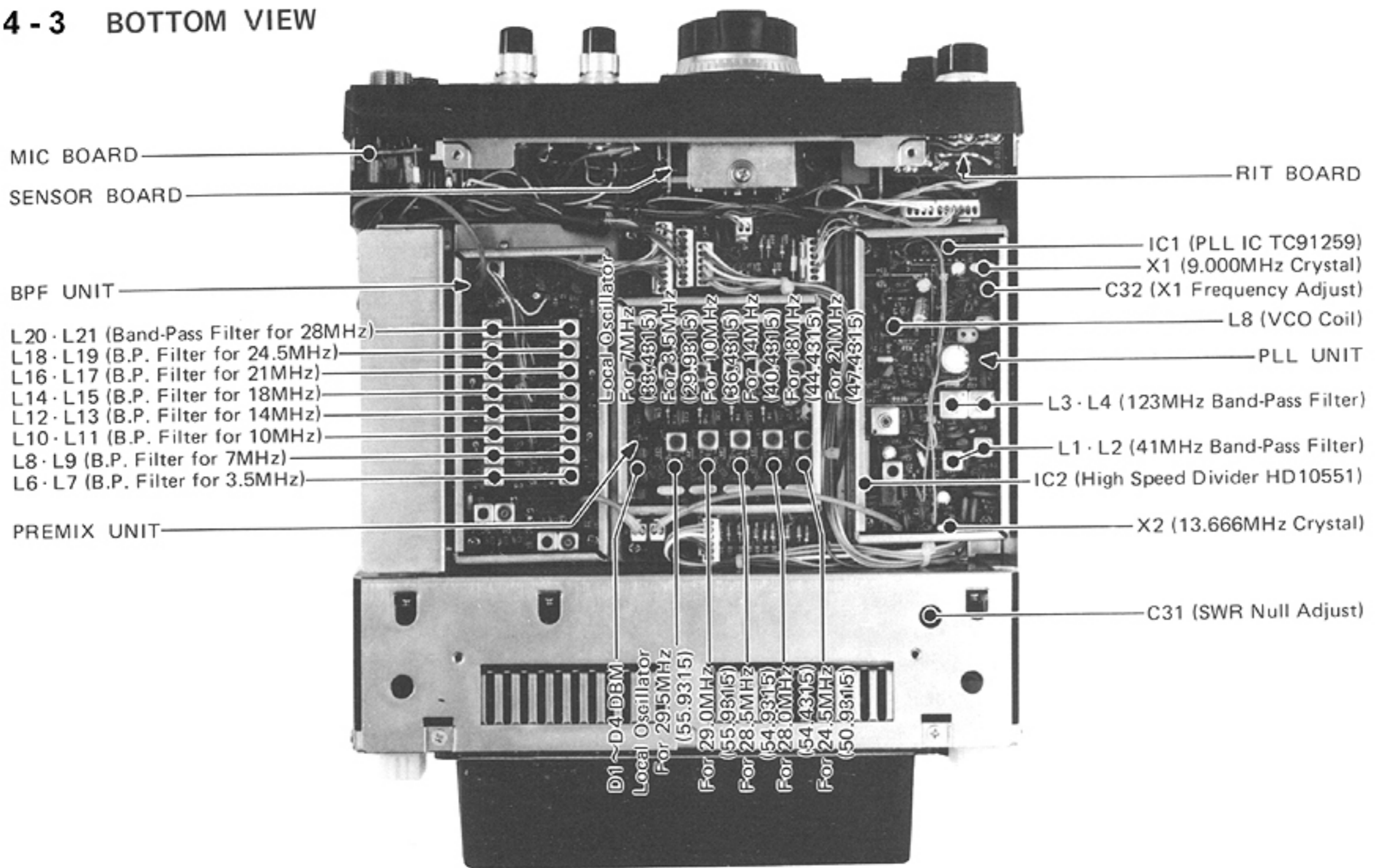

4-4 LPF UNIT and ACC BOARD

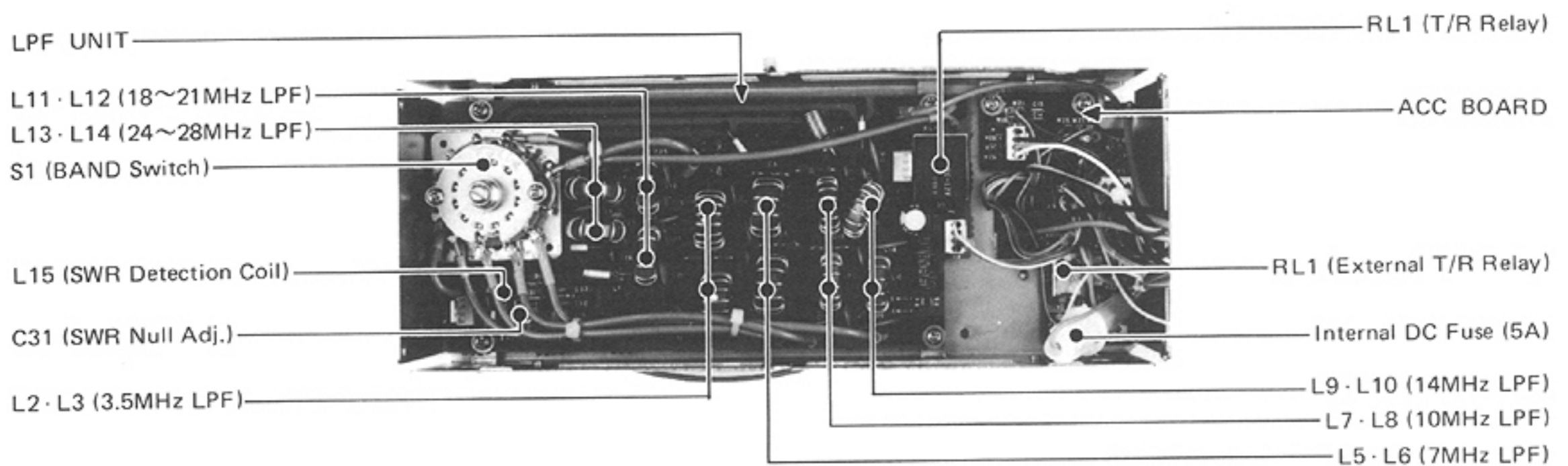

4-5 PA UNIT

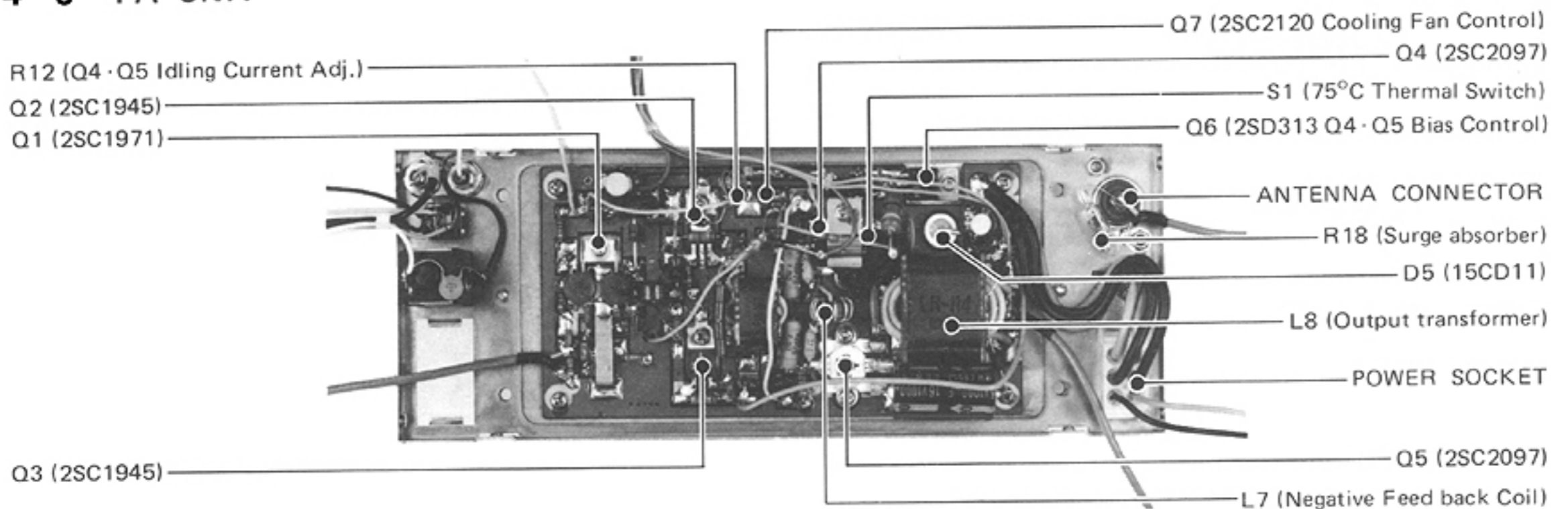

4 - 6 2nd IF UNIT

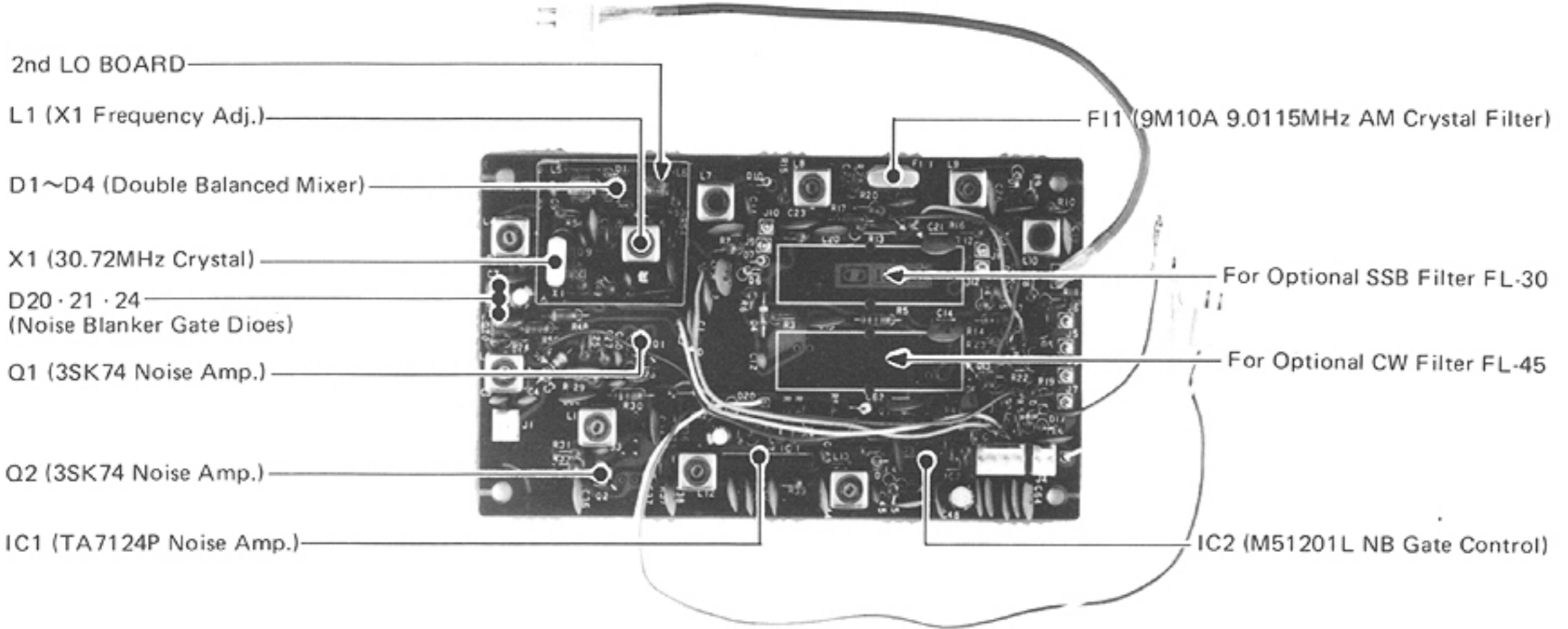

4 - 7 LOGIC UNIT

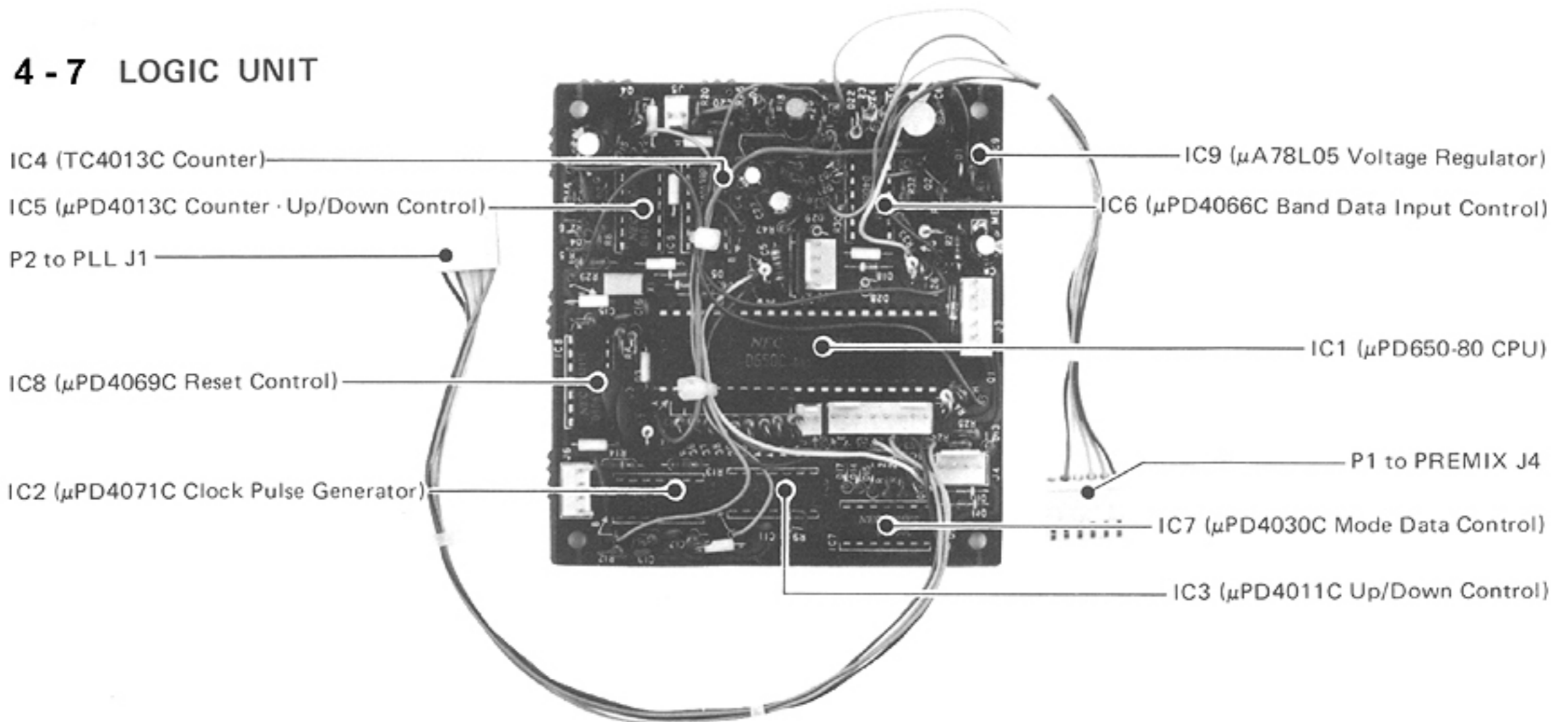

4 - 8 DISPLAY UNIT

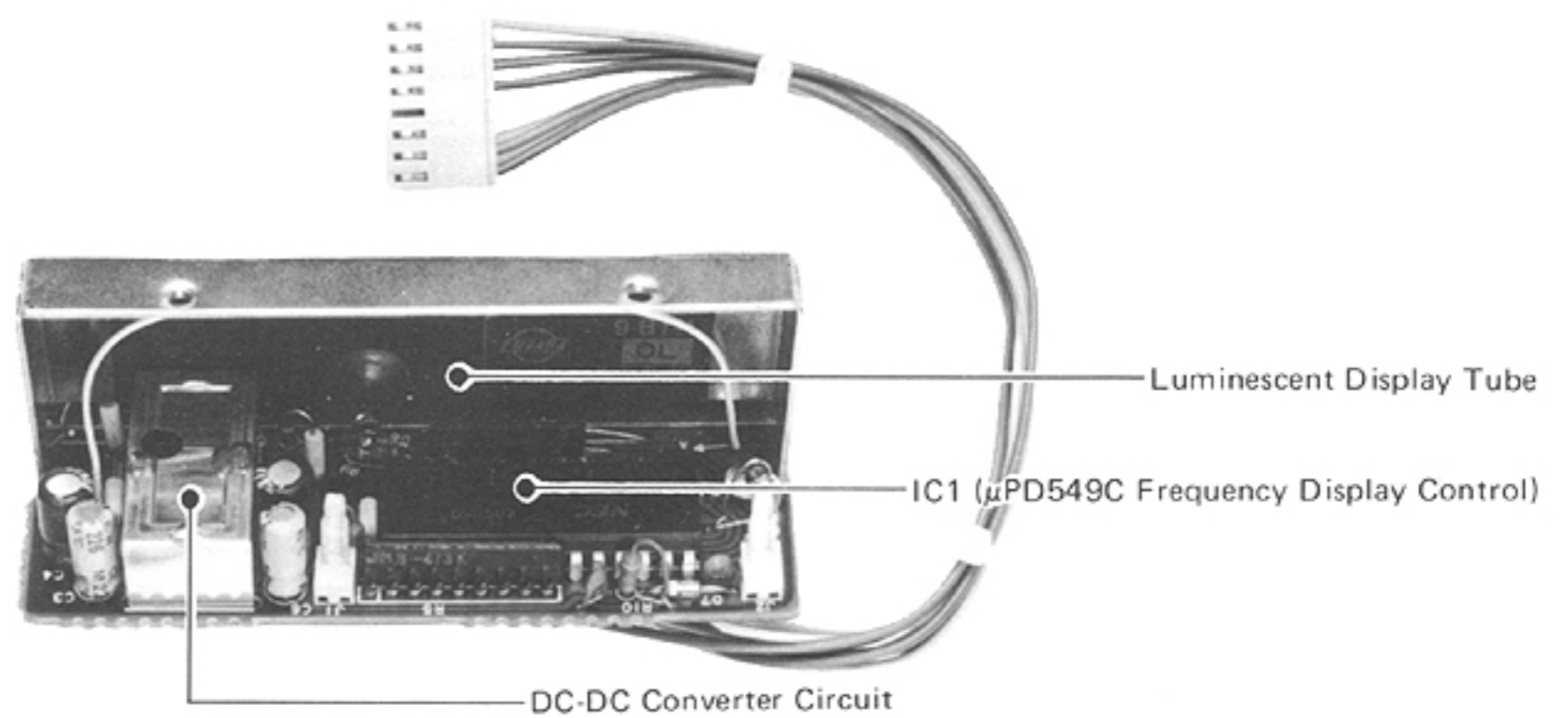

SECTION 5 BLOCK DIAGRAM

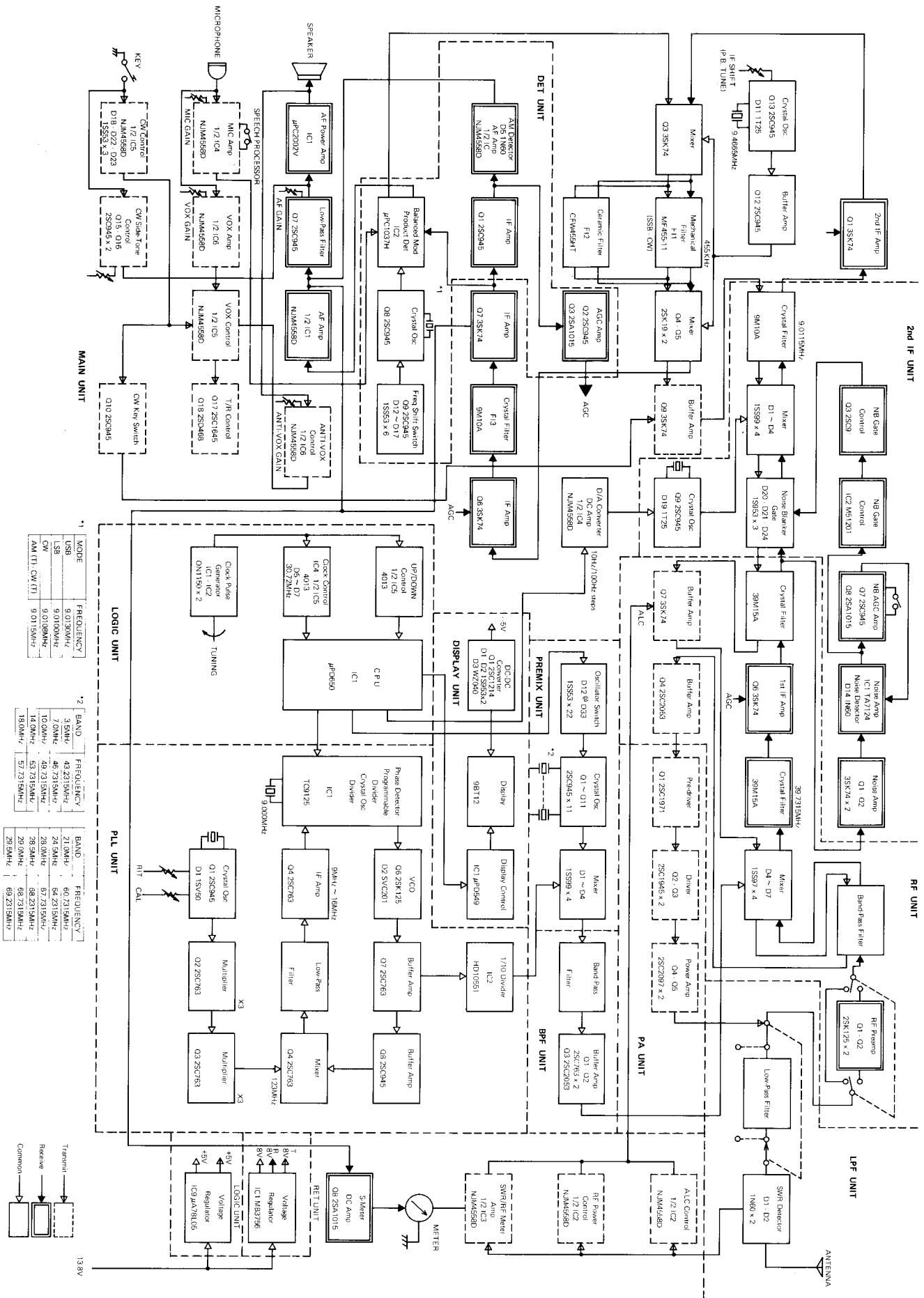

SECTION 6 OPTIONS INSTALLATION

6 - 1 DESCRIPTION

6 - 1 - 1 IC-EX195 (MARKER UNIT)

This unit generates marker signals to calibrate IC-730's operation frequency. The marker generator puts out accurate 100KHz or 25KHz signals on the entire band, and gives easy and accurate frequency calibration.

6 - 1 - 2 IC-EX203 (CW AUDIO FILTER UNIT)

This unit is an audio filter which gives 150Hz/6 dB pass-band in the CW operation. This is very effective in reducing interference from near-by signals and increasing SN ratio.

6 - 1 - 3 IC-EX202 (LDA UNIT)

This unit puts out the band control voltage to change operating band automatically for external equipment such as a linear amplifier and an antenna tuner.

6 - 1 - 4 IC-EX205 (TRV UNIT)

This unit provides terminals to put out a low level RF

signals, and for receiver input and T/R control on the rear panel of IC-730 for a VHF/UHF transverter.

6 - 1 - 5 FL-44(A) (455KHz SSB CRYSTAL FILTER)

This filter is for replacement of the 455KHz mechanical filter installed in the 2nd IF circuit, and has a higher shape factor and provides more selectivity.

6 - 1 - 6 FL-30 (SSB PASS BAND TUNING CRYSTAL FILTER)

This filter provides the Pass Band Tuning system which narrows the IF Pass Band continuously up to 1KHz either from upper side or lower side. This is very effective in reducing interference from nearby signals.

6 - 1 - 7 FL-45 (CW NARROW CRYSTAL FILTER)

This filter provides a 500Hz/6 dB pass band in the CW operation. When the MODE Switch of IC-730 is set in the "CW-N" position, this filter is selected automatically.

6 - 2 PREPARATION

6 - 2 - 1 TOOLS FOR INSTALLATION

The following tools are needed for the installation of the options.

Tools	IC-EX195	IC-EX203	IC-EX202	IC-EX205	FL-44(A)	FL-30	FL-45
Philips Screwdriver	○	○	○	○	○	○	○
Screwdriver for 2mm Hex-hole Screw	X	○	○	X	X	X	X
Soldering Iron (20W ~ 40W)	X	X	X	X	○	○	○
Solder (rosin core)	X	X	X	X	○	○	○
De-soldering Braid	X	X	X	X	○	X	X
Diagonal Cutter	X	X	X	X	○	○	○
Long-nose Pliers	X	X	X	X	○	○	○

NOTE: ○ means NEEDED, X means NOT NEEDED

6 - 2 - 2 PREPARATION

Before performing any work on the set, make sure that power cord is unplugged from the transceiver.

Remove the top cover by unscrewing the four screws on the top and the two screws at each side, while taking care not to damage the internal speaker and unplug its connector.

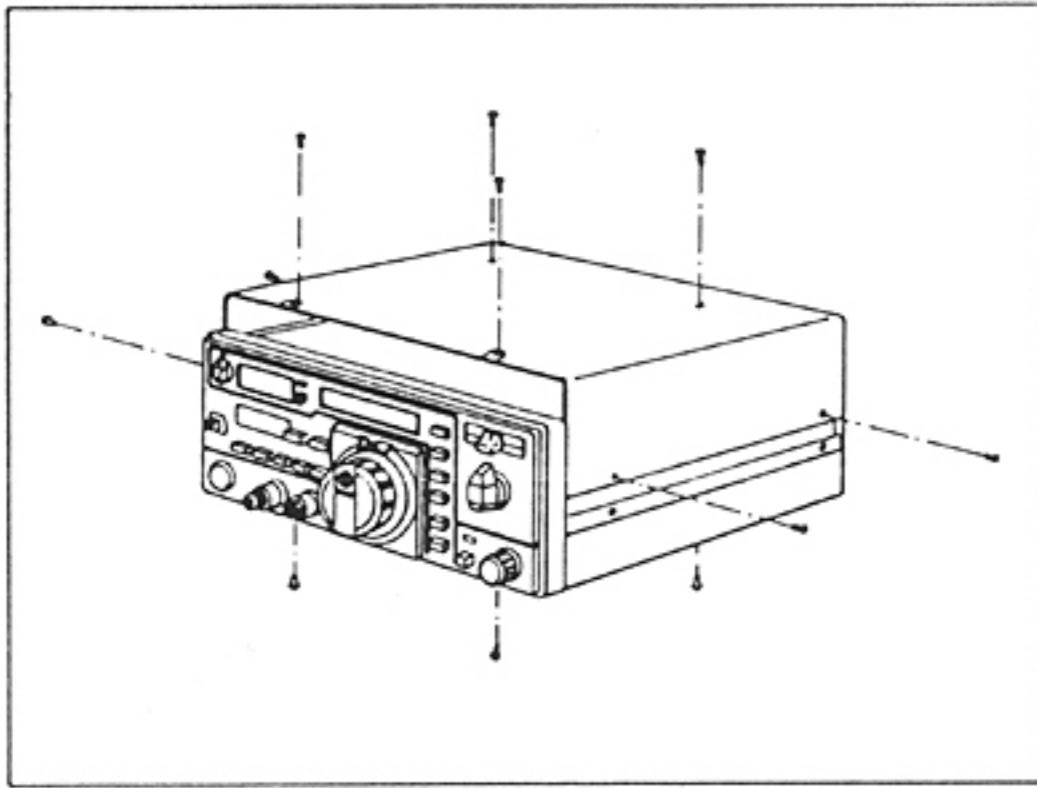

When installing IC-EX202 and/or IC-EX205, also remove the bottom cover by unscrewing the four screws on the bottom.

6 - 3 ASSEMBLY PROCEDURE

6 - 3 - 1 INSTALLATION OF THE IC-EX195 (MARKER UNIT)

1. PARTS LOCATION

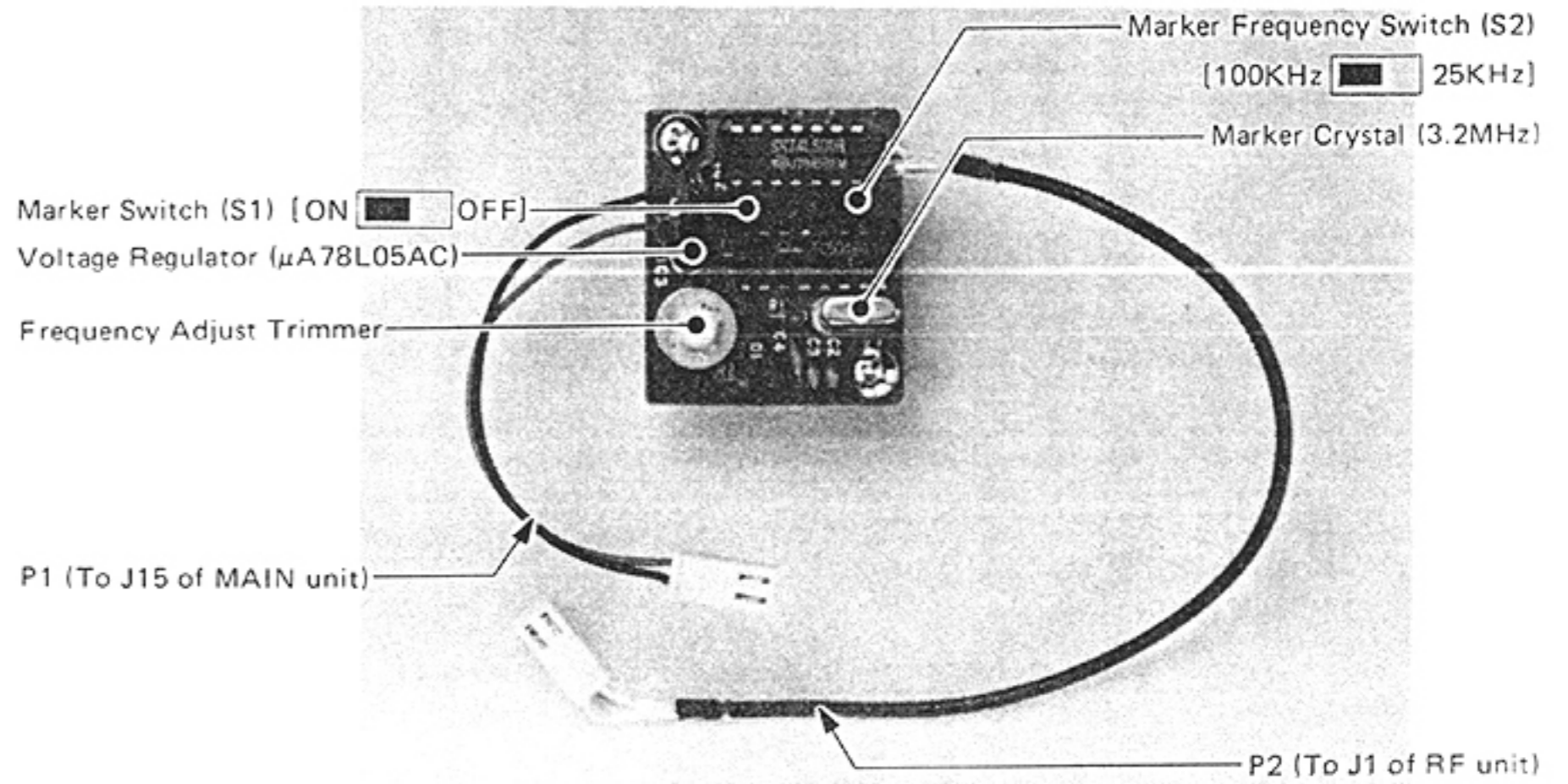

(2) Plug P1 of this unit to J15 of the MAIN unit.

2. ASSEMBLY PROCEDURE

(1) Install this unit in the position shown in the photo using the attached screws.

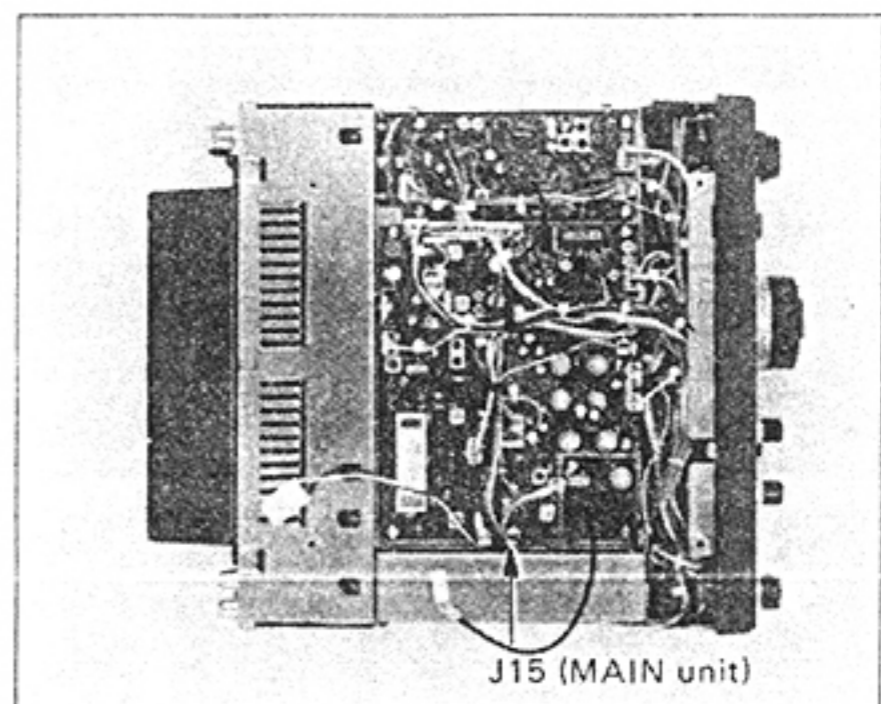
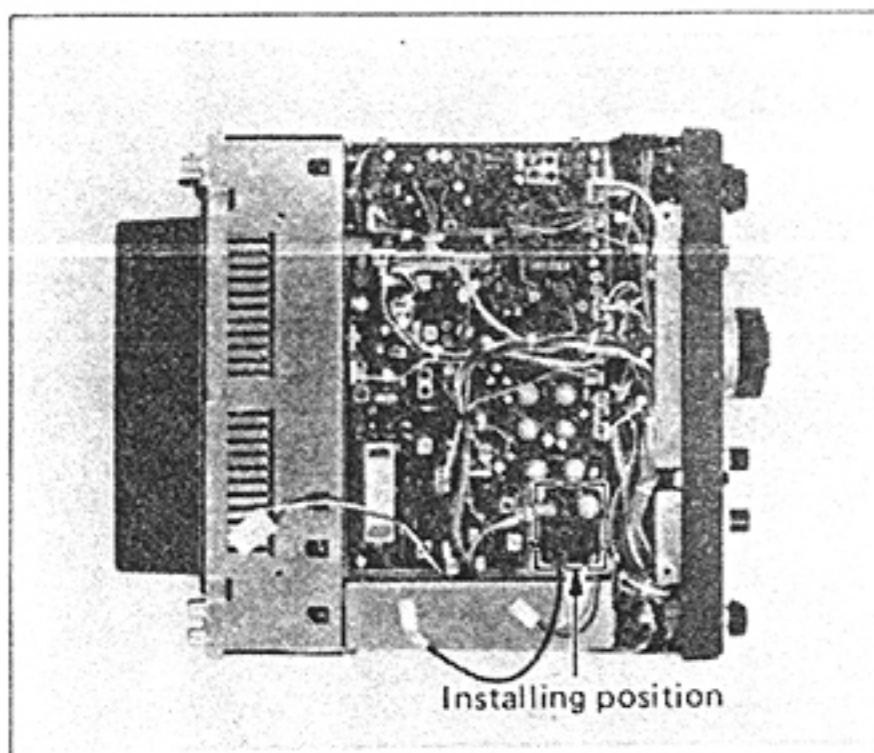

(3) Plug P2 of this unit to J1 of the RF unit.

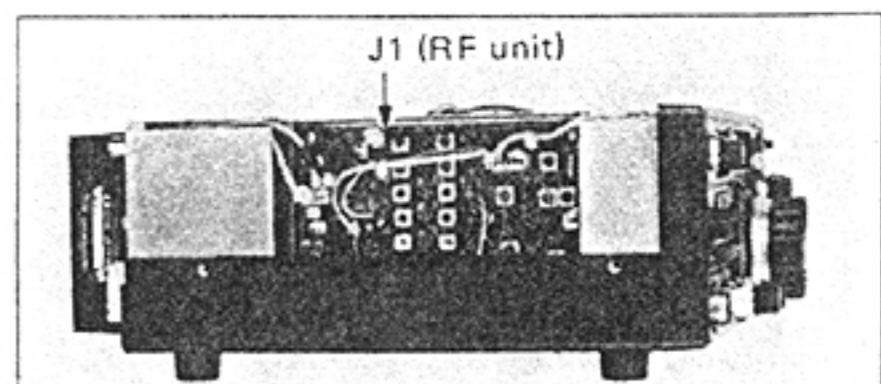

3. CHECKING THE OPERATION

- (1) While performing the installation, set the marker switch of the unit to the "OFF" position and the marker frequency switch in the "100KHz" position.
- (2) Connect the plug of the internal speaker on the top cover to the original connector, or an external speaker to the external speaker jack on the rear panel.
- (3) Make sure the power switch of your IC-730 is turned OFF. Set the other controls and switches in the receive mode according to the manual of IC-730. Then connect the power plug to the power socket of the IC-730.
- (4) Turn the power switch of the IC-730 ON, and the set operates in the receive mode.
- (5) Set the marker switch of this unit to the "ON" position and the marker frequency switch in the "100KHz" position. Then turn the tuning control knob, and you can receive a strong signal on every 100KHz.
- (6) Set the marker frequency switch in the "25KHz" position, and you can also receive a strong signal on every 25KHz. These are the complete operations of the unit.
- (7) When the operations are performed, unplug the power cord again and replace the speaker connector and covers.

4. CALIBRATION OF THE MARKER

- (1) Set the MODE Switch in the "AM" position and BAND Switch in the "10MHz" position, then turn ON the POWER Switch.
- (2) The FREQUENCY DISPLAY will show "10.100.0". Turn the TUNING CONTROL knob to tune to WWV (or other standard frequency station) on 10.000MHz. Set the TUNING RATE Switch in 10Hz steps for fine tuning.
- (3) Turn ON the marker switch on the unit and adjust the FREQUENCY ADJUST trimmer on the unit to make "zero beat" with WWV.
- (4) When you have performed the calibration, turn OFF the marker switch.

5. CALIBRATION OF THE TRANSCEIVER

- (1) Set the MODE Switch in the CW position and the TUNING RATE Switch in 100Hz position. Tune to the lower band edge of the band you want to calibrate, as an example, "21.000.0".
- (2) Ground the Key jack on the rear panel so that the CW sidetone becomes audible. (Don't transmit.)
- (3) Turn ON the marker switch, and adjust the FREQUENCY SET control of the set, so that the two tones are of the same pitch (in zero beat).
- (4) The frequency calibration is sufficient on a frequency on the same band, but it is required for each band.

6-3-2 INSTALLATION OF THE IC-EX203 (CW AUDIO FILTER UNIT)

1. PARTS LAYOUT

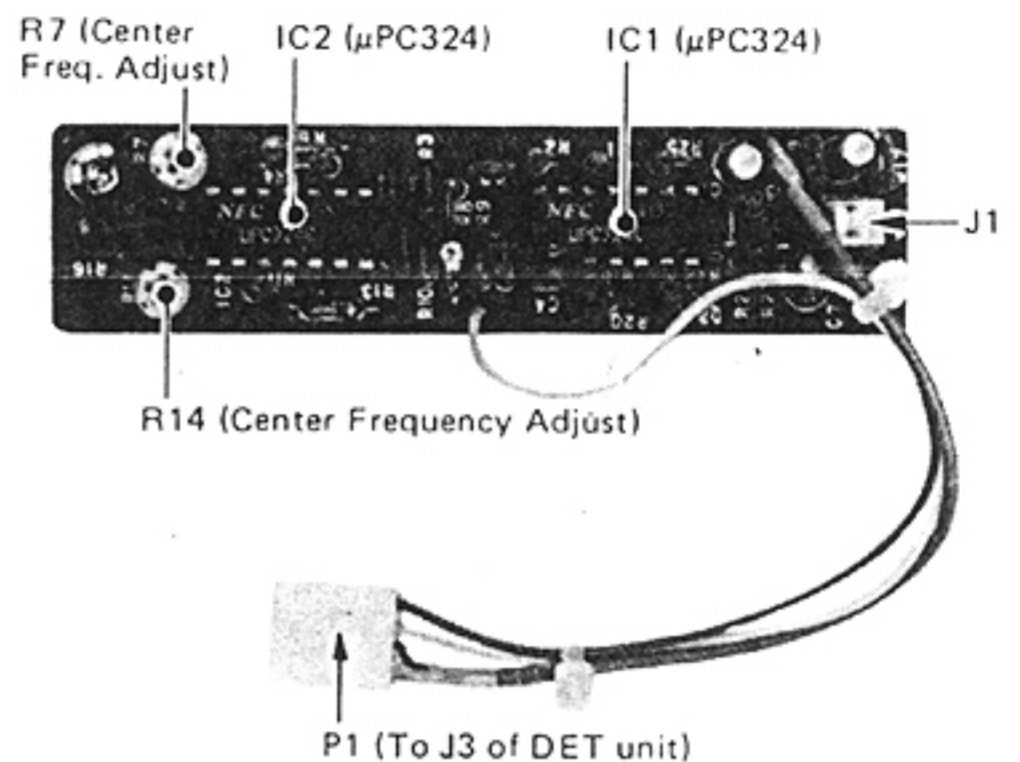

2. INSTALLATION PROCEDURE

- (1) Loosen two retaining screws of the upper sub-chassis, and turn the sub-chassis around hinges on the other end as shown in the photo.

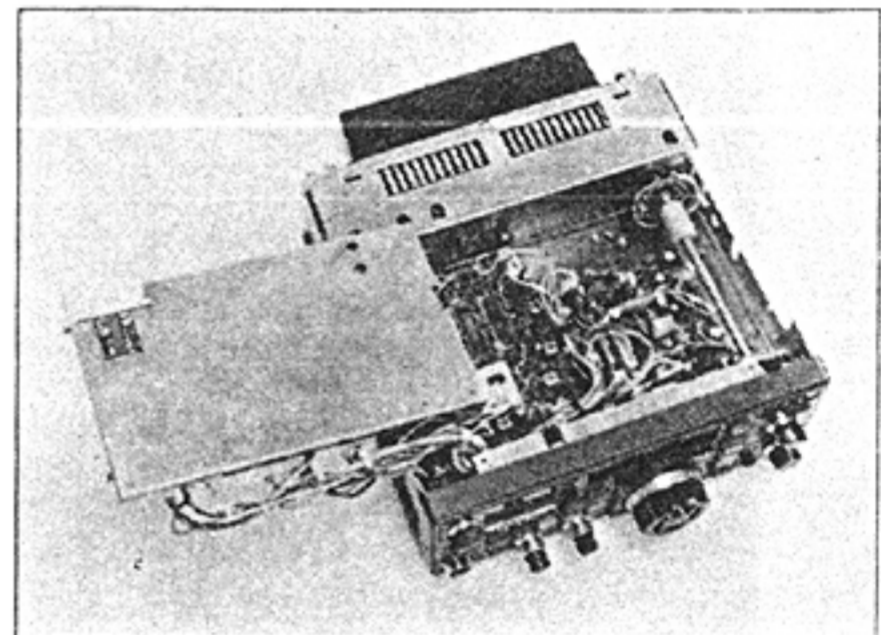

- (2) Loosen the front side screw of the shaft coupling sleeve of the band switch and remove the shaft sliding toward front side.

Install this unit to the position shown in the photo, using screws that have been attached.

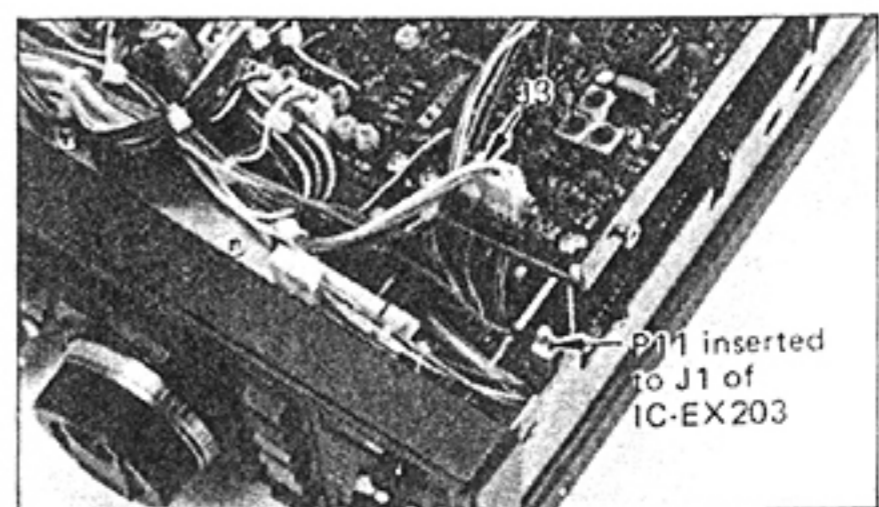
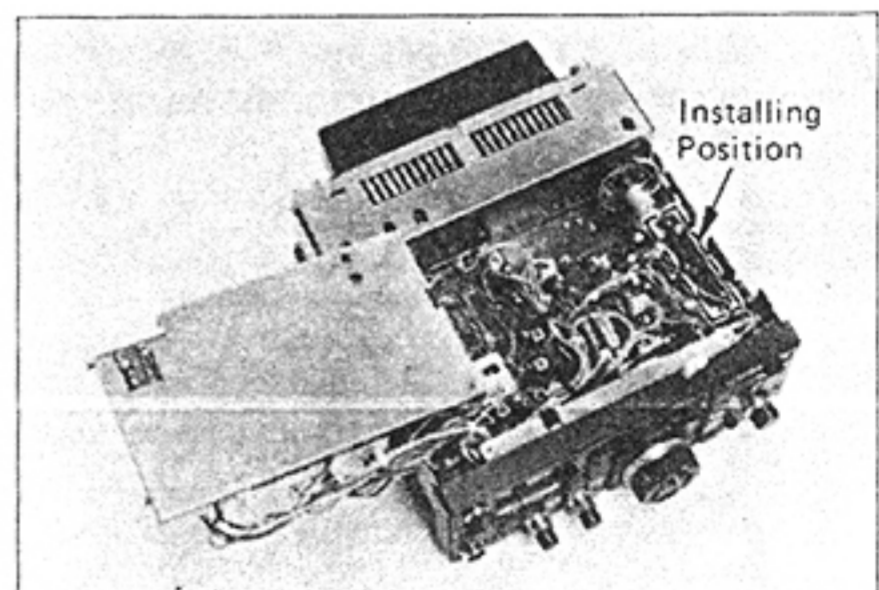

- (3) Replace the shaft and the upper sub-chassis. Unplug P11 inserted to J3 of the DET unit and plug it to J1 of IC-EX203.
- (4) Plug P1 of IC-EX203 to J3 of the DET unit. Tighten the retaining screws of the sub-chassis.
- (5) This unit does not require an adjustment, and provides 150Hz/6dB pass band when the set is in the CW mode.

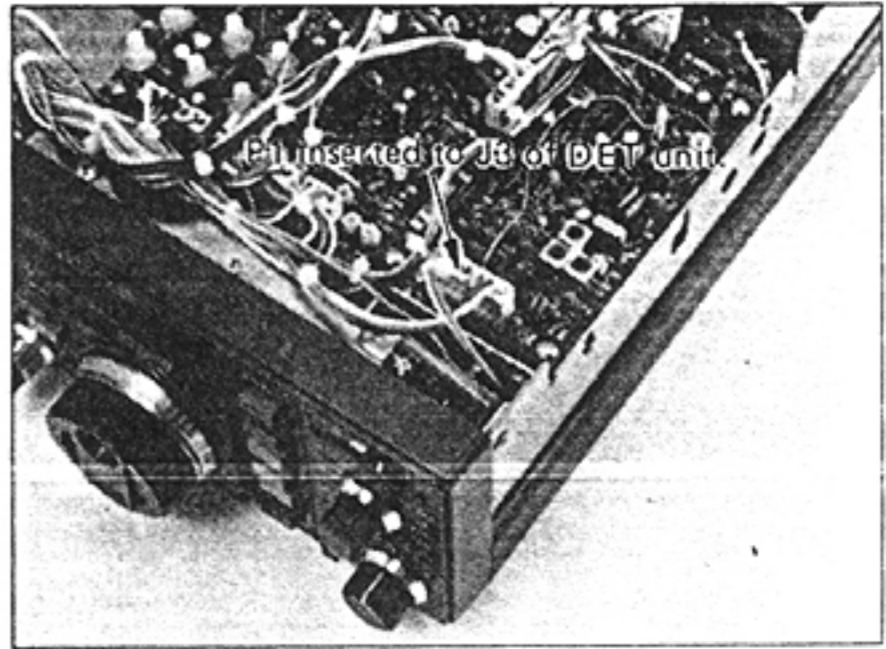

6 - 3 - 3 INSTALLATION OF THE IC-EX202 (LDA UNIT)

1. PARTS LAYOUT

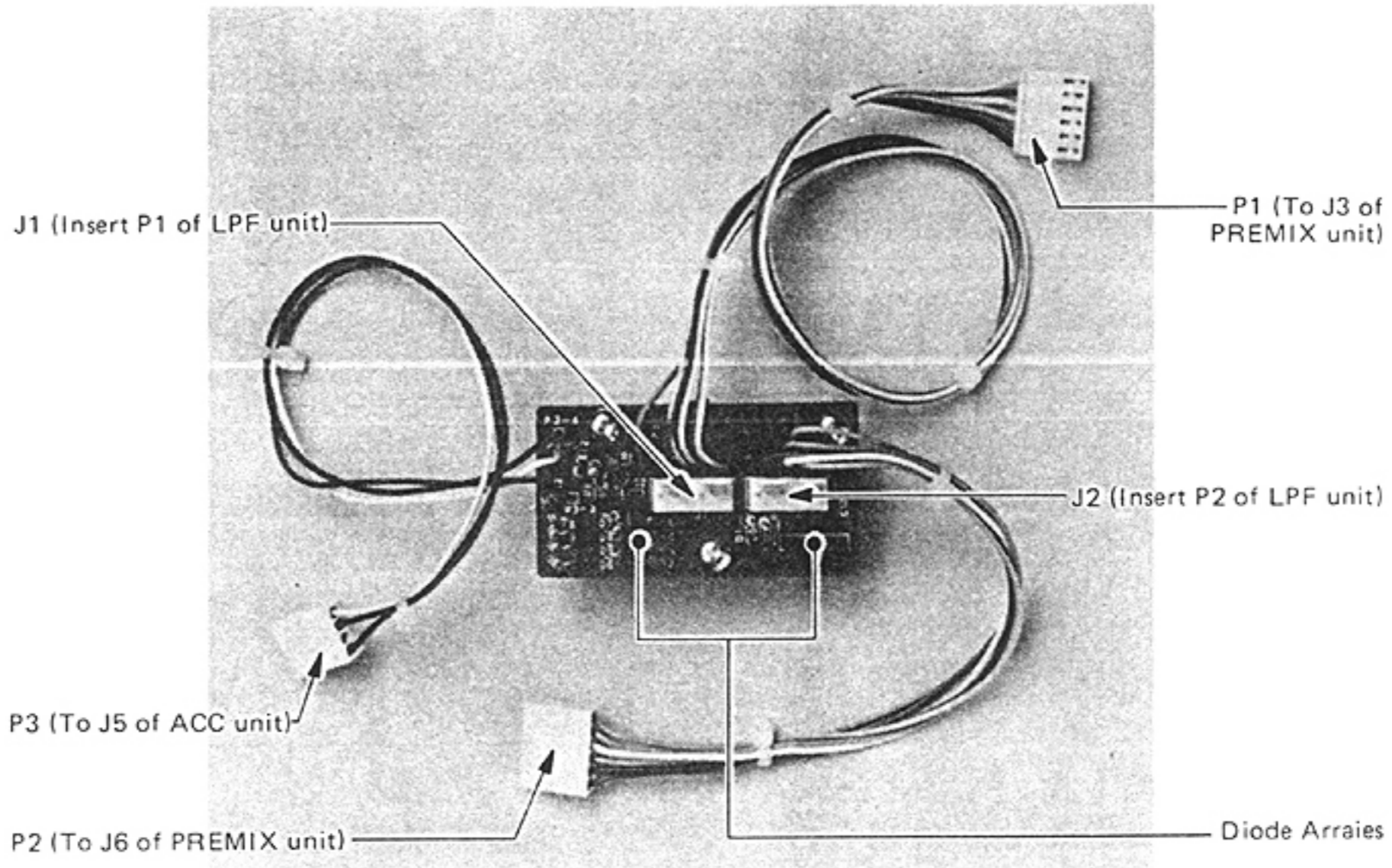

2. INSTALLATION PROCEDURE

- (1) Loosen the two retaining screws of the upper sub-chassis, and turn the sub-chassis around hinges on the other end as shown in the photo.

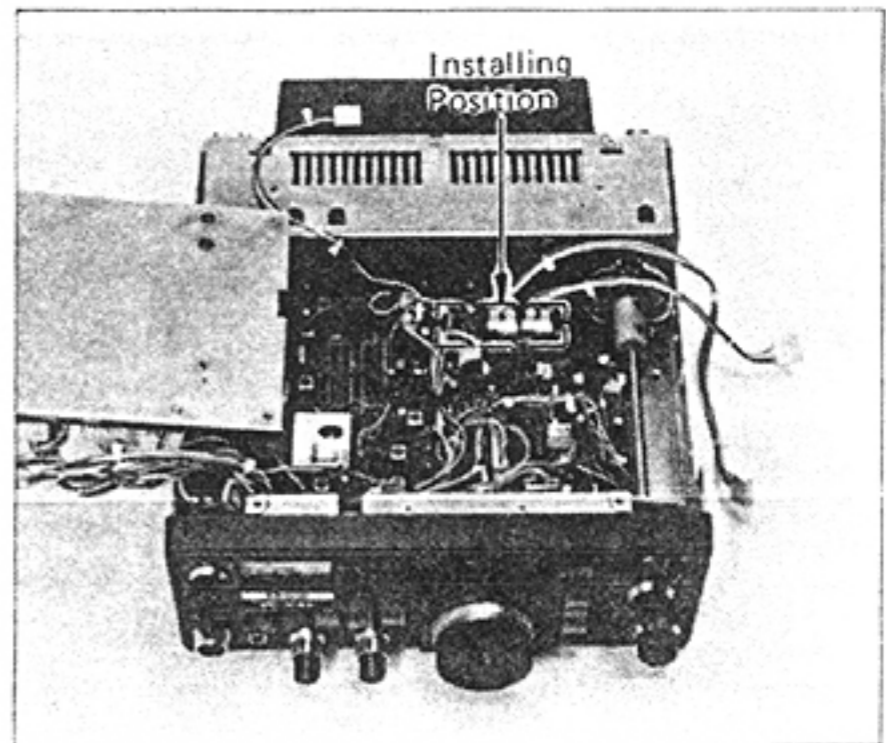
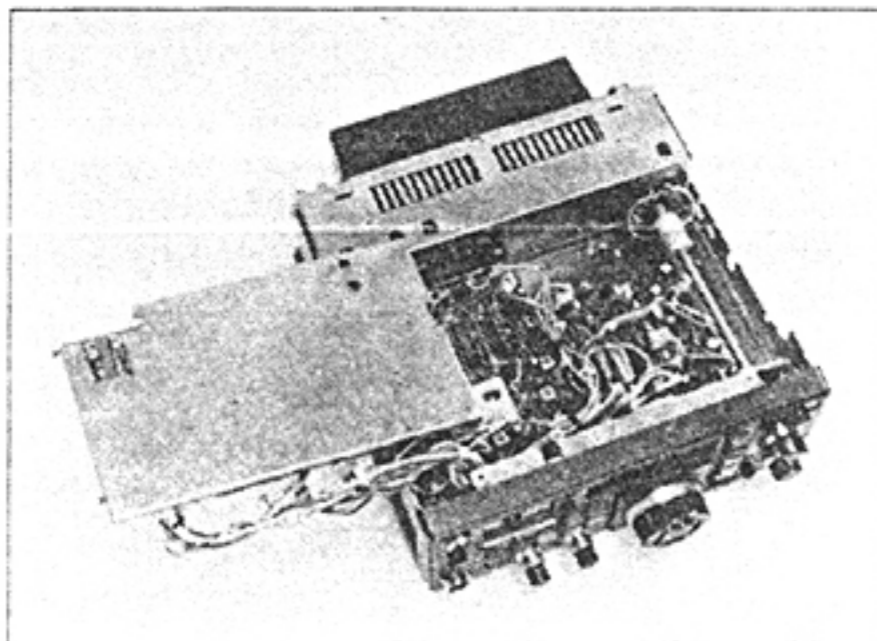

- (2) Install this unit to the position shown in the photo using the screws that have been attached.
- (3) Unplug P1 and P2 from J3 and J6 of the PREMIX unit located the bottom side.

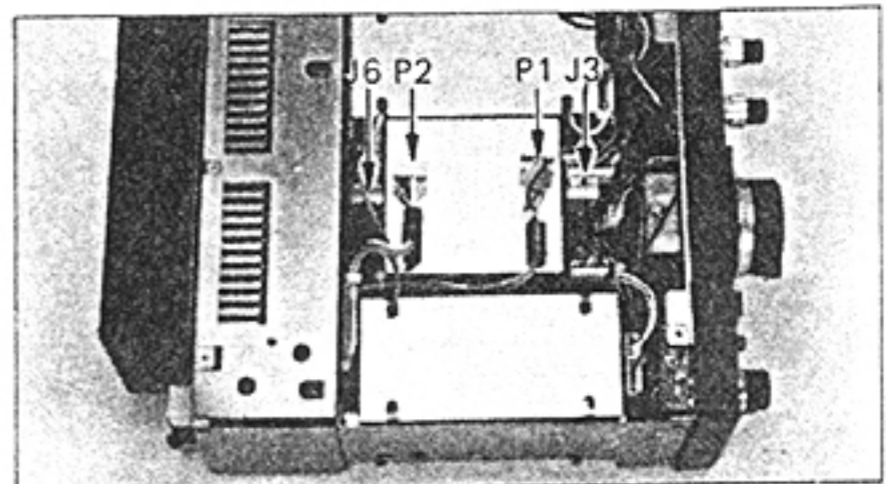

- (4) Loosen the screws of the shaft coupling sleeve of the band switch, and remove the shaft, sliding it towards the front side, then the sleeve and the spring pressing wafer of the band switch.

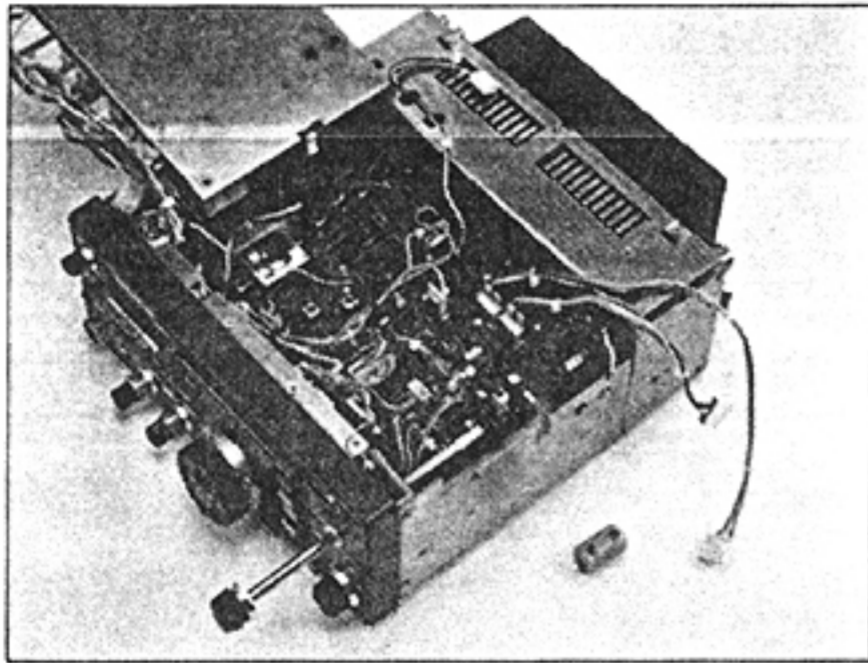

- (5) Remove the wafer of the band switch from its shaft, taking care not to damage the wafer.

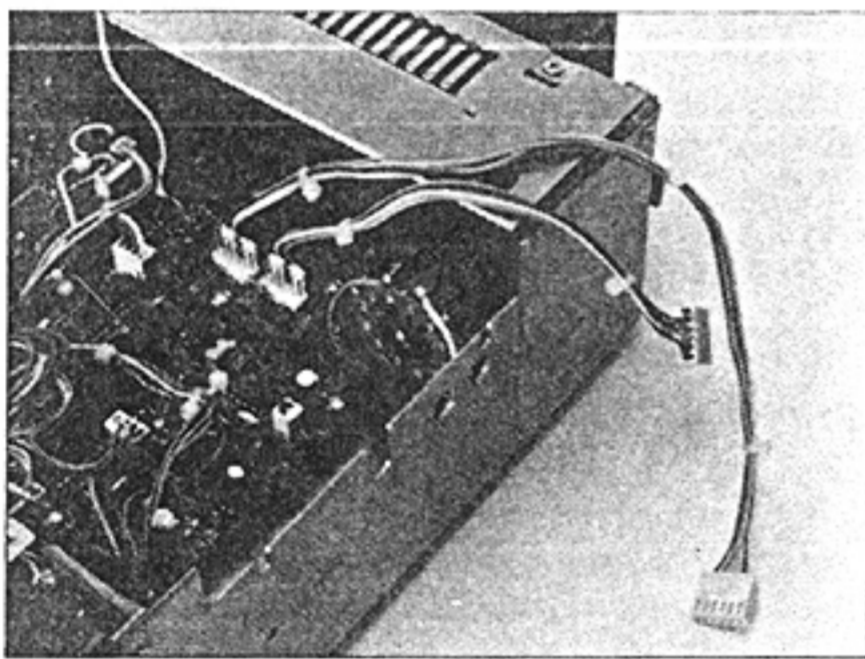

- (6) Remove the cover of the PLL unit, and unplug connectors inserted to the unit. Then unscrew the four screws retaining the unit, and remove the unit from the chassis.

- (7) Remove the wafer and its wiring harness through the slot under the band switch toward upper side.

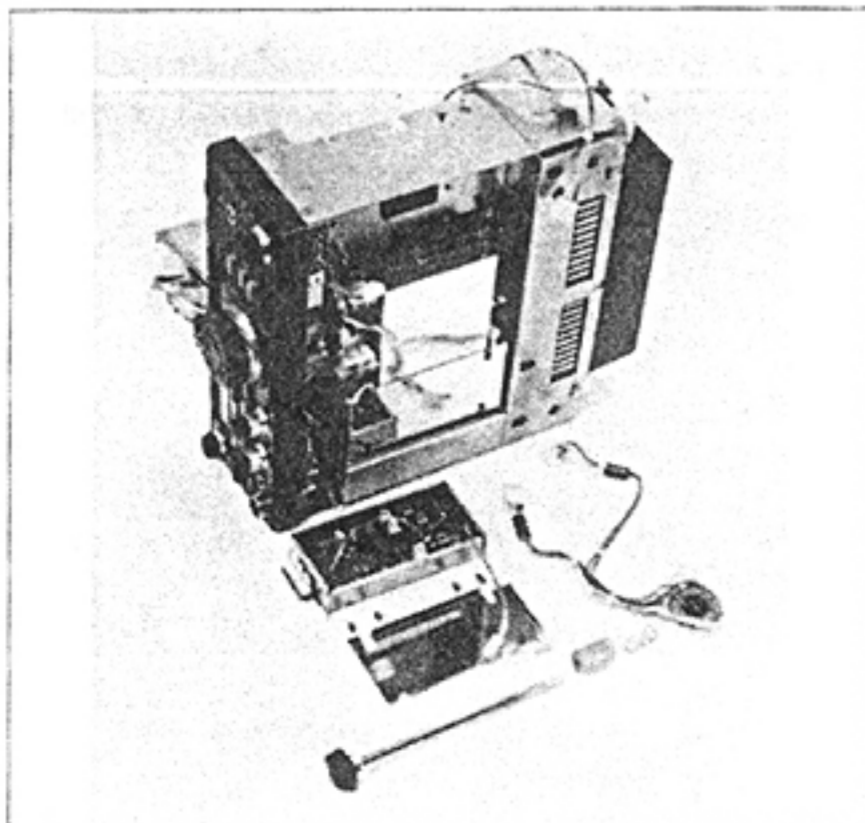

- (8) Run the cords with P1 and P2 of the LDA unit through the slot under the band switch. Plug P1 (6-pin plug attached to longer wires) to J3 and P2 (6-pin plug) to J6 of the PREMIX unit, so that the colors of the wires are the same order.

Replace the PLL unit by the reverse procedure of (6).

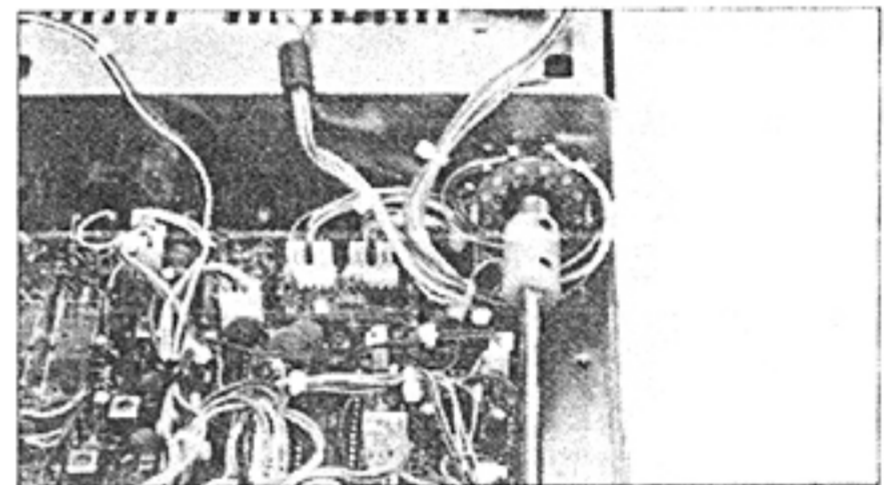
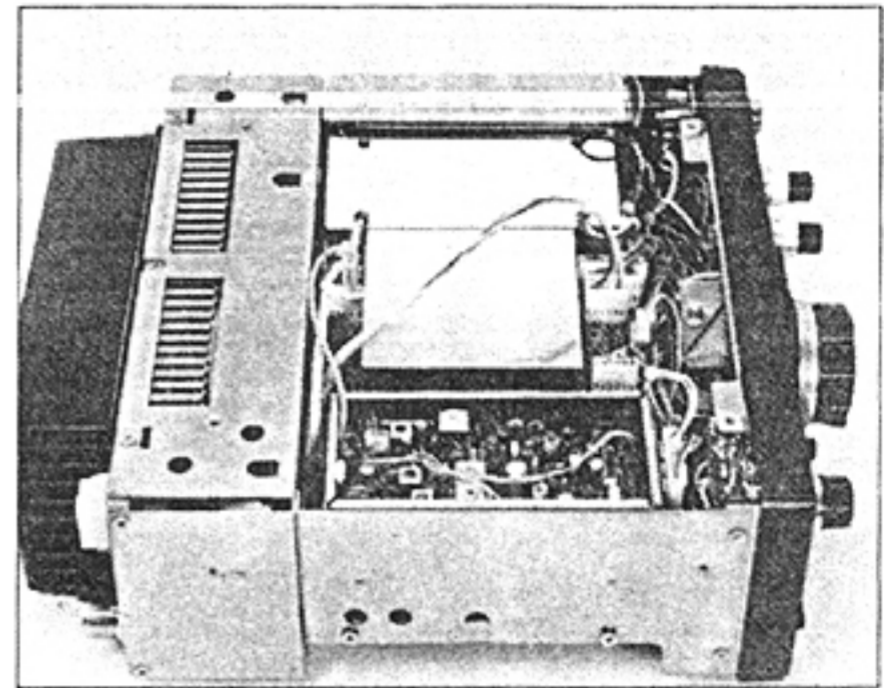

- (9) Replace the wafer, spring, shaft and shaft coupling sleeve by the reverse procedure of (4) and (5).

- (10) Plug P1 (6-pin plug attached to longer wires) of the switch wafer to J1 of the LDA unit and P2 (6-pin plug) to J2.

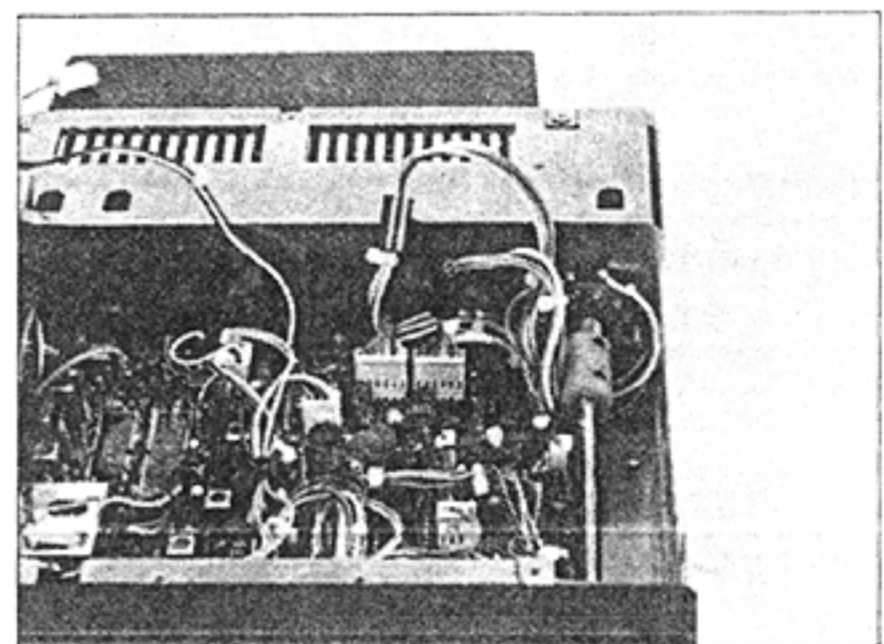

- (11) Remove the eight screws at each end of the rear panel.

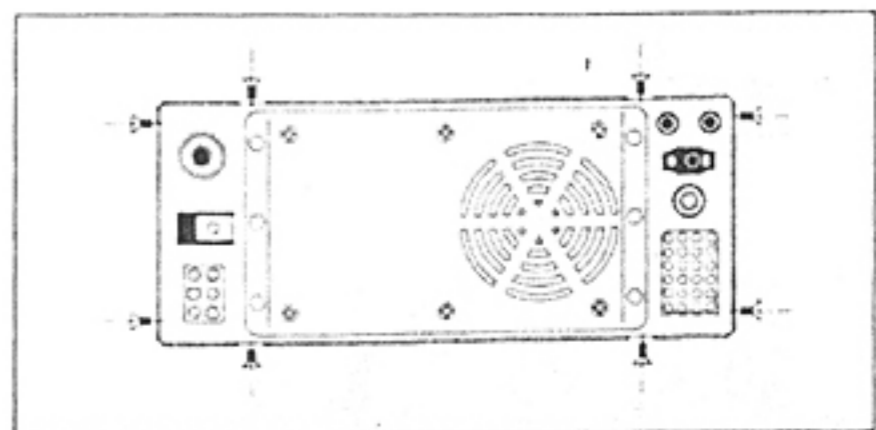

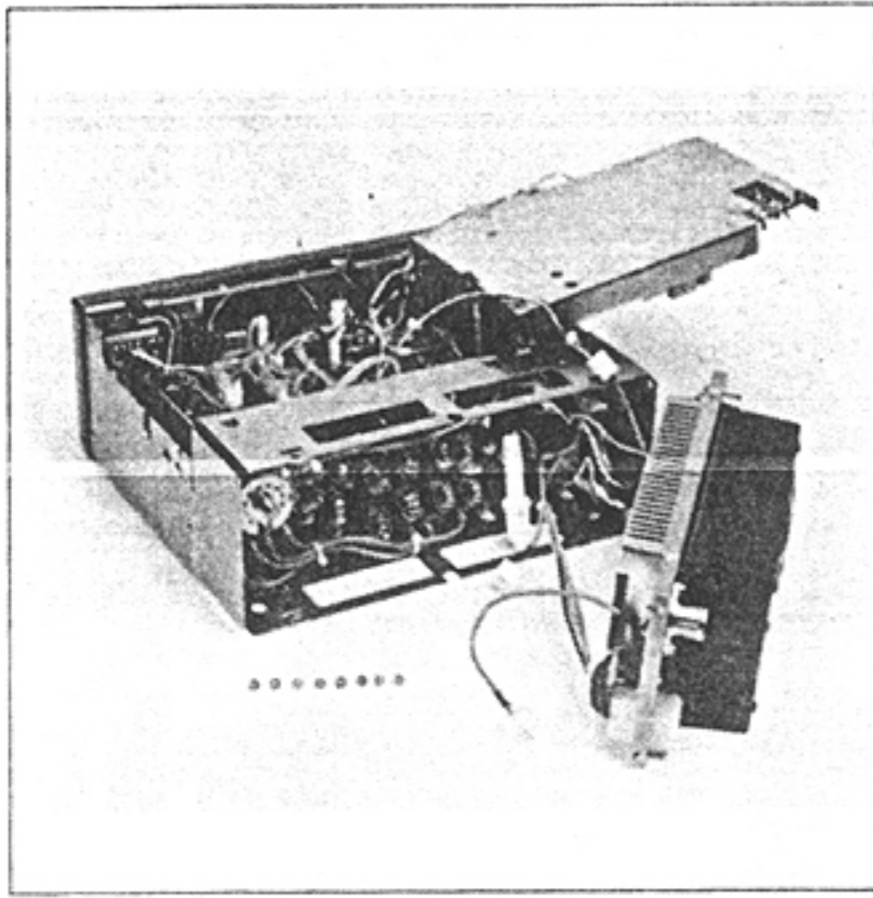

(12) Turn over the rear panel right side, and unplug coaxial cables from J1 and J3 on the LPF board.

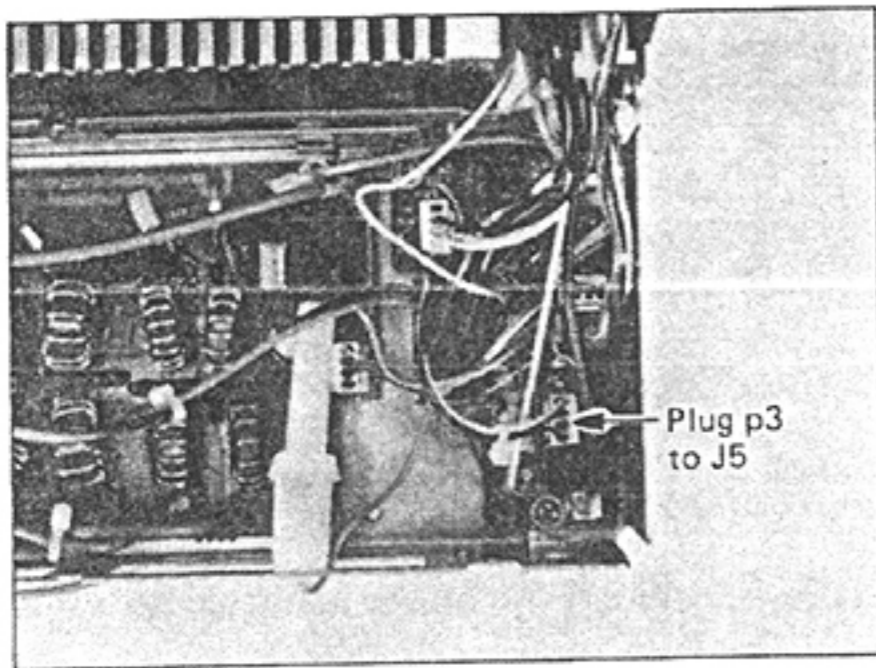

(13) Run the cord with P3 (4-pin plug) of the LDA unit through the slot at the right corner of the rear box. Then plug P3 to J5 of the ACC unit.

(14) Replace unplugged connectors and the rear panel by the reverse procedure of (11) and (12).

This unit has no requirement for adjustment for operation.

3. CHECKING THE OPERATION

Connect a multimeter across Pin 13 (+) and Pin 8 (-) of the accessory socket on the rear panel.

Make sure the voltage shown in the chart is put out across the pins on each band.

Band Control Voltage Chart

BAND (MHz)	Band Control Voltage
3.5	6.0 ~ 6.5V
7	5.0 ~ 5.5V
14	4.0 ~ 4.5V
18 - 21	3.0 ~ 3.5V
24 - 28	2.0 ~ 2.5V
10	0 ~ 1.2V

6-3-4 INSTALLATION OF IC-EX205 (TRV UNIT)

1. PARTS LAYOUT

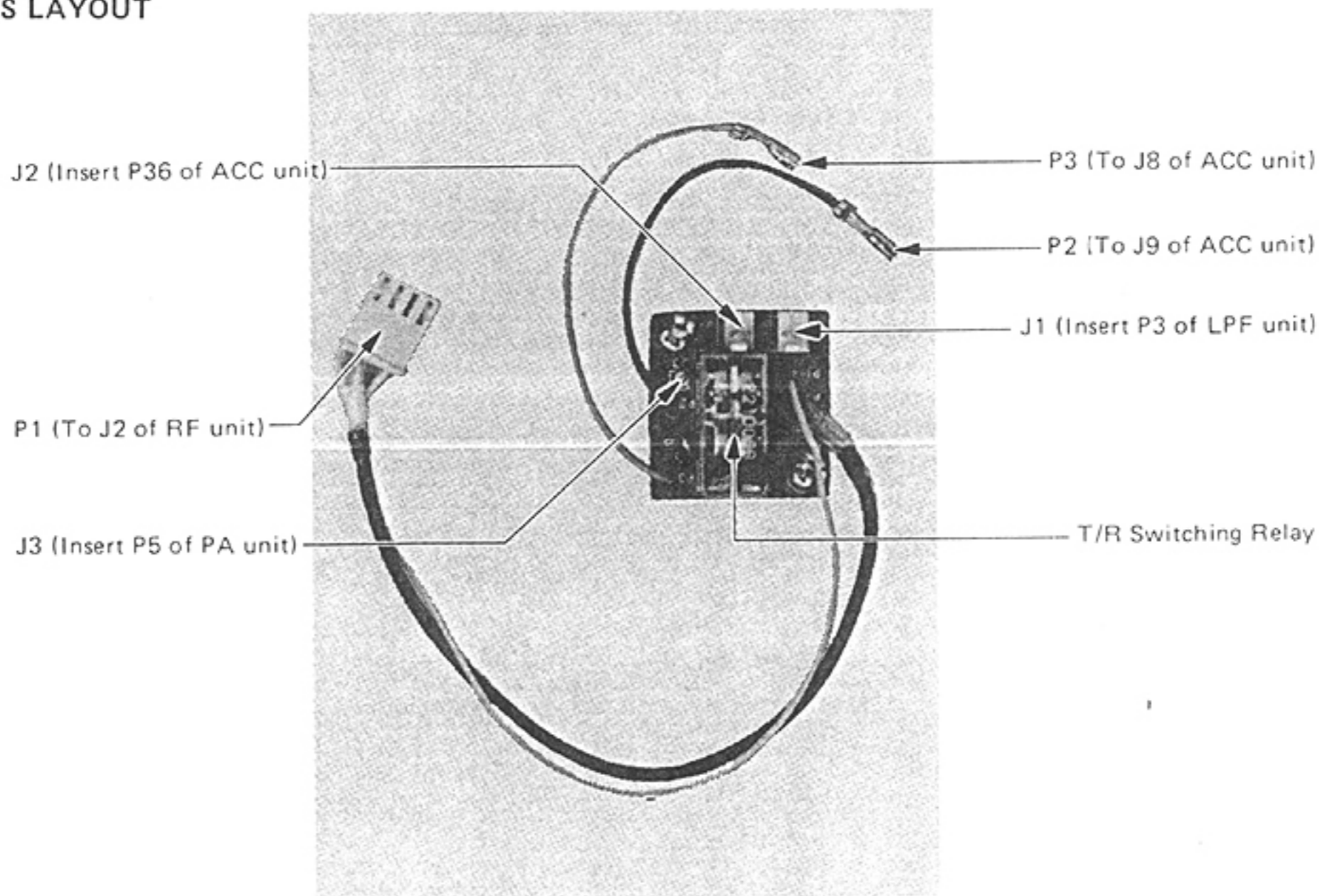

2. INSTALLATION PROCEDURE

- (1) Remove the eight screws at each end of the rear panel.
- (2) Turn over the rear panel right side or put it on the chassis, and unplug coaxial cables from J1 and J3 on the LPF unit.
- (3) Install this unit to the position shown in the photo using the screws that have been attached.

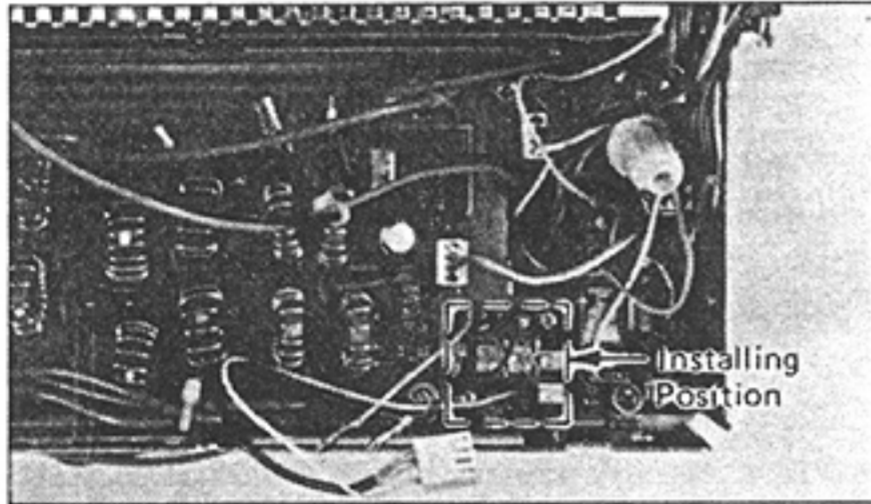

- (4) Connect P2 (with green wire) to J9 on the ACC unit, unplug P36 (2-pin plug) inserted J2 on the ACC unit, and plug it to J2 in the TRV unit.

Unplug P5 (orange wire from the PA unit) from J8 on the ACC unit and plug it to J3 on the TRV unit, and plug P3 (with orange wire) of the TRV unit to J8 on the ACC unit.

Unplug P3 (2-pin plug with coaxial cable from the LPF unit) from J2 on the RF unit, and plug it to J1 on the TRV unit. Then plug P1 (4-pin plug) of the TRV unit to J2 on the RF unit.

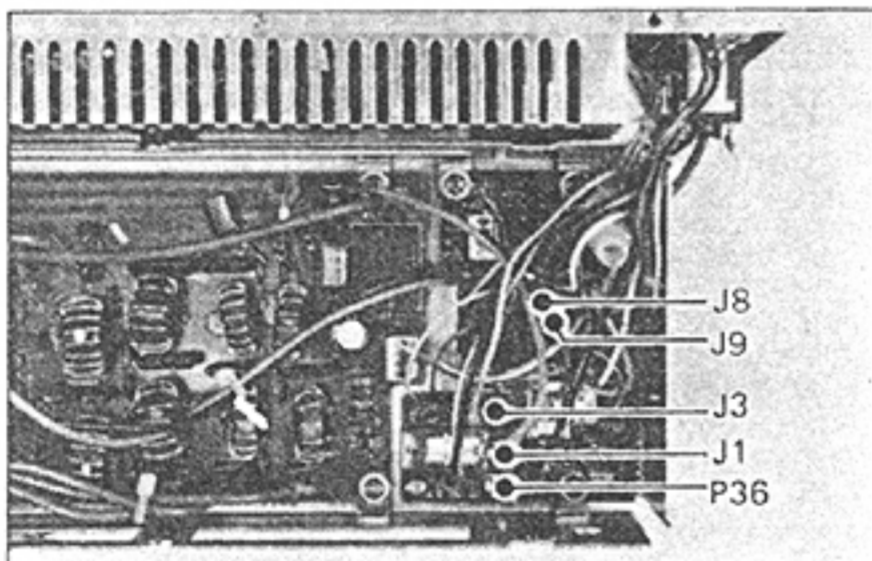

- (5) Replace unplugged connectors and the rear panel by the reverse procedure of (1) and (2).

3. OPERATION

This unit has no requirement for adjustment for the operation.

When the transverter control signal (+8V) is applied to Pin 11 of the ACCESSORY socket, the ALC terminal on the rear panel can be used for a VHF/UHF transverter INPUT/OUTPUT terminal.

The transverter's input/output frequency and signal level should be as follows:

- Transverter INPUT/OUTPUT Frequency
28 ~ 30MHz
- Input/Output signal level
Transmit (Output): Max 150mV across a 50 ohm load
Receive (Input): 1μV for S/N 10dB

6 - 3 - 5 INSTALLATION OF THE FL-44 (A)

1. INSTALLATION PROCEDURE

- (1) Unscrew the screws retaining the MAIN unit board and DET unit board, then turn them over so that foil side of the boards can be seen.

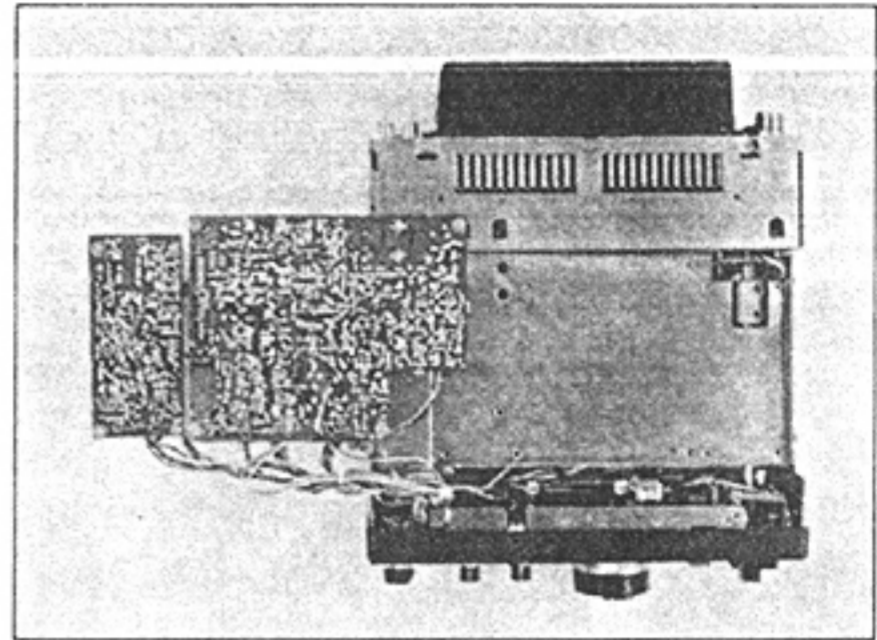

- (2) Remove the solder of the mechanical filter's terminal pins and legs on the foil of the MAIN unit, by a desoldering braid, then take off the mechanical filter.

When the mechanical filter is "MF-455-11AZ", also remove C75 ~ C78 around the filter. (In the case of "MF-455-11GZ", C75 ~ C78 are not used.)

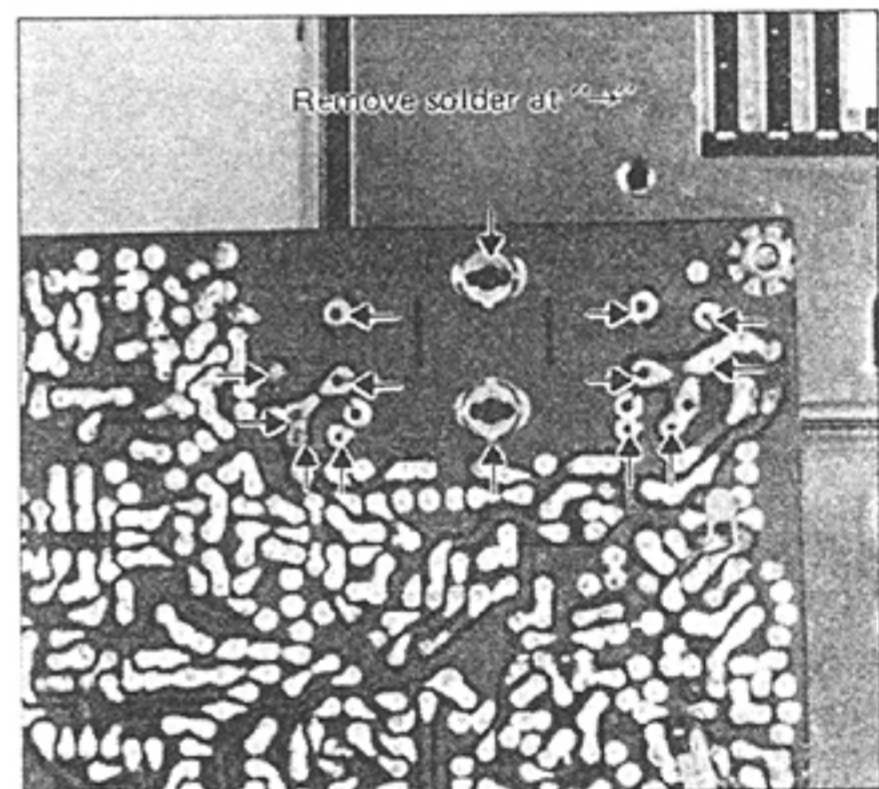

- (3) Insert the FL44 (A) to the position where the mechanical filter was installed and retain it by two supplied nuts then solder its terminal pins.

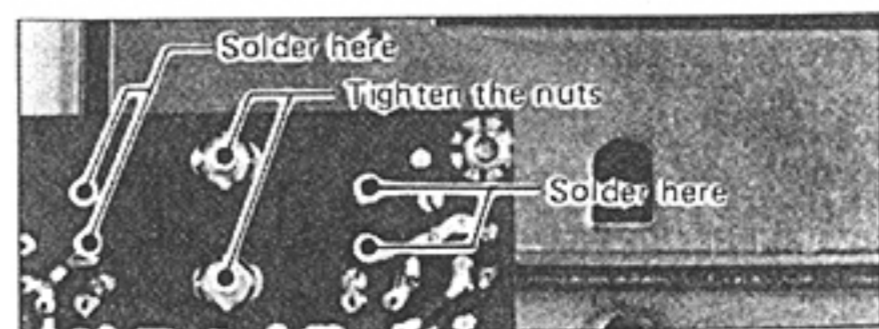

- (4) Replace the MAIN unit board and the DET unit board to the chassis by the reverse procedure of (1).

- (5) No adjustment is required for operation.

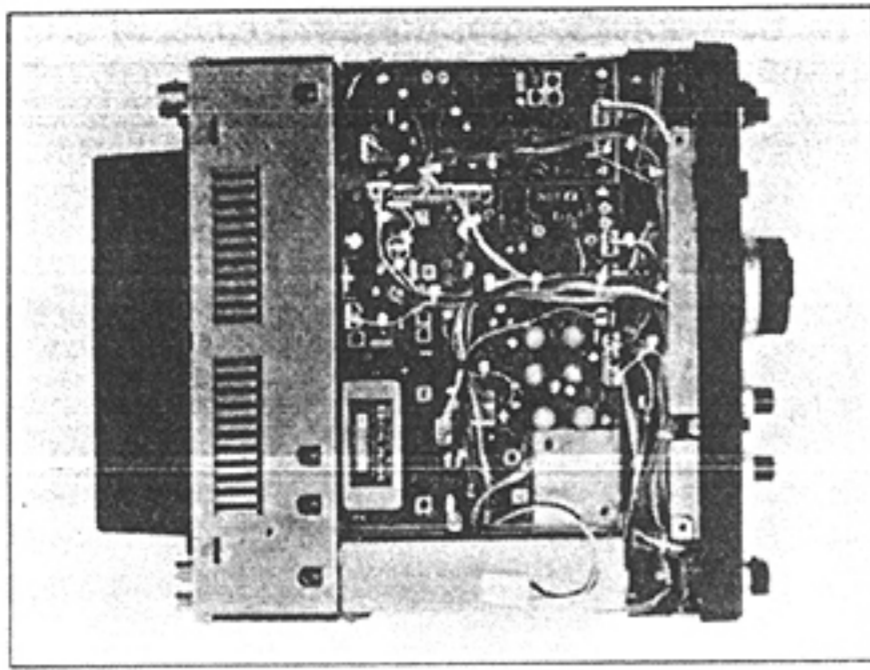

6 - 3 - 6 INSTALLATION OF THE FL-30

1. INSTALLATION PROCEDURE

- (1) Loosen two retaining screws of the upper sub-chassis, and turn the sub-chassis over around hinges on the other end as shown in the photo.

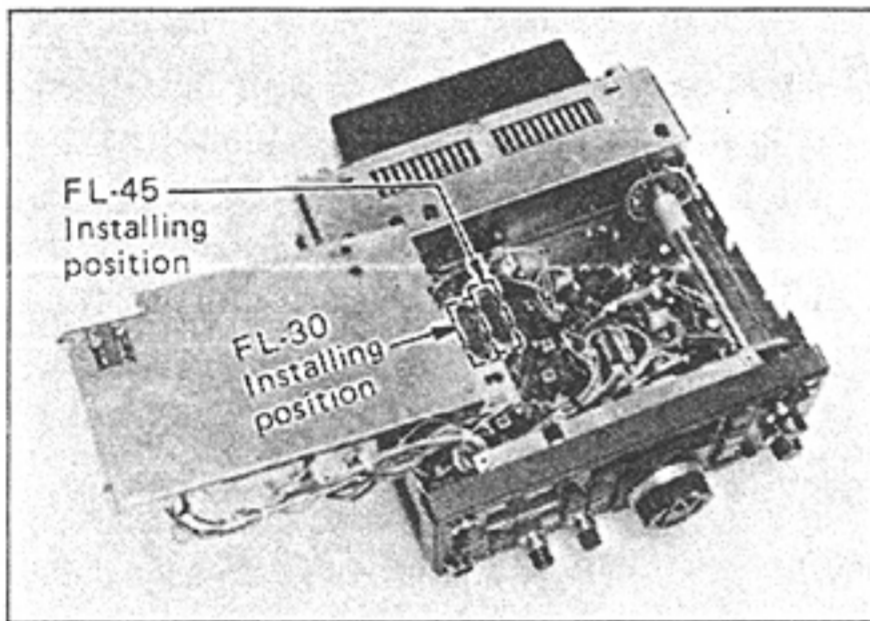

- (2) Unscrew the screws retaining the 2nd IF unit board, then turn it over so that foil side of the board can be seen.

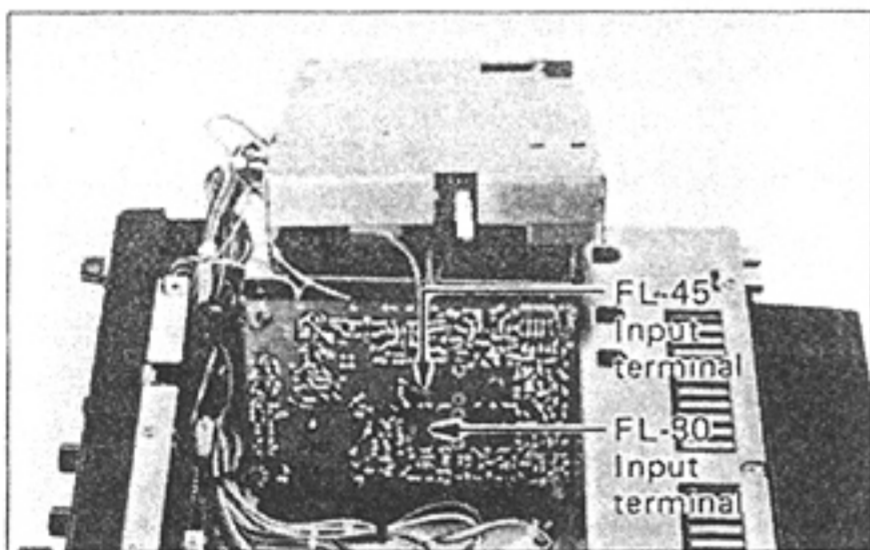

- (3) The location for the filter is shown in the photo. The holes for mounting the legs and the leads of the filter are predrilled.

Be sure to orient the filter so that the input terminal (indicated on the bottom) of the filter is facing the same direction as shown on the photo.

Insert the filter flush with the board, bend the leads and legs flush with the opposite side of the board and solder them in.

Trim the leads even with the solder points. This completes the installation.

- (4) Replace the 2nd IF unit, and unplug P3 inserted to J7 on the unit, then plug it to J8.

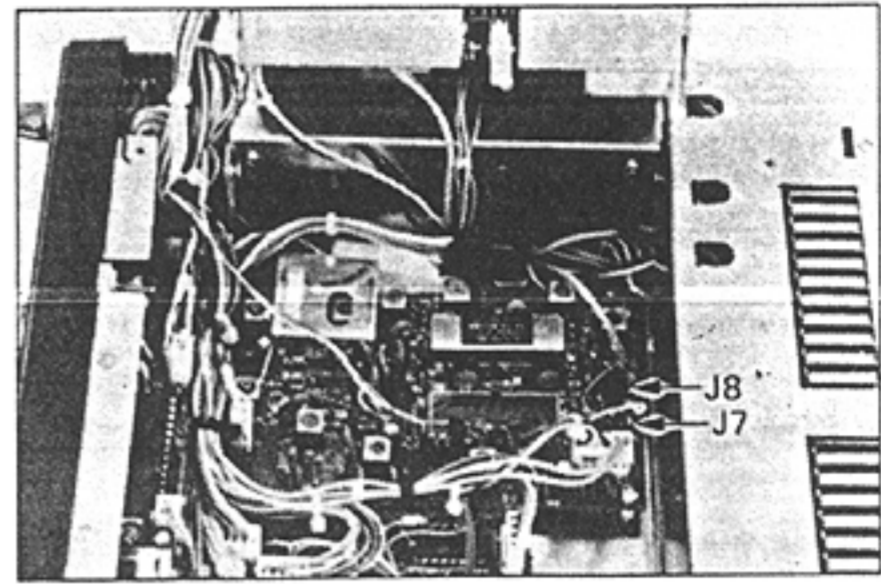

- (5) Replace the sub-chassis by the reverse procedure of (1). No adjustment is required, and the filter provides the Pass-Band Tuning system.

6 - 3 - 7 INSTALLATION OF THE FL-45

1. INSTALLATION PROCEDURE

- (1) Install the filter by the same procedure of the FL-30.
- (2) The location for the filter is shown on the photo of 6-3-6.
- (3) After replacing the 2nd IF unit board, unplug P2 inserted to J5, then plug it to J6 on the 2nd IF unit board.

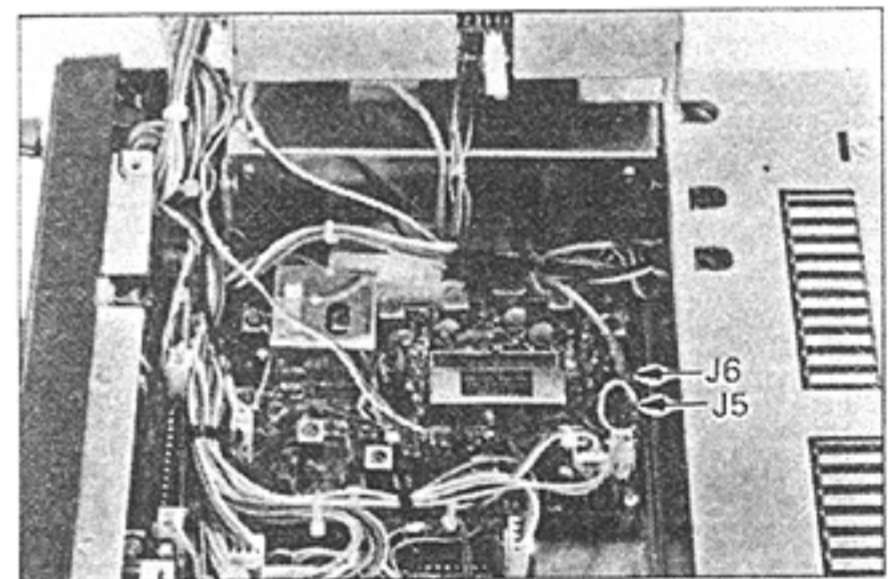

- (4) No adjustment is required, and the filter provides 500Hz/6 dB pass-band.

6-4 SCHEMATIC DIAGRAMS

IC-EX195 (MARKER UNIT)

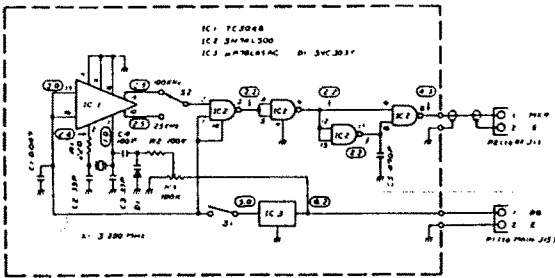

IC-EX205 (TRV UNIT)

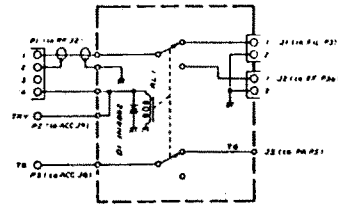

IC-EX202 (LDA UNIT)

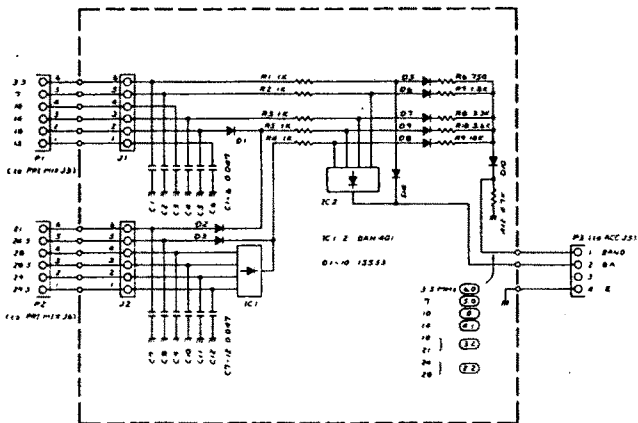

IC-EX203 (CW AUDIO FILTER UNIT)

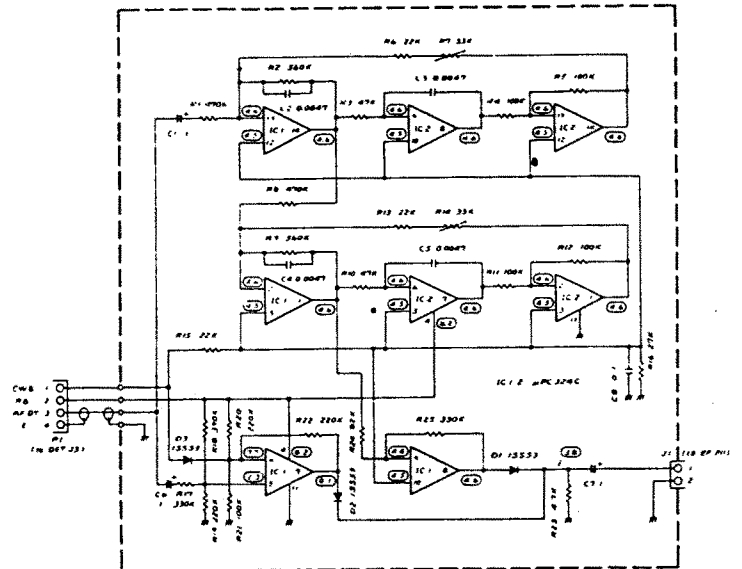

Some components subject to change for an improvement without notice.

SECTION 7 MECHANICAL PARTS AND DISASSEMBLY

PARTS ON FRONT PANEL

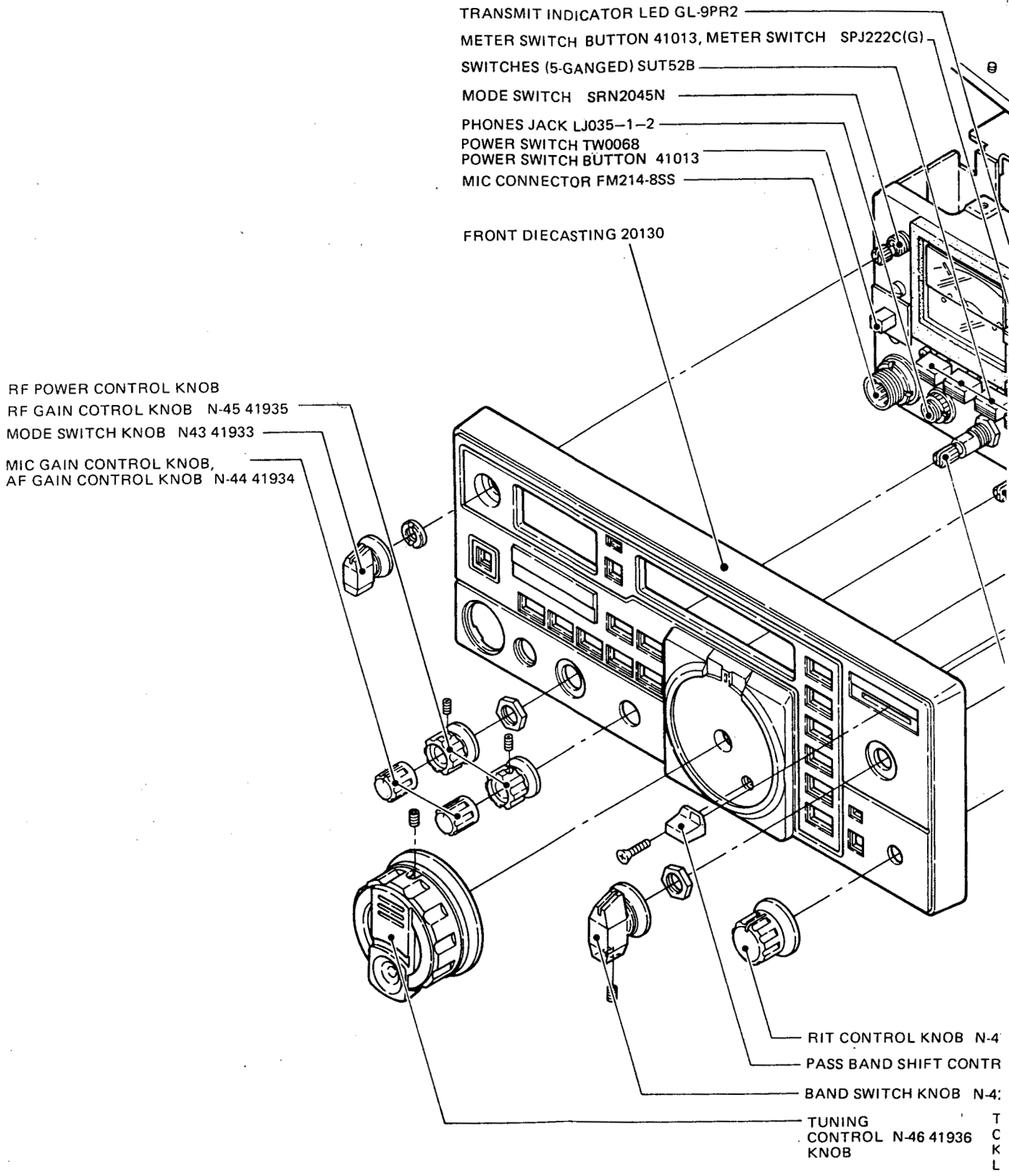

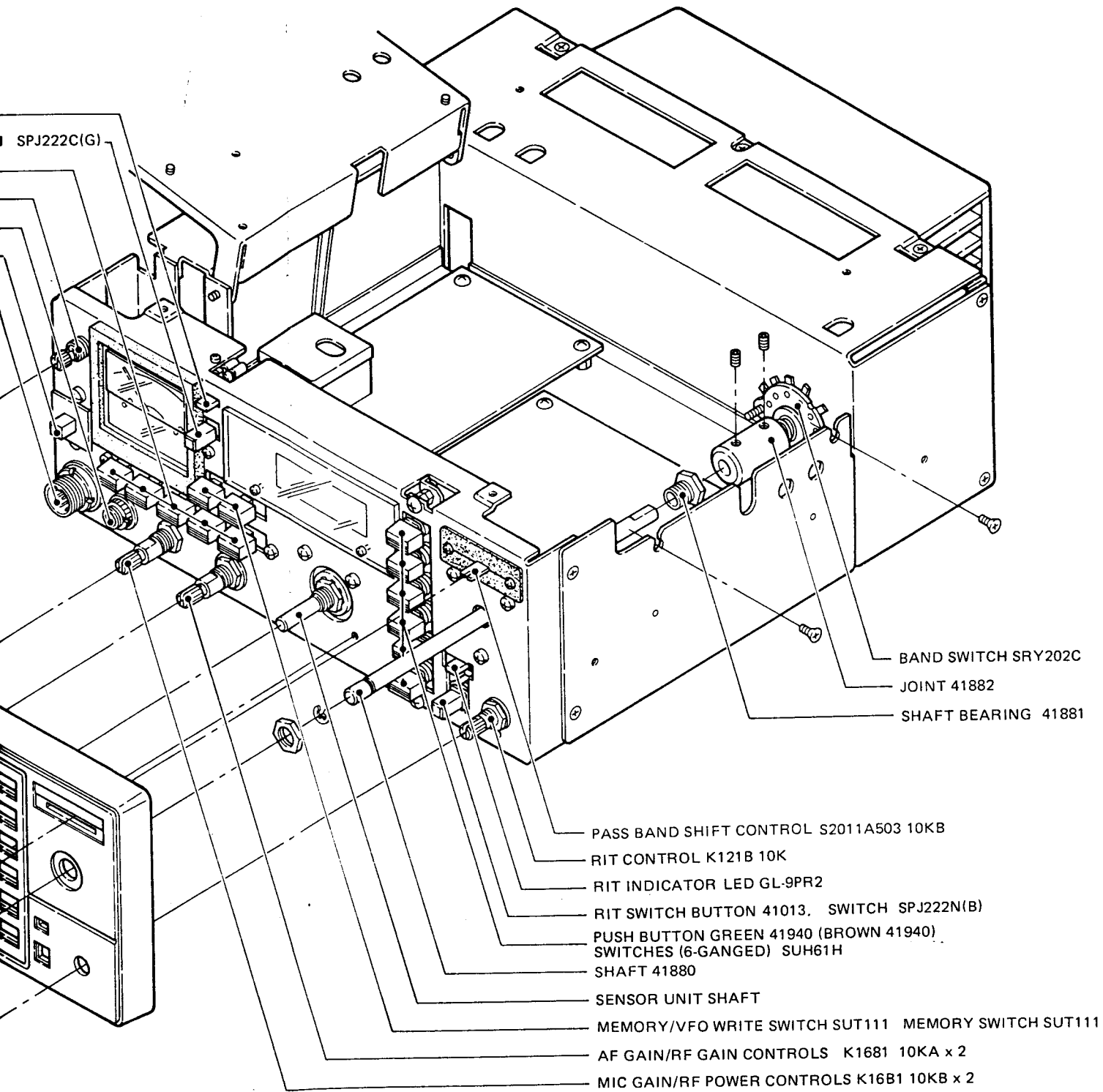

RIT CONTROL KNOB N-47 41938

PASS BAND SHIFT CONTROL KNOB N-48 41939

BAND SWITCH KNOB N-42 41857

TUNING CONTROL N-46 41936

TUNING CONTROL KNOB N-47 41937

TUNING CONTROL KNOB N-48 41938

TUNING CONTROL KNOB N-49 41939

FRONT PANEL DISASSEMBLY 1

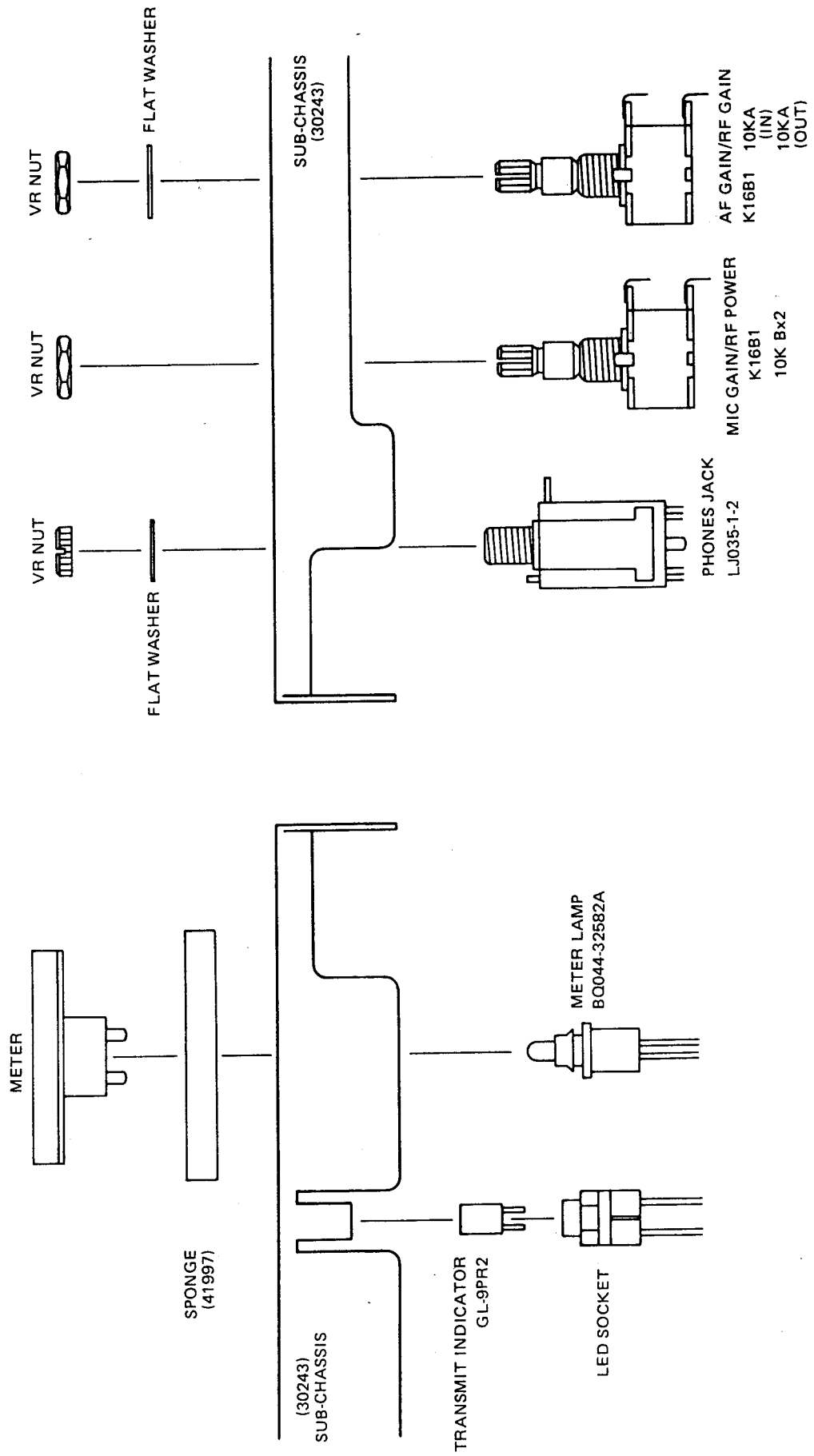

FRONT PANEL DISASSEMBLY 2

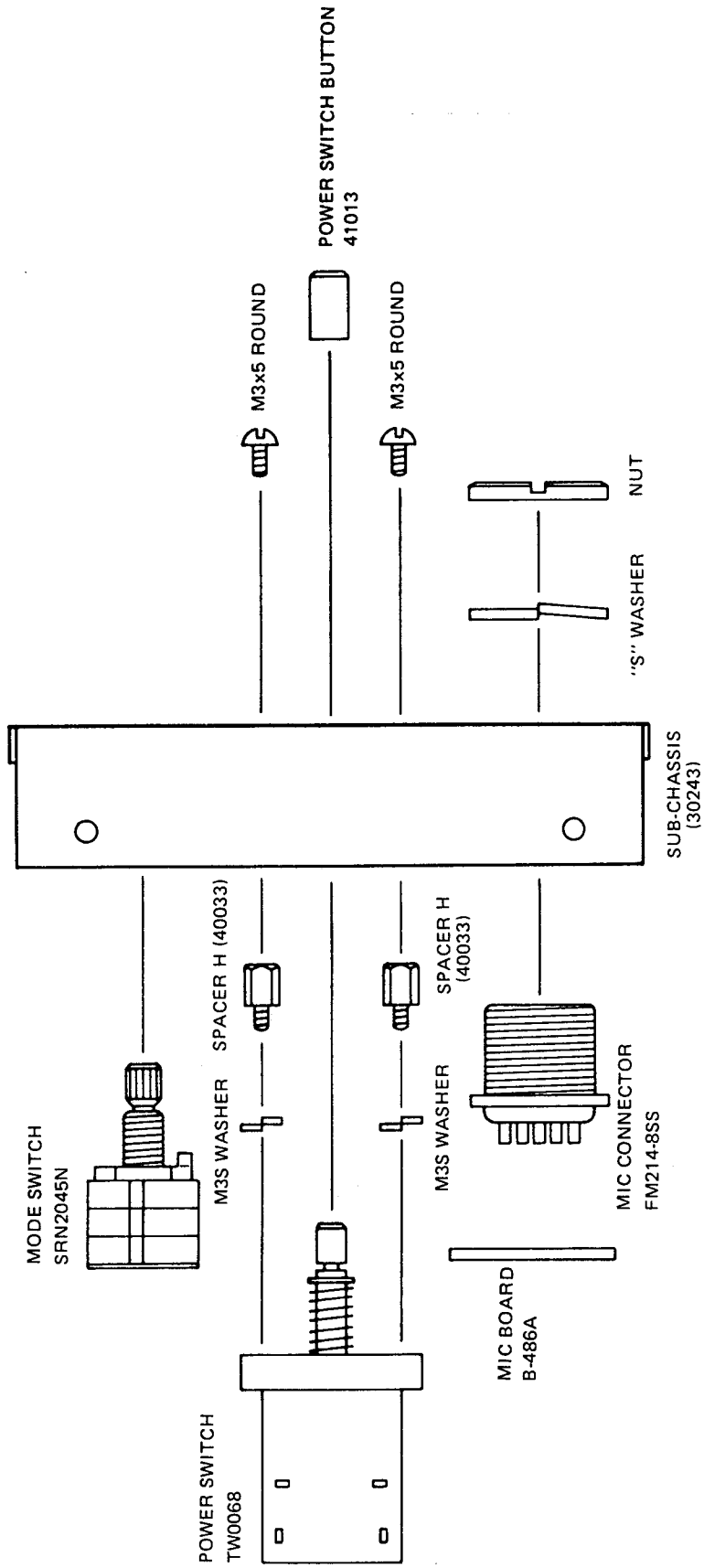

FRONT PANEL DISASSEMBLY 3

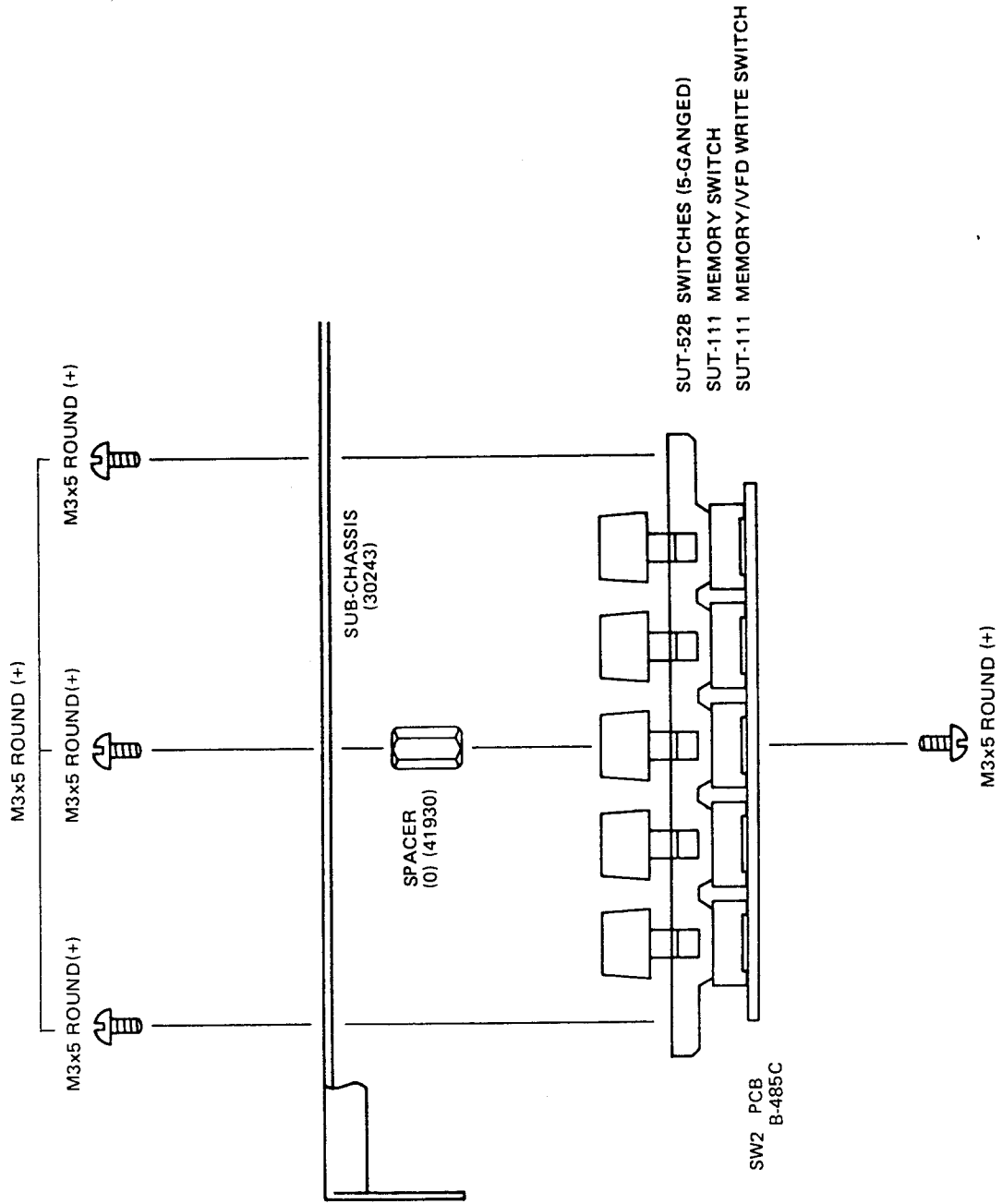

FRONT PANEL DISASSEMBLY 4

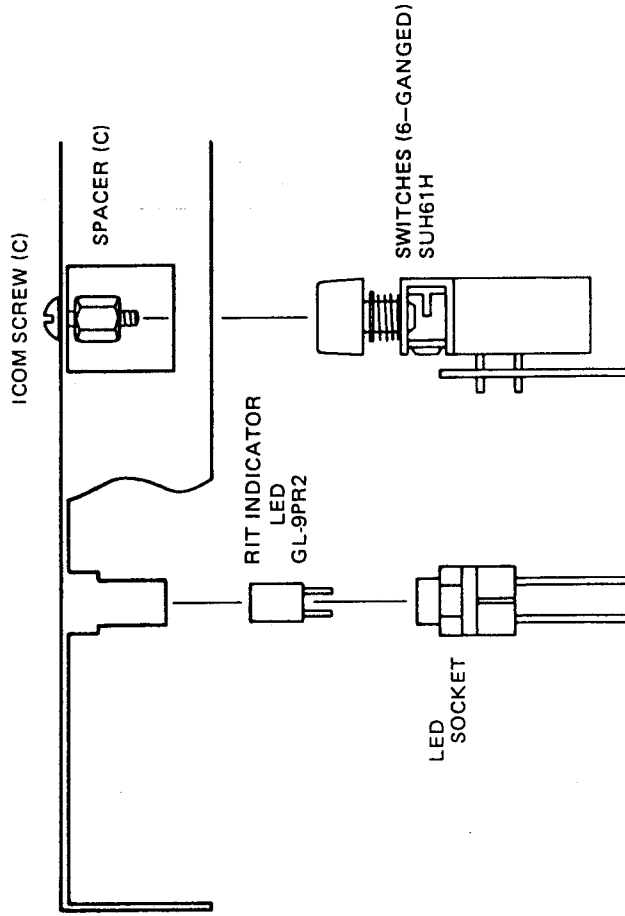
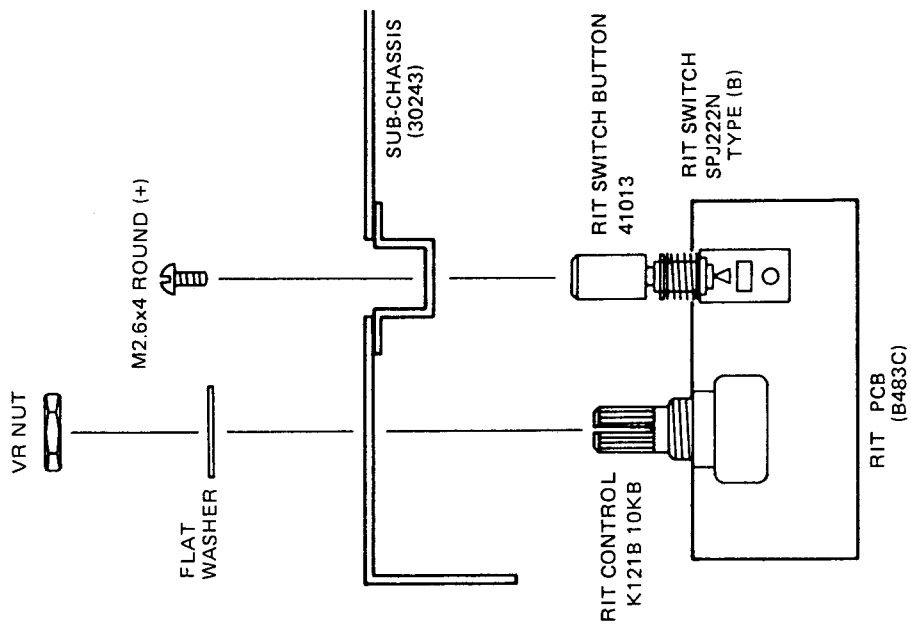

FRONT PANEL DISASSEMBLY 5

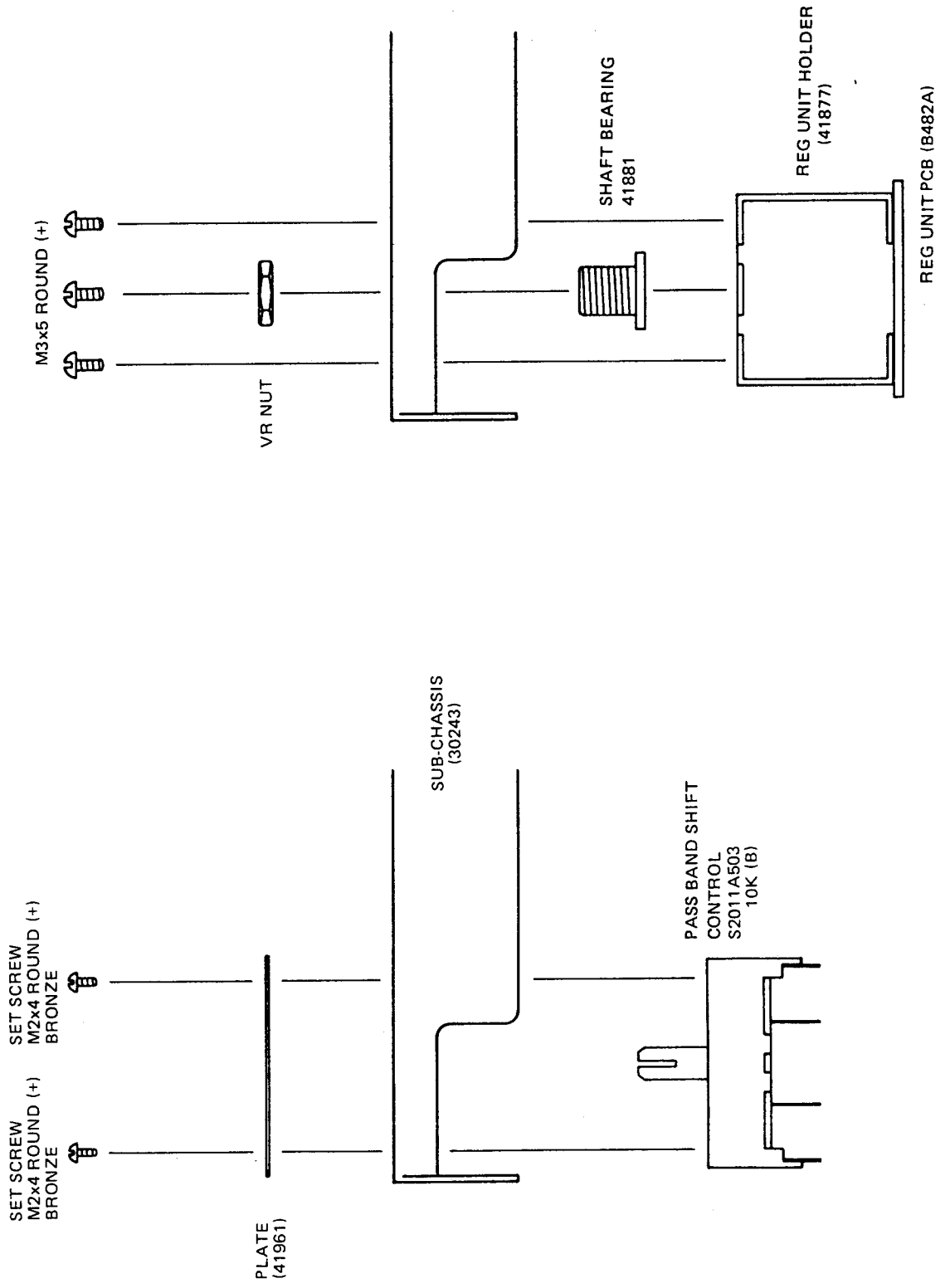

FRONT PANEL DISASSEMBLY 6

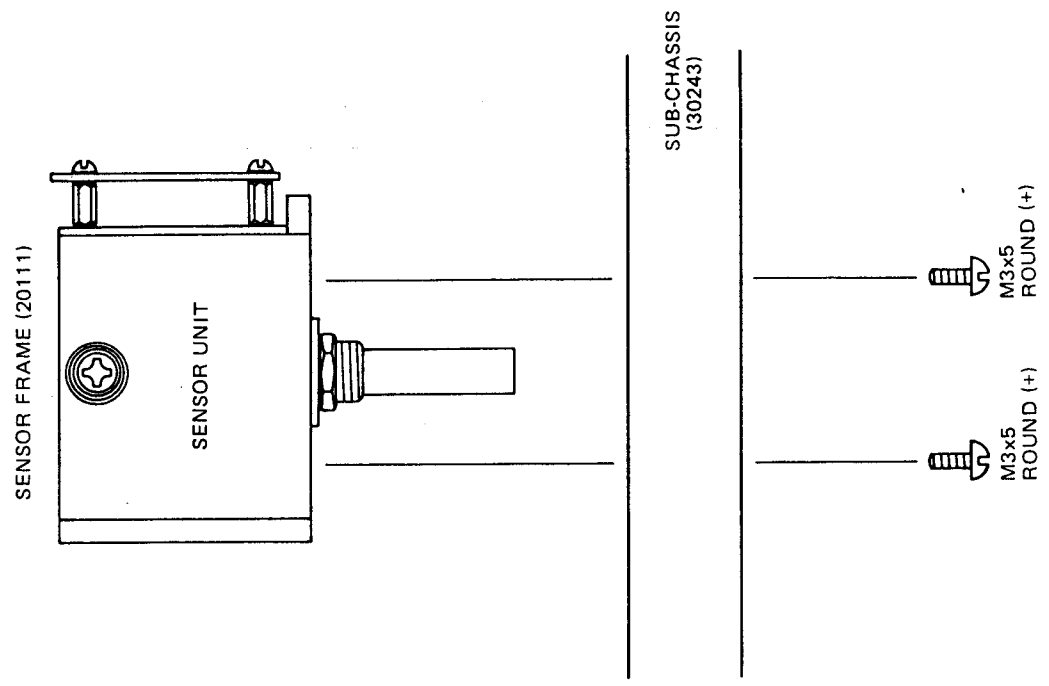
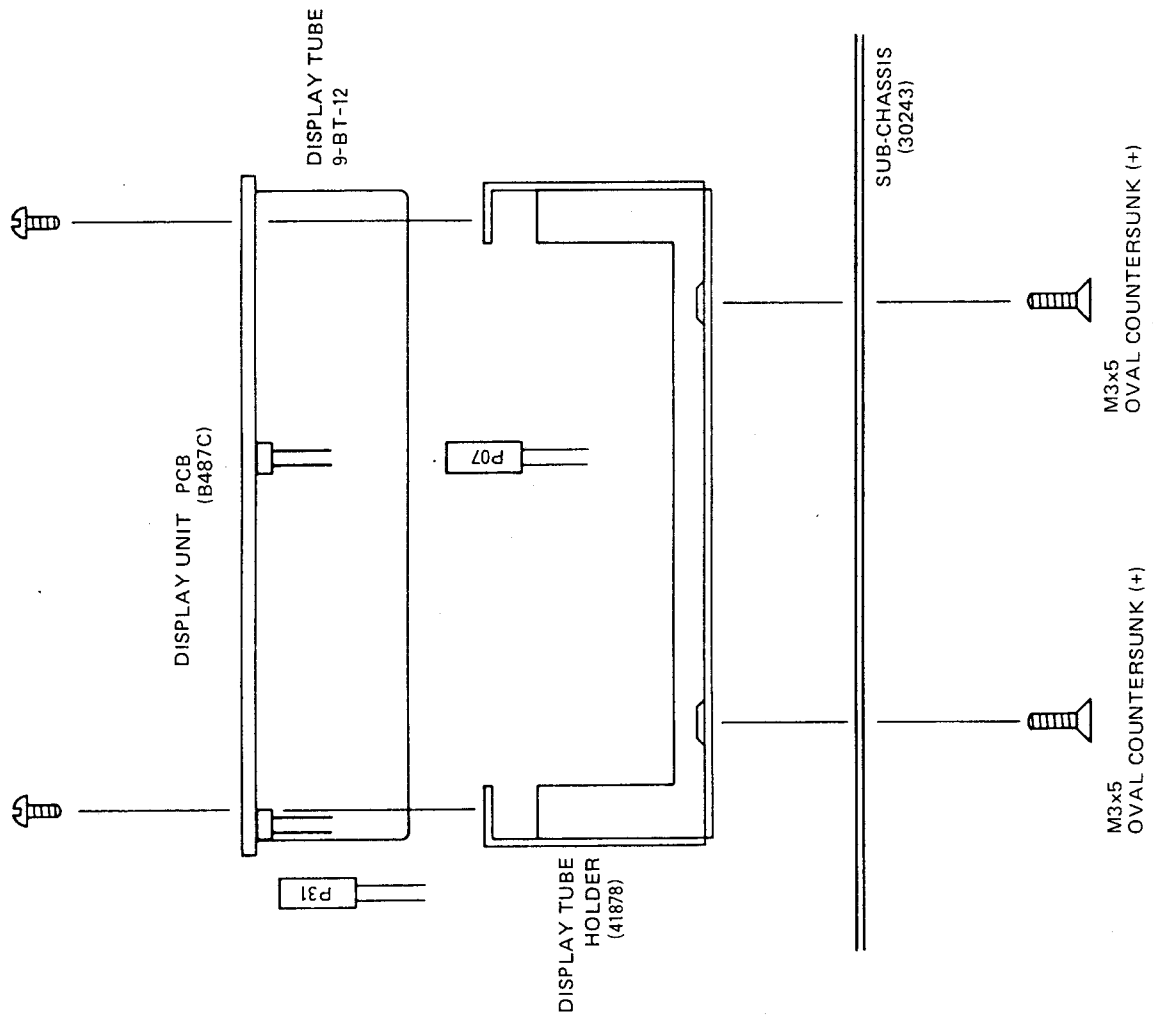

FILTER UNIT DISASSEMBLY

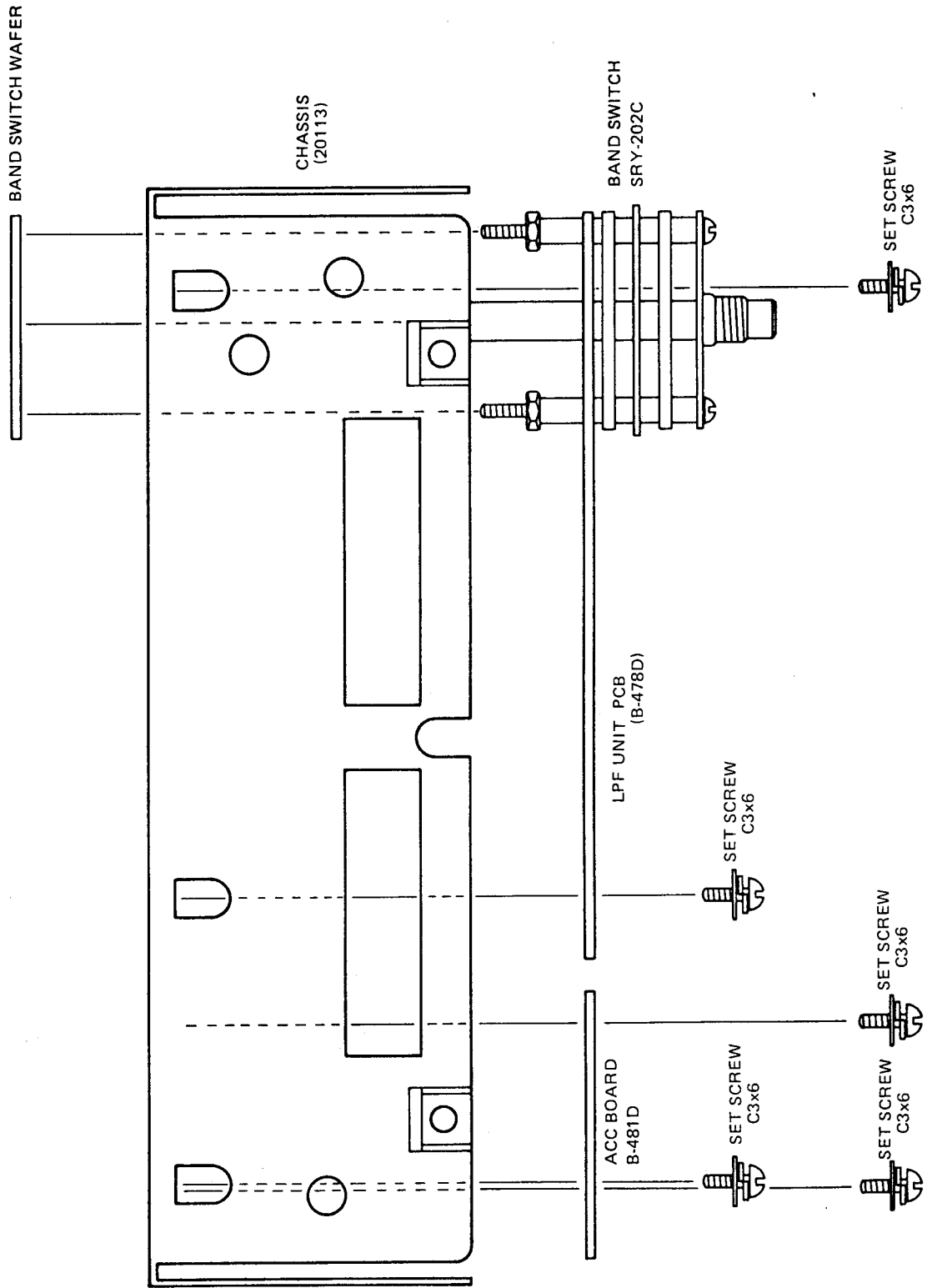

PARTS ON REAR PANEL

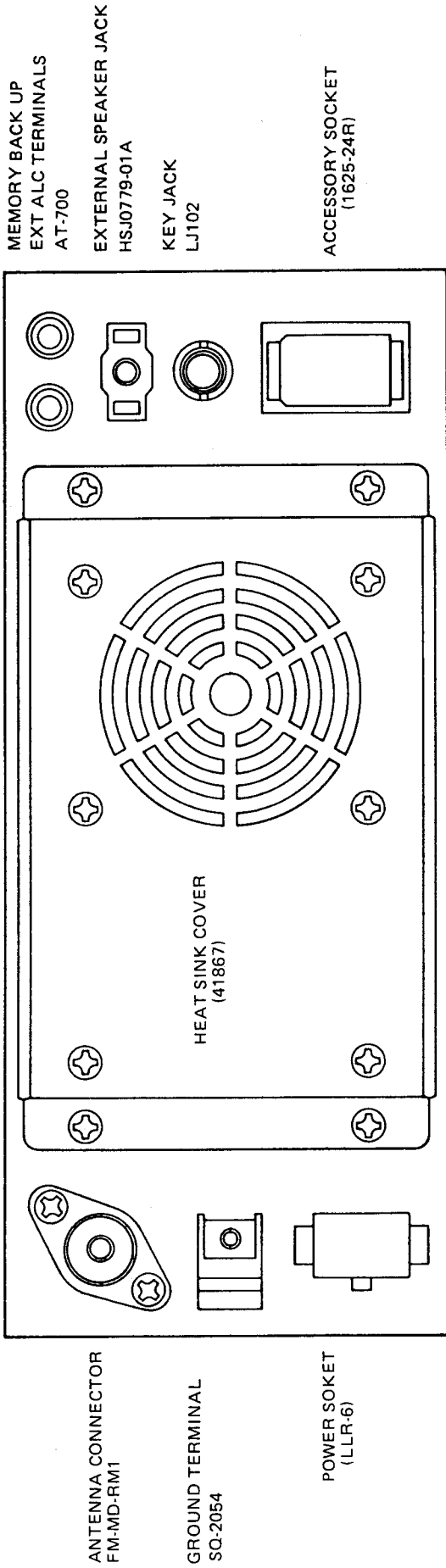

REAR PANEL
(30238)

REAR PANEL DISASSEMBLY

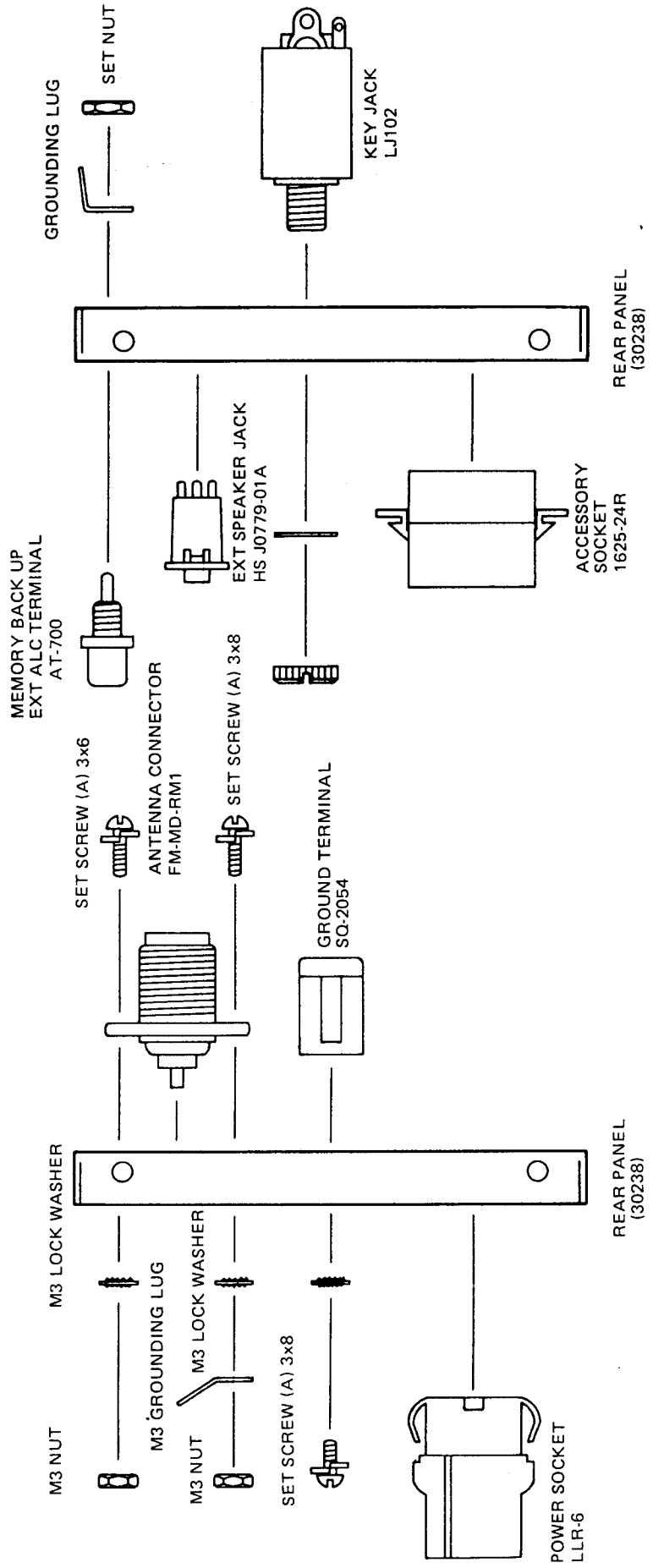

PA UNIT DISASSEMBLY

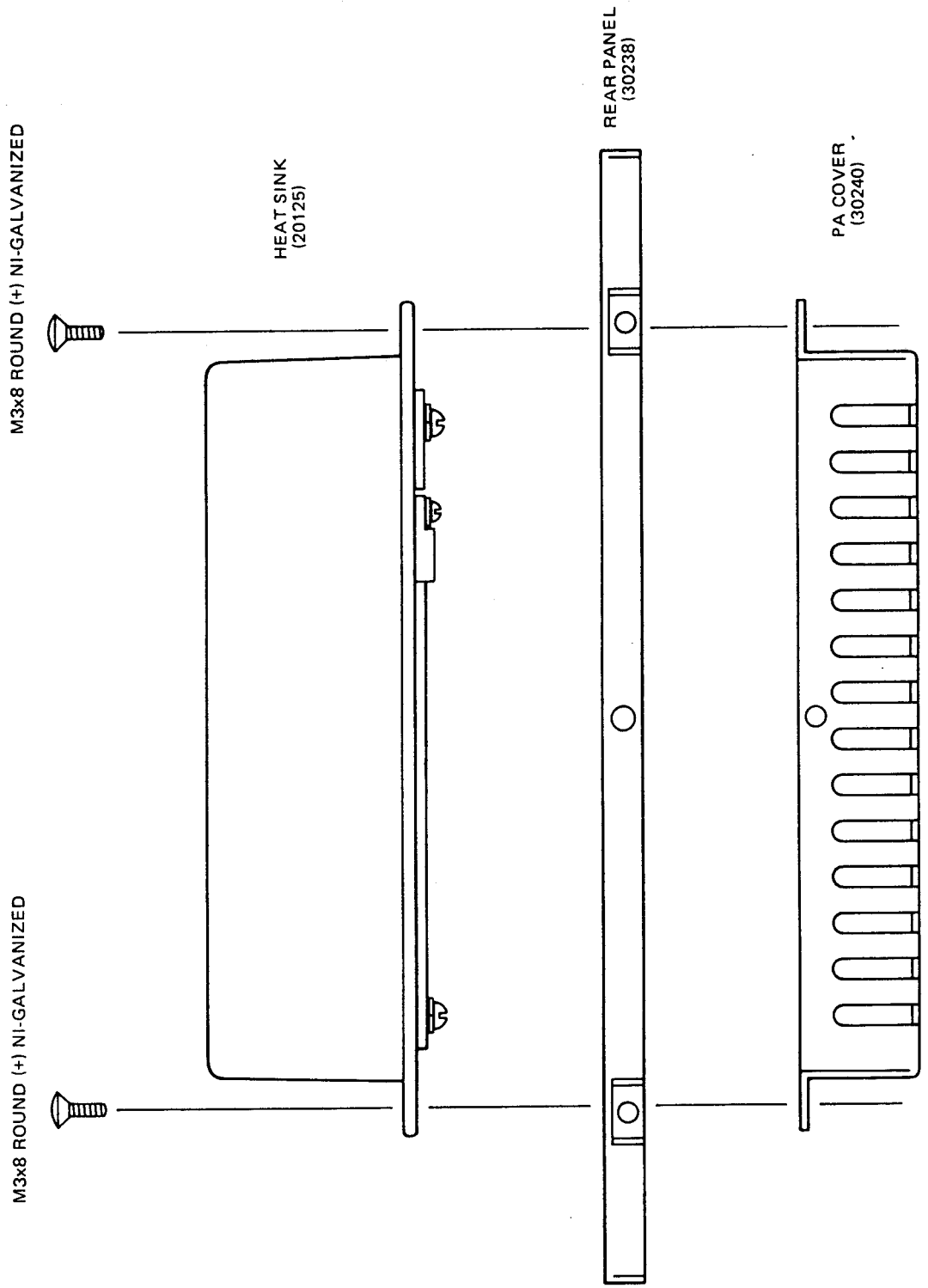

PA UNIT DISASSEMBLY

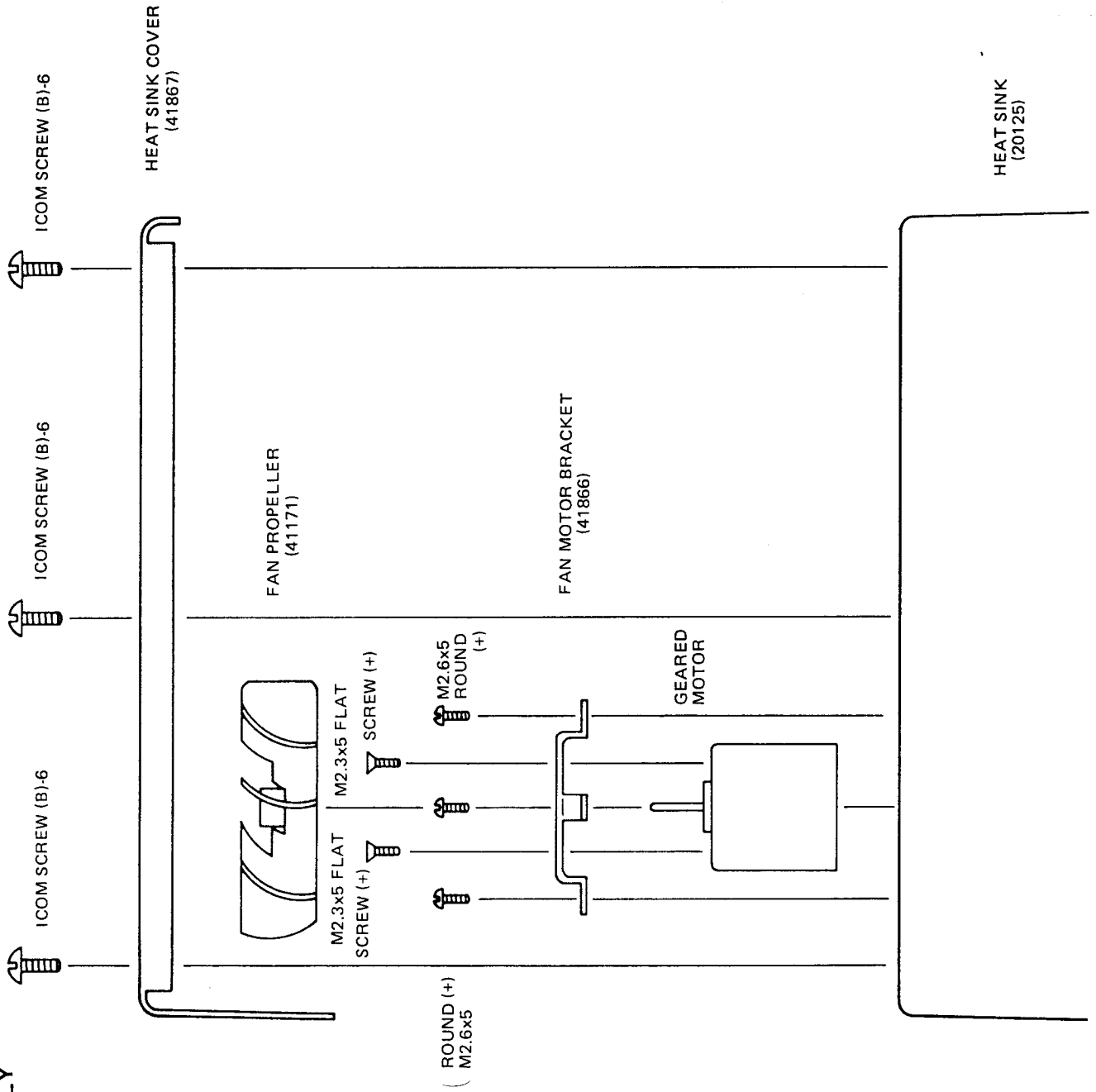

PA UNIT DISASSEMBLY

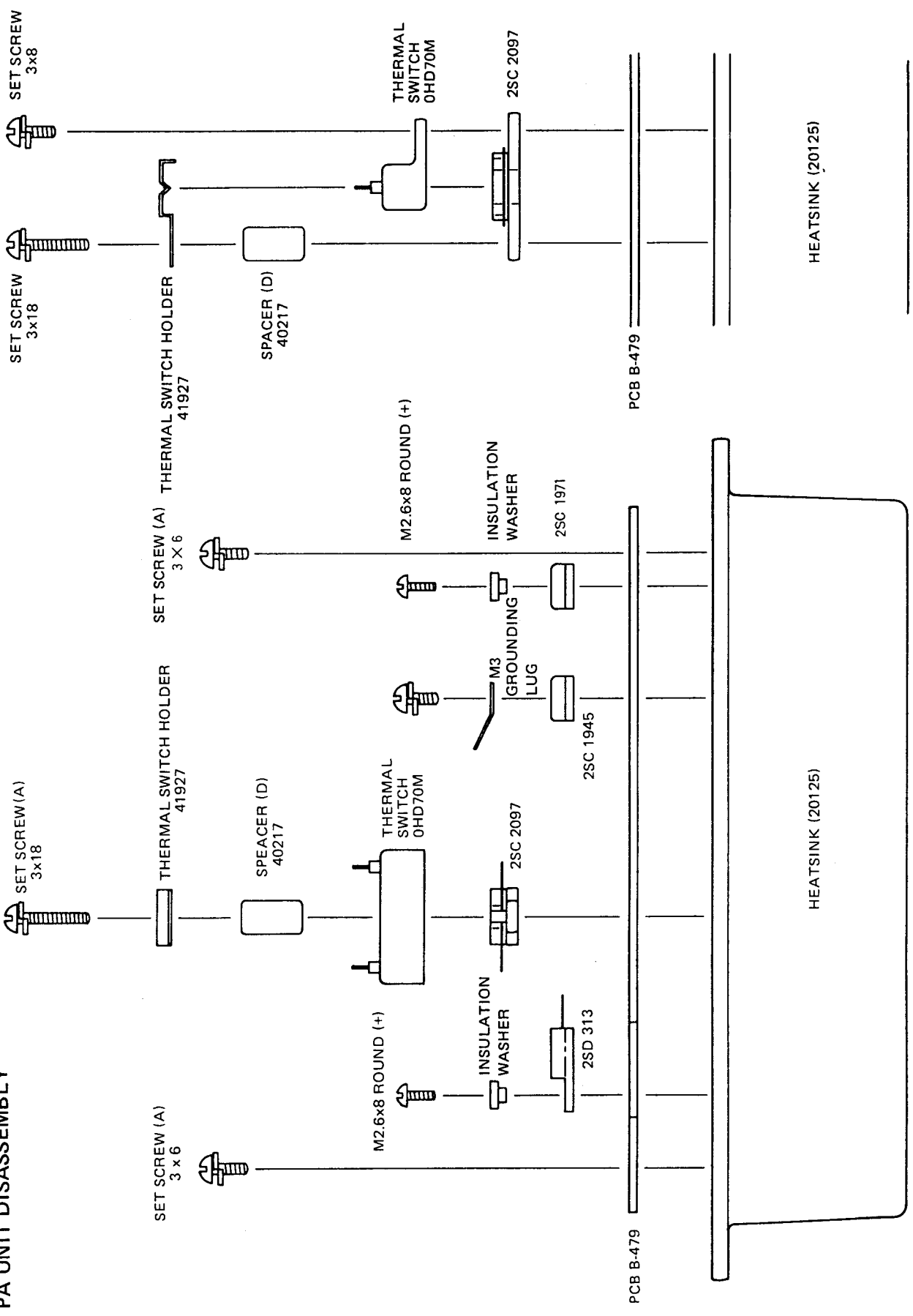

REAR PANEL WIRING

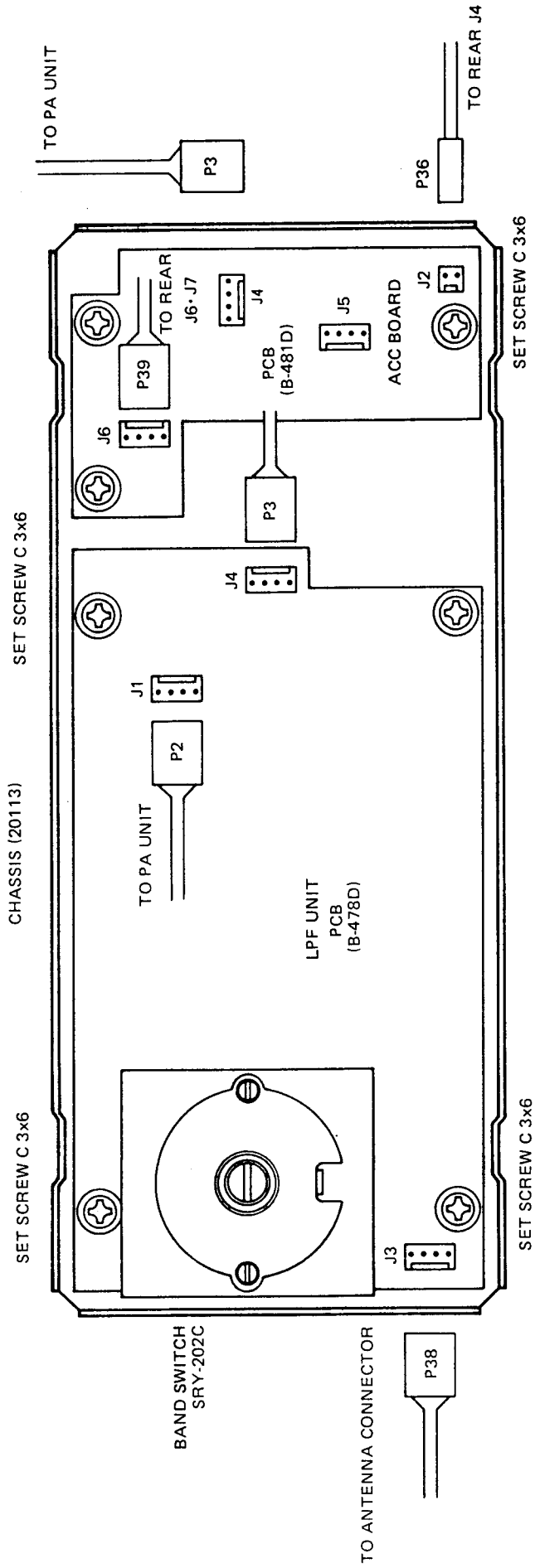

MAIN UNIT PC BOARD DISASSEMBLY

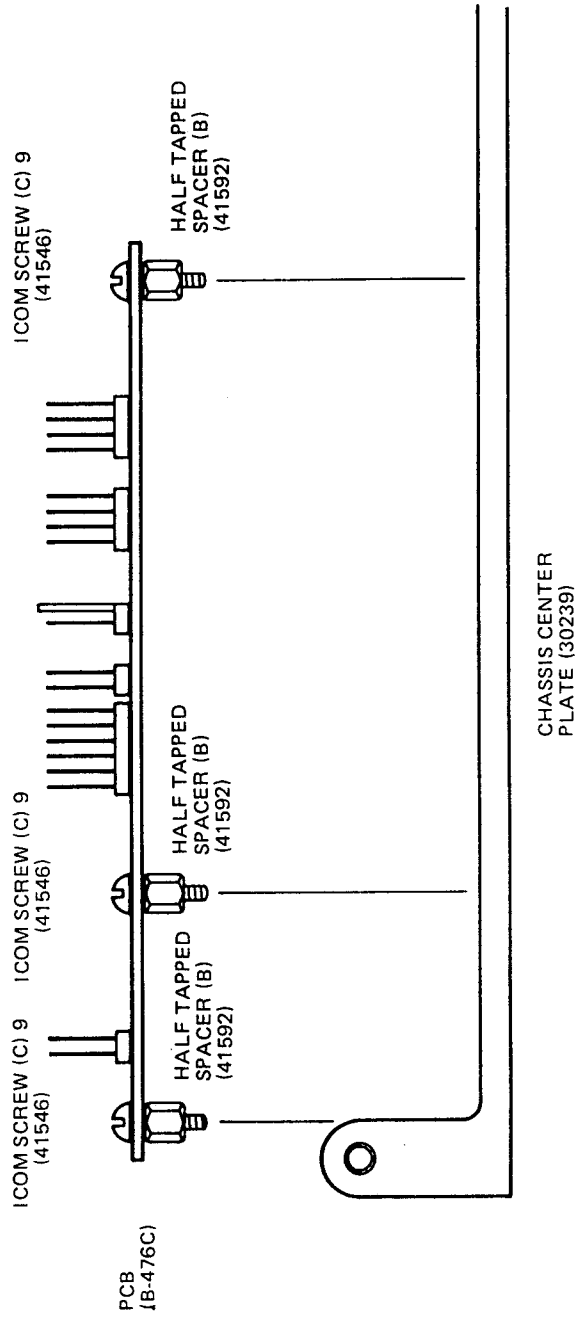

MAIN UNIT CONNECTOR LOCATION

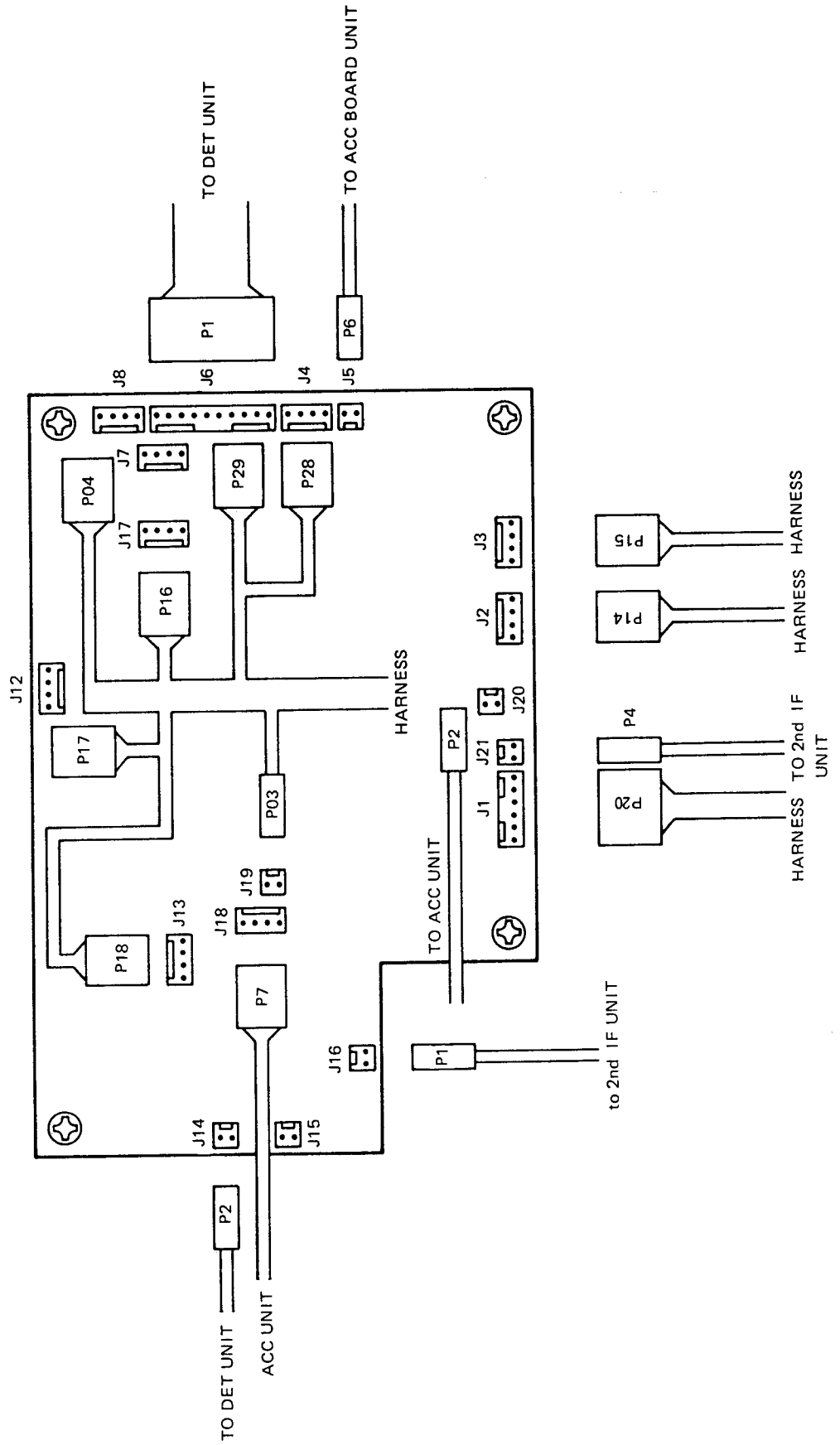

RF UNIT CONNECTOR LOCATION

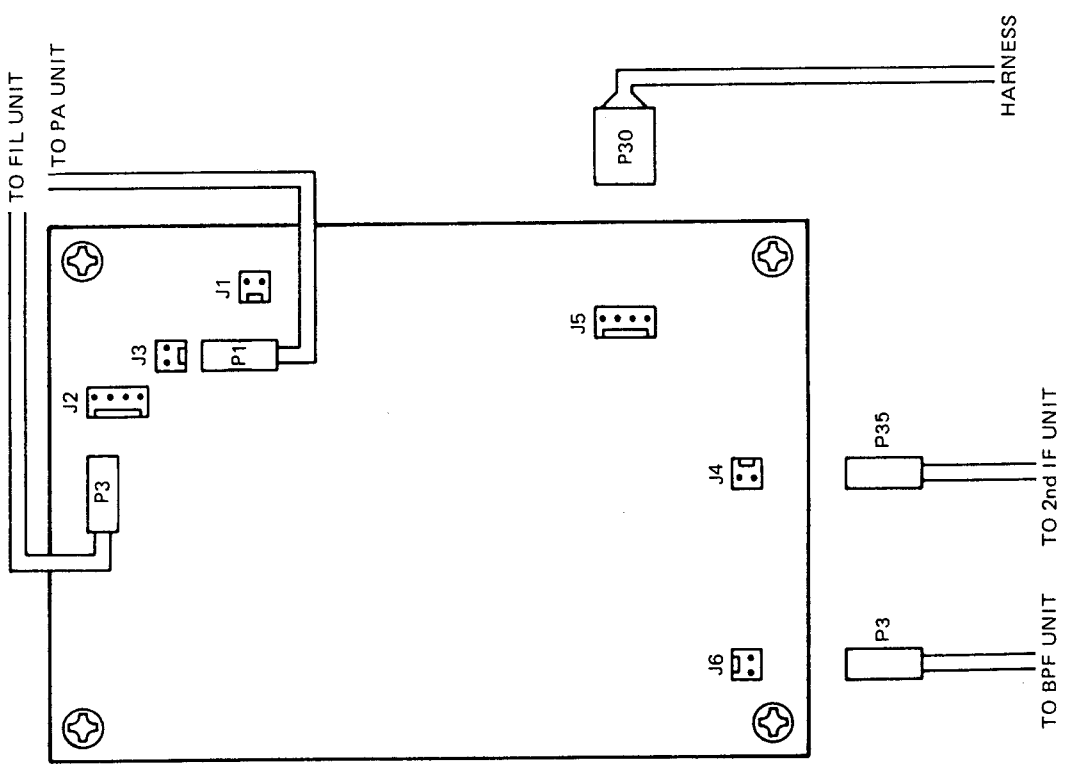

RF UNIT PC BOARD DISASSEMBLY

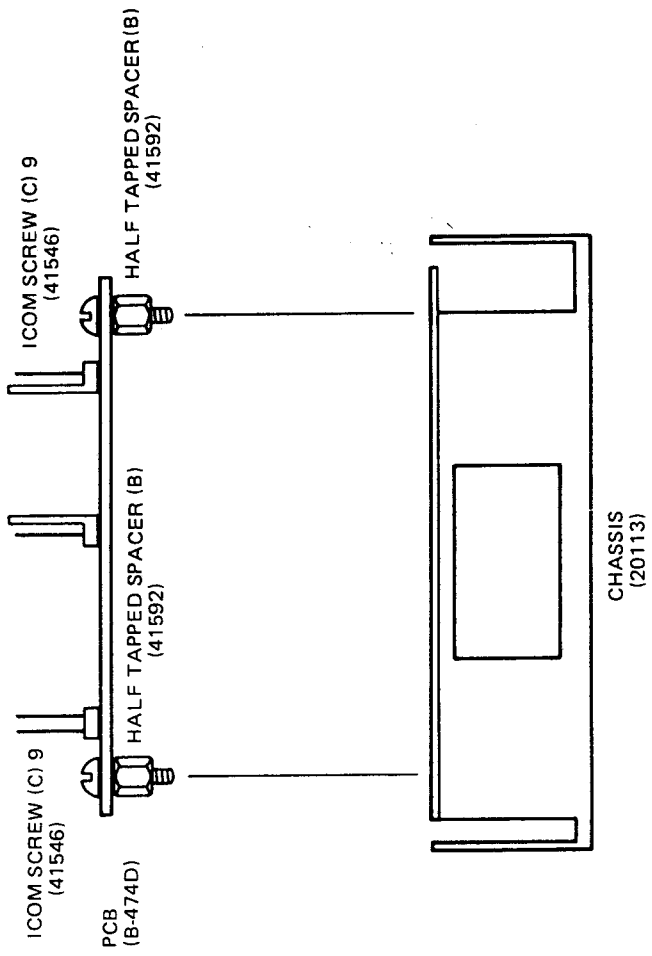

IF UNIT CONNECTOR LOCATION

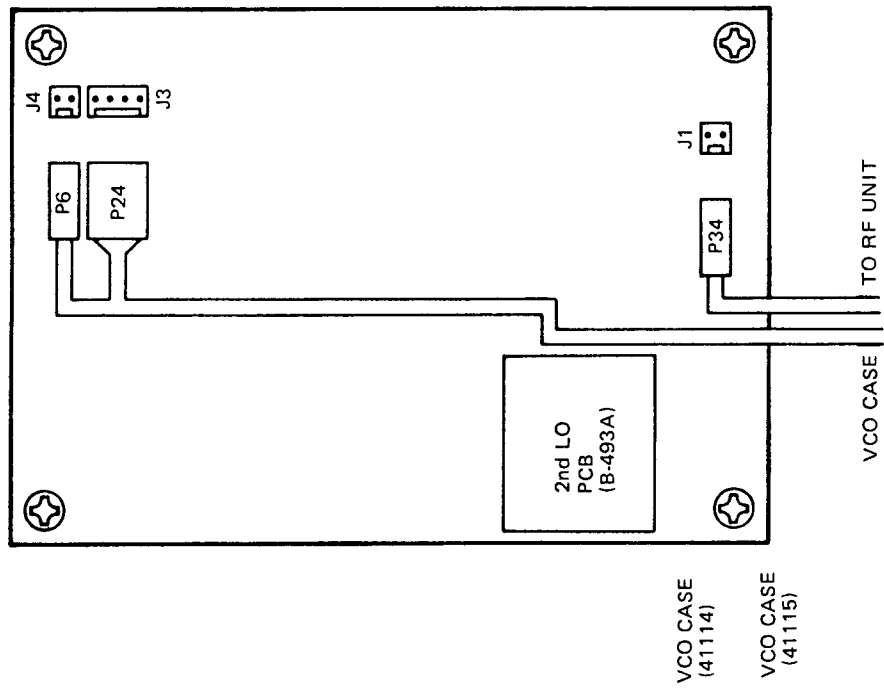

IF UNIT PC BOARD DISASSEMBLY

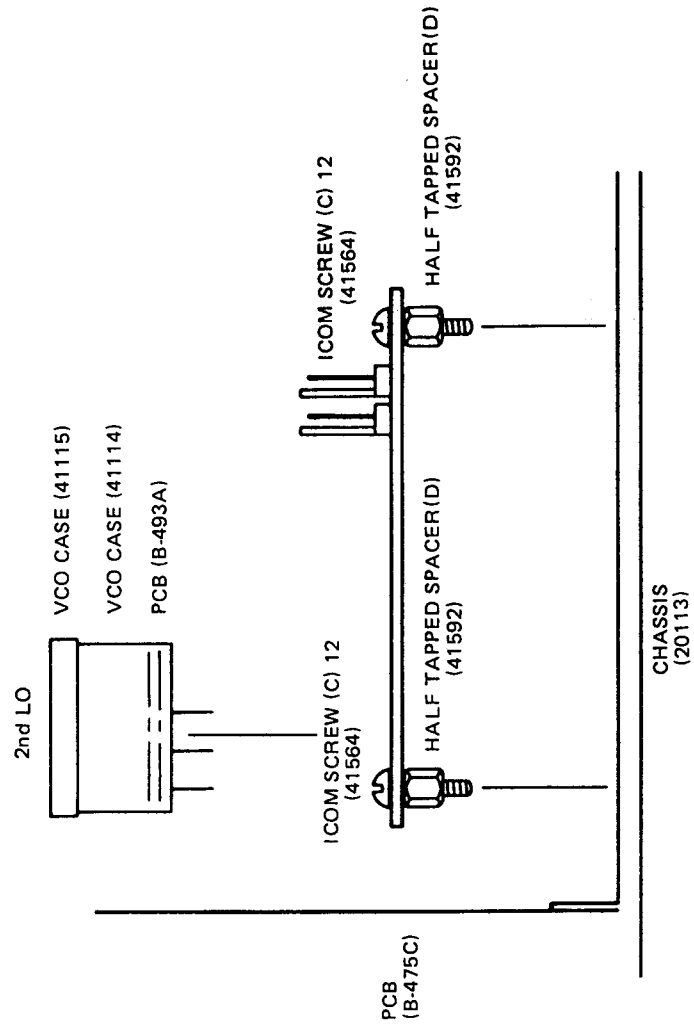

PREMIX UNIT CONNECTOR LOCATION

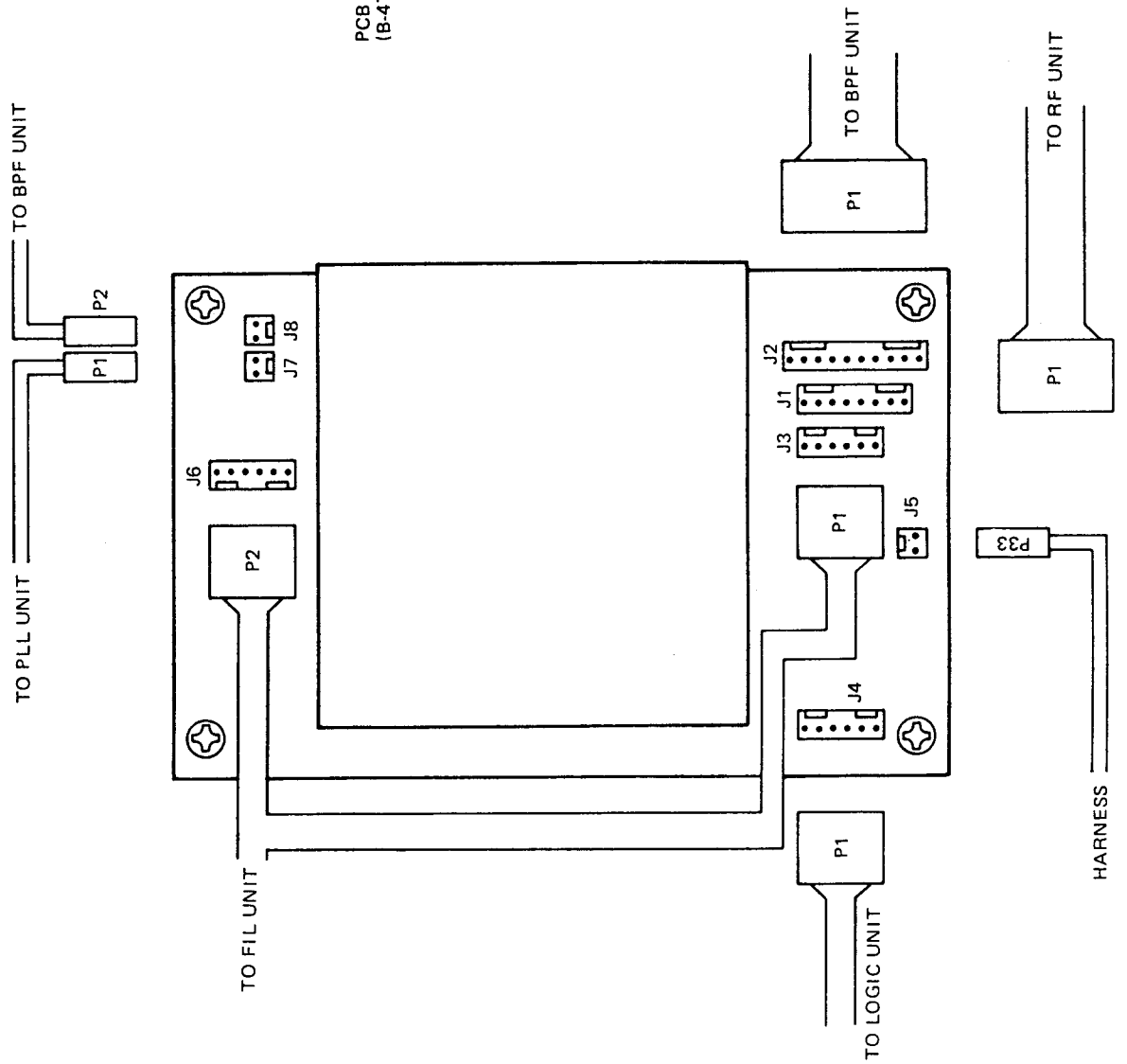

PREMIX UNIT DISASSEMBLY

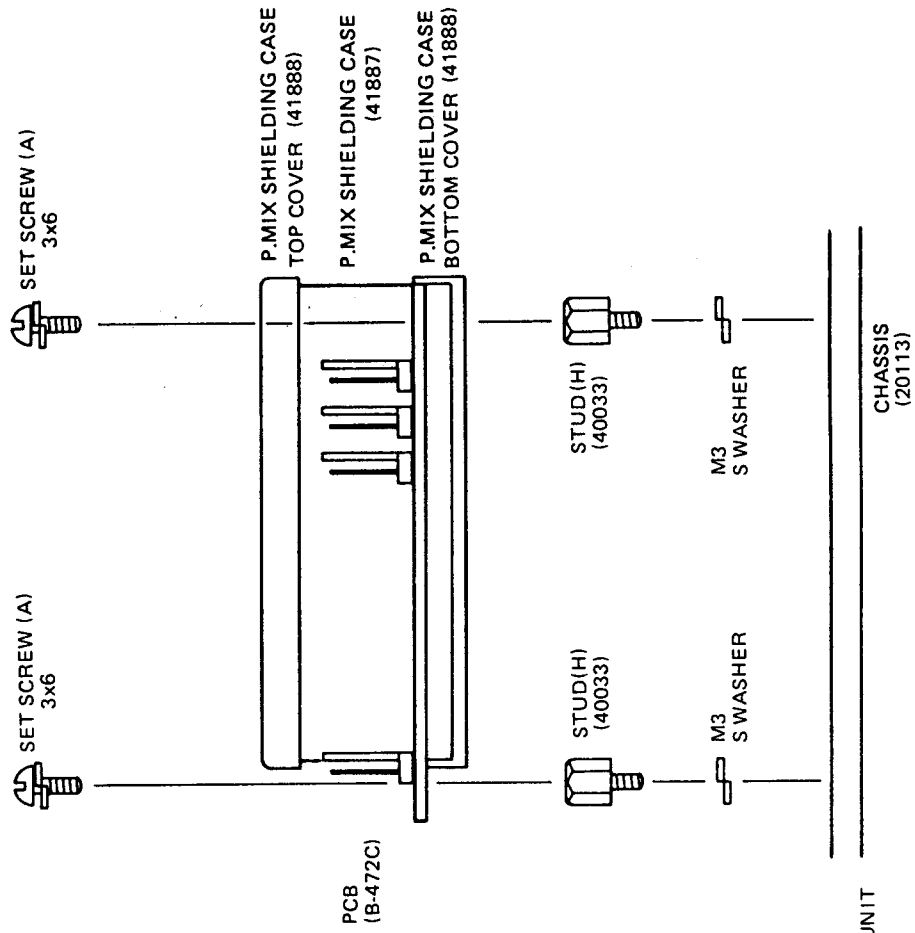

BPF UNIT CONNECTOR LOCATION

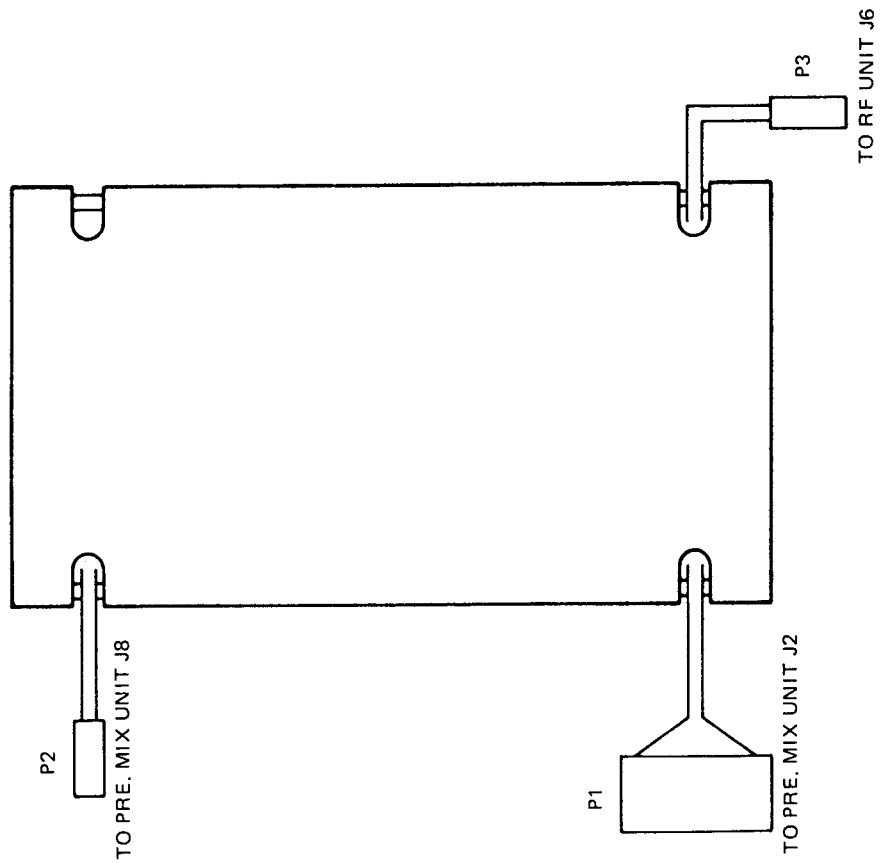

BPF UNIT DISASSEMBLY

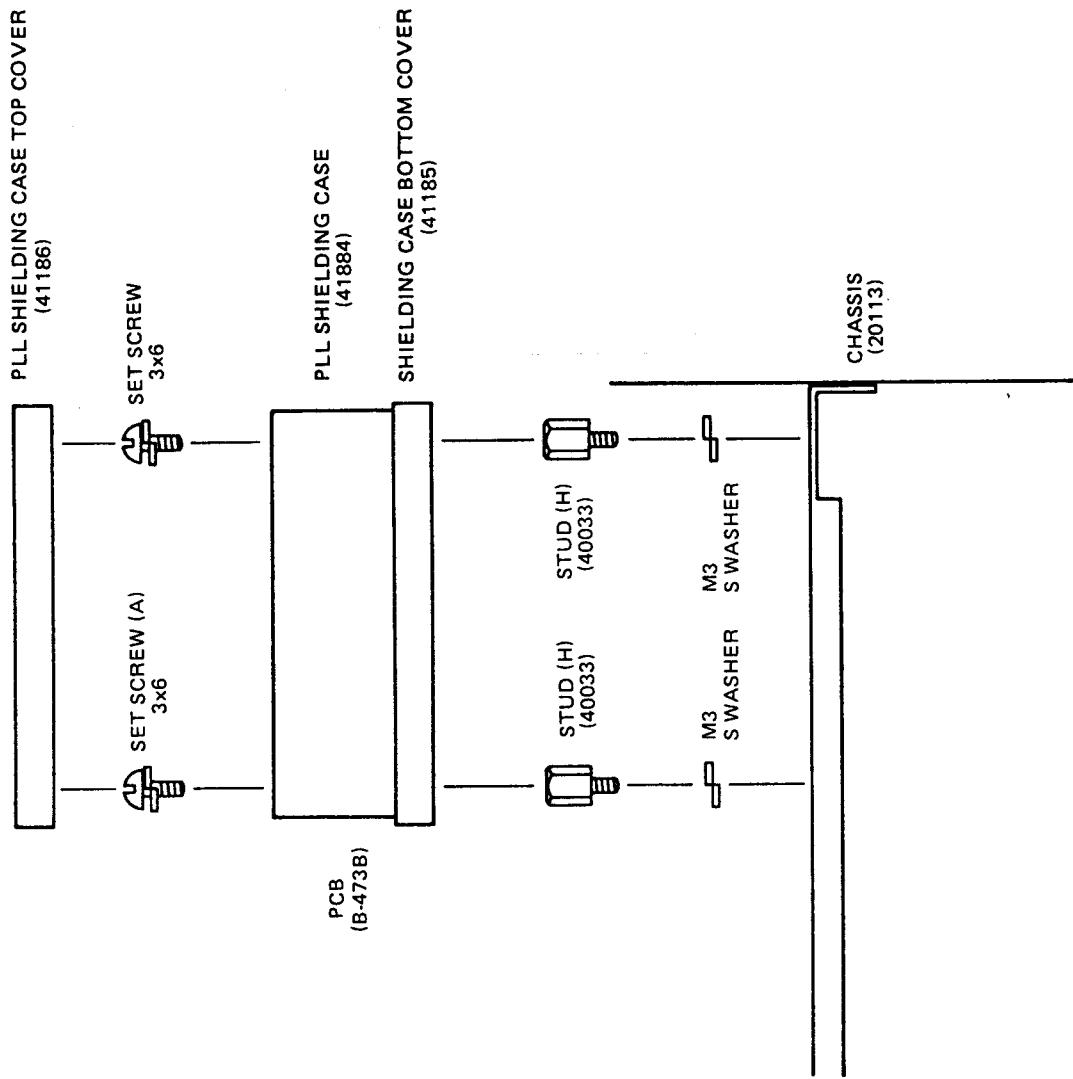

DET UNIT CONNECTOR LOCATION

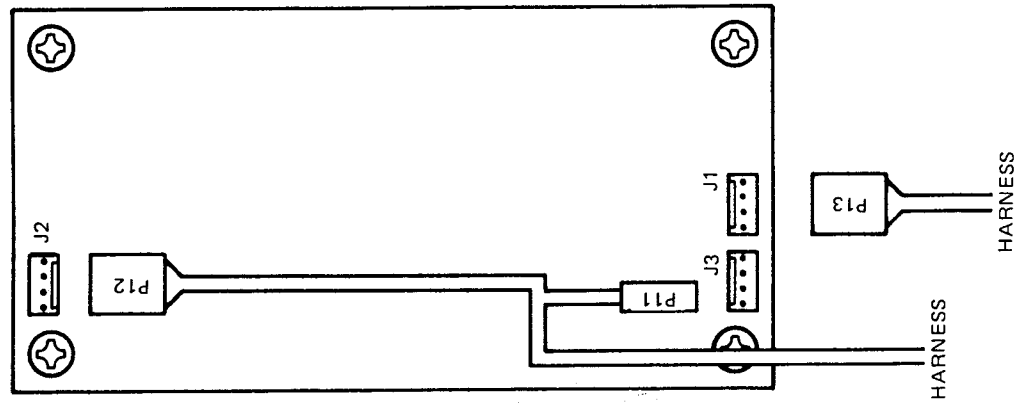

DET UNIT DISASSEMBLY

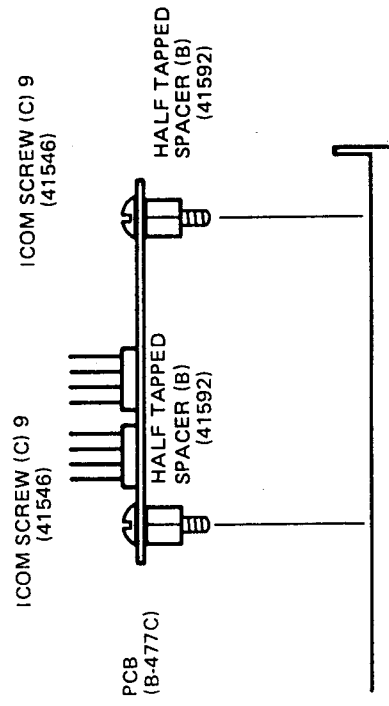

PLL UNIT CONNECTOR LOCATION

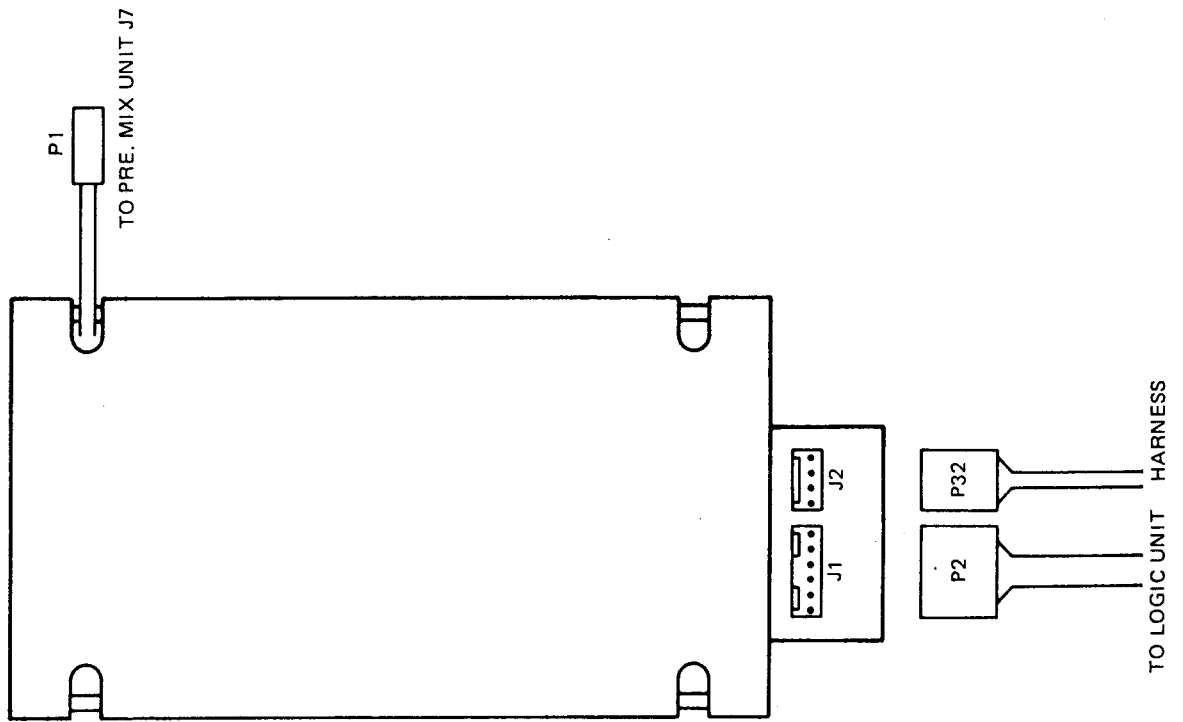

PLL UNIT DISASSEMBLY

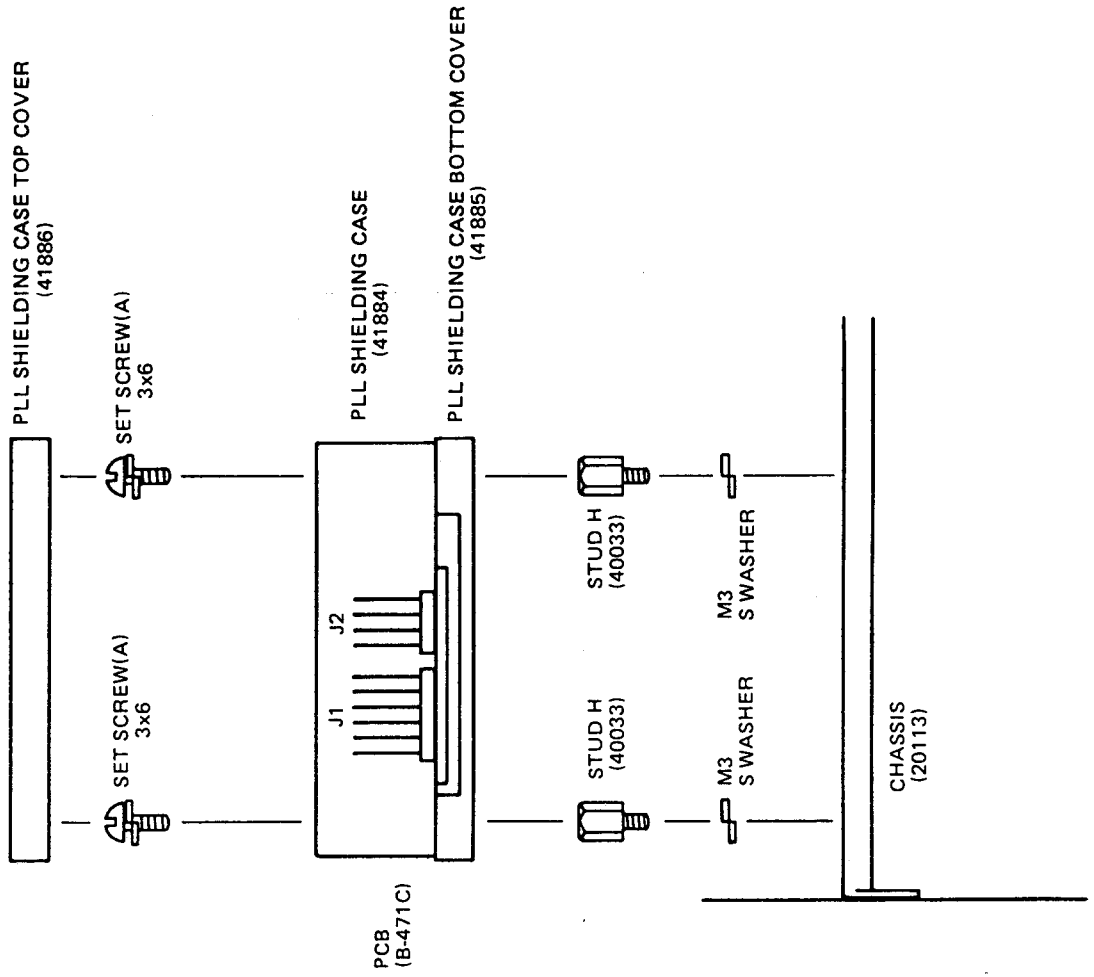

LOGIC UNIT CONNECTOR LOCATION

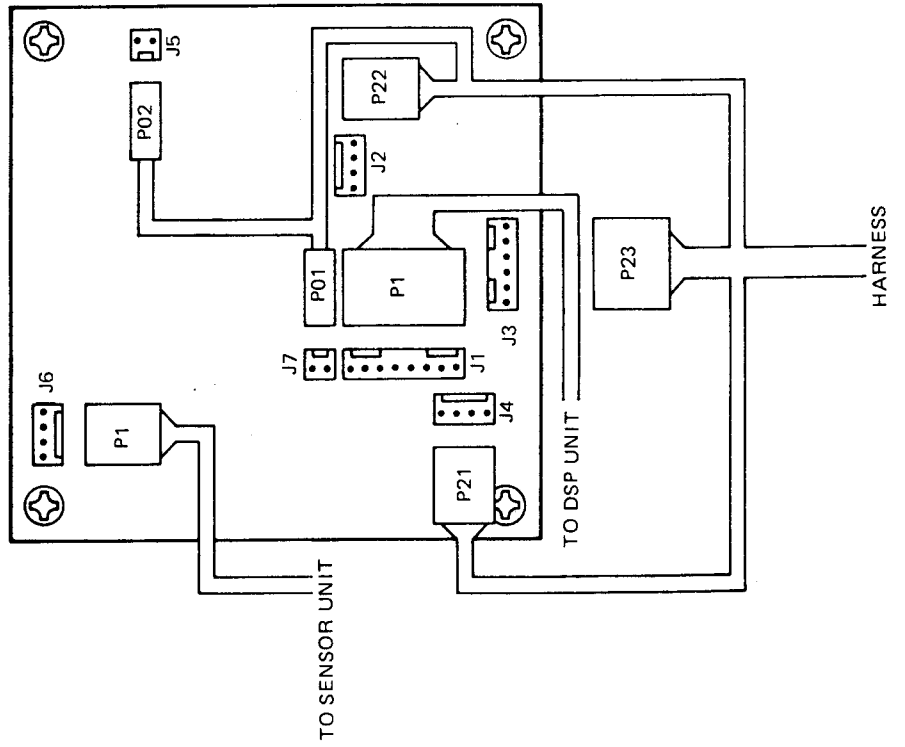

LOGIC UNIT DISASSEMBLY

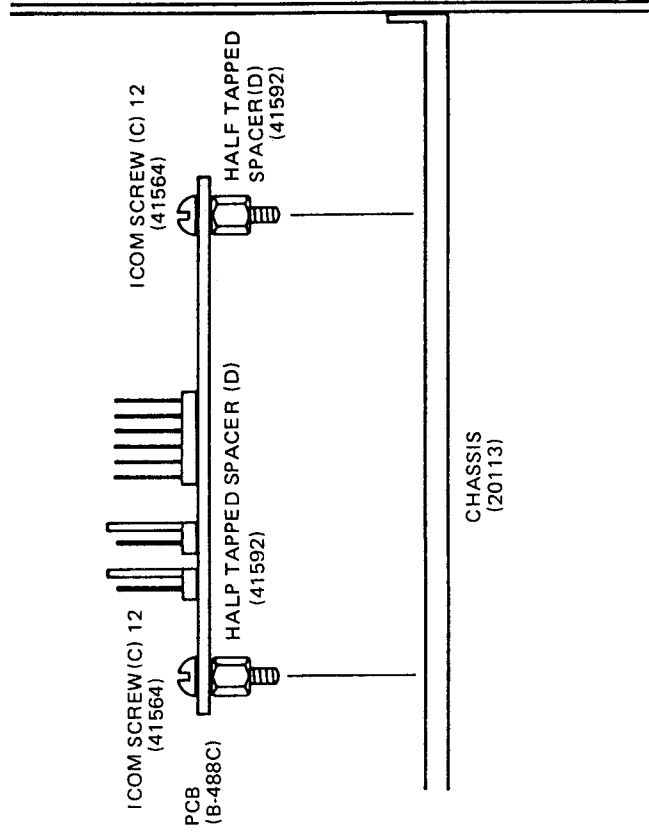

SECTION 8 MAINTENANCE AND ADJUSTMENT

8 - 1 MEASURING INSTRUMENTS REQUIRED FOR ADJUSTMENT

(1) FREQUENCY COUNTER	FREQUENCY RANGE ACCURACY SENSITIVITY	0.1 - 90MHz BETTER THAN ± 1 ppm 100mV or BETTER
(2) SIGNAL GENERATOR	FREQUENCY RANGE OUTPUT VOLTAGE 50K Ω /VOLT OR BETTER	0.1MHz - 40MHz -20 - 90dB (0dB = 1 μ V)
(3) MULTIMETER	MEASURING RANGE	10mV - 2V
(4) AC MILLIVOLTMETER	FREQUENCY RANGE	0.1 - 80MHz
(5) RF VOLTMETER	MEASURING RANGE	0.01 - 10V
(6) RF WATTMETER (Terminal Type)	MEASURING RANGE FREQUENCY RANGE IMPEDANCE SWR	20 - 200 Watts 1.8 - 30MHz 50 OHMS LESS THAN 1.1
(7) AF OSCILLATOR	OUTPUT FREQUENCY OUTPUT VOLTAGE	200 - 3000Hz 0 - 100mV
(8) OSCILLOSCOPE	FREQUENCY RANGE MEASURING RANGE	DC ~ 20MHz 0.01 - 10V
(9) NOISE GENERATOR	(Generates ignition-like noise containing harmonics beyond 30MHz.)	

NOTE: indicates an adjusting or instrument connecting point.
 indicates an instrument connecting point and its readings.
 These also are used in the board layout and schematic diagrams.

8 - 2 PLL ADJUSTMENT

Adjustment item	Adjusting procedures	Measuring location			Adjusting location		Instrument reading	Number of adjusting location
		Measuring instruments	UNIT	Terminal	UNIT	Parts		
LO adjustment	<ol style="list-style-type: none"> 1) Connect an RF voltmeter to R11 of the PLL unit. 2) Adjust L1 and L2 so that the level becomes maximum. 	RF voltmeter	PLL	R11	PLL	L1, L2	Maximum 100 mV or more.	101
Locked loop adjustment	<ol style="list-style-type: none"> 1) Connect the oscilloscope (for 20 MHz) to R26 of the PLL UNIT. 2) Adjust L3 and L4 so that the level becomes maximum. 	Oscilloscope	PLL	R26	PLL	L3, L4	Maximum 2.5 V p-p or more.	102
Lock adjustment	<ol style="list-style-type: none"> 1) Set the mode switch to AM or CW and display frequency at 13.900.0 MHz. 2) Connect the oscilloscope to R28 of the PLL UNIT. 3) Adjust the core of L8 so that the voltage is 4.8 to 5.2V. 4) Set the displayed frequency at 14.599.0 MHz. 5) Adjust the core of L8 so that the voltage is 1.8 to 2.2 V. 	Oscilloscope or DC voltmeter	PLL	R28	PLL	L8	4.8 ~ 5.2 V (13.900.0 MHz) 1.8 ~ 2.2 V (14.599.0 MHz)	103

Adjustment item	Adjusting procedures	Measuring location				Adjusting location		Instrument reading	Number of adjusting location
		Measuring instruments	UNIT	Terminal	UNIT	Parts			
PLL frequency adjustment	1) Set the mode switch to AM or CW and displayed frequency at 13.900.0 MHz. 2) Set the FREQUENCY SET R162, of MAIN UNIT to the center position. 3) Connect the frequency counter to R11 of the PLL UNIT. 4) With the RIT SW turned OFF, adjust the frequency at R2 of the RIT PCB to 41.000.0 MHz. 5) With the RIT SW turned ON and RIT knob placed at the center position adjust the frequency at R2 of the RIT PCB to 41.000.0 MHz. 6) Connect the frequency counter to P1 of PLL. 7) Adjust C31 of PLL UNIT so that the frequency becomes 13.200.0 MHz.								
		Frequency counter	PLL	R11		(R162)	(Center)		
					RIT			41.000.0 MHz	104
					RIT			41.000.0 MHz	105
					PLL	P1			
					PLL		C31	13.200.0 MHz	106
PRE MIX frequency adjustment	1) MODE: AM or CW 2) Connect the frequency counter to P3 of B.P.F. UNIT.	Frequency counter	B.P.F.	P3		PRE. MIX			

Adjustment item	Adjusting procedures	Measuring location			Adjusting location		Instrument reading	Number of adjusting location																																			
		Measuring instruments	UNIT	Terminal	UNIT	Parts																																					
PRE MIX frequency adjustment (continued)	<p>3) With the displayed frequency sequentially varied, adjust each coil at the PRE MIX UNIT to the following frequencies.</p> <table border="1"> <thead> <tr> <th>Displayed frequency</th> <th>Adjusting coil</th> <th>Frequency</th> </tr> </thead> <tbody> <tr><td>3.600.0 MHz</td><td>L1</td><td>43.331.50 MHz</td></tr> <tr><td>7.100.0</td><td>L2</td><td>46.831.50</td></tr> <tr><td>10.100.0</td><td>L3</td><td>49.831.50</td></tr> <tr><td>14.100.0</td><td>L4</td><td>53.831.50</td></tr> <tr><td>18.100.0</td><td>L5</td><td>57.831.50</td></tr> <tr><td>21.100.0</td><td>L6</td><td>60.831.50</td></tr> <tr><td>24.600.0</td><td>L7</td><td>64.331.50</td></tr> <tr><td>28.100.0</td><td>L8</td><td>67.831.50</td></tr> <tr><td>28.600.0</td><td>L9</td><td>68.331.50</td></tr> <tr><td>29.100.0</td><td>L10</td><td>68.831.50</td></tr> <tr><td>29.600.0</td><td>L11</td><td>69.331.50</td></tr> </tbody> </table>	Displayed frequency	Adjusting coil	Frequency	3.600.0 MHz	L1	43.331.50 MHz	7.100.0	L2	46.831.50	10.100.0	L3	49.831.50	14.100.0	L4	53.831.50	18.100.0	L5	57.831.50	21.100.0	L6	60.831.50	24.600.0	L7	64.331.50	28.100.0	L8	67.831.50	28.600.0	L9	68.331.50	29.100.0	L10	68.831.50	29.600.0	L11	69.331.50				L1 L2 L3 L4 L5 L6 L7 L8 L9 L10 L11	43.331.50 MHz 46.831.50 49.831.50 53.831.50 57.831.50 60.831.50 64.331.50 67.831.50 68.331.50 68.831.50 69.331.50	107
Displayed frequency	Adjusting coil	Frequency																																									
3.600.0 MHz	L1	43.331.50 MHz																																									
7.100.0	L2	46.831.50																																									
10.100.0	L3	49.831.50																																									
14.100.0	L4	53.831.50																																									
18.100.0	L5	57.831.50																																									
21.100.0	L6	60.831.50																																									
24.600.0	L7	64.331.50																																									
28.100.0	L8	67.831.50																																									
28.600.0	L9	68.331.50																																									
29.100.0	L10	68.831.50																																									
29.600.0	L11	69.331.50																																									
BFO adjustment	<ol style="list-style-type: none"> 1) Mode: USB (receiving) 2) Connect the frequency counter to R46 of DET PCB. 3) Shunt the cathode of D4 to ground using a clip. 4) Set the frequency to 9.012.90 MHz with C40 of DET PCB. 5) Transmitting in the CW mode, adjust L2 of DET PCB so that the frequency becomes 9.011.50 MHz. 	Frequency counter	DET	R46 D4 ground			9.012.90 MHz 9.011.50 MHz	108 109																																			

Adjustment item	Adjusting procedures	Measuring location			Adjusting location		Instrument reading	Number of adjusting location		
		Measuring instruments	UNIT	Terminal	UNIT	Parts				
BFO adjustment (continued)	<p>6) Returning to the receiving in the CW mode, adjust L3 for 9.010.70 MHz.</p> <p>7) Receiving in the LSB mode, adjust L4 for 9.010.10 MHz.</p>				DET	L3	9.010.7 MHz	110		
					DET	L4	9.010.10 MHz	111		
IF SHIFT adjustment	<p>1) Connect the frequency counter to D4 of MAIN UNIT.</p> <p>2) Shift the IF SHIFT knob fully left.</p> <p>3) Adjust L11 of MAIN UNIT for 9.468.30 MHz. (For the old type, adjust for 9.468.00 MHz.)</p> <p>4) Return the knob to a center.</p> <p>5) Adjust R3 of REG PCB for 9.466.5 MHz.</p> <p>6) With the knob shifted fully right confirm that the frequency becomes 9.464.7 MHz \pm 200 Hz. (For the old type, 9.465.0 MHz \pm 200 Hz.)</p> <p>7) Adjust R66 of MAIN UNIT for 9.466.5 MHz during transmission.</p>	Frequency counter	MAIN	D4	MAIN	L11	9.468.30 MHz	112		
							REG	R3	Confirm 9.466.50 MHz	113
							MAIN	R66	9.464.70 MHz \pm 200 Hz	114
							MAIN		9.466.50 MHz	

Adjustment item	Adjusting procedures	Measuring location			Adjusting location		Instrument reading	Number of adjusting location
		Measuring instruments	UNIT	Terminal	UNIT	Parts		
2nd LO adjustment	<ol style="list-style-type: none"> 1) Set mode switch to AM and frequency to 14.100.0 MHz. 2) Connect the frequency counter to R5 of RF UNIT and unplug J3. 3) Place in the transmitting condition with RF POWER control set to maximum. 4) Adjust L1 of 2nd LO PCB for 14.100.0 MHz. 5) Select 100 Hz steps by pushing the 100 Hz tuning rate switch. 6) Adjust the tuning control so that displayed frequency is 14.099.9 MHz. 7) Adjust R93 of MAIN UNIT for 14.099.9 MHz. 	Frequency counter	RF	R5 (J3) ⑩ ⑪	2nd LO L1	MAIN R93	14.100.0 MHz 14.099.9 MHz	115 116

4

FREQUENCY ADJUST PARTS LOCATION

PLL UNIT

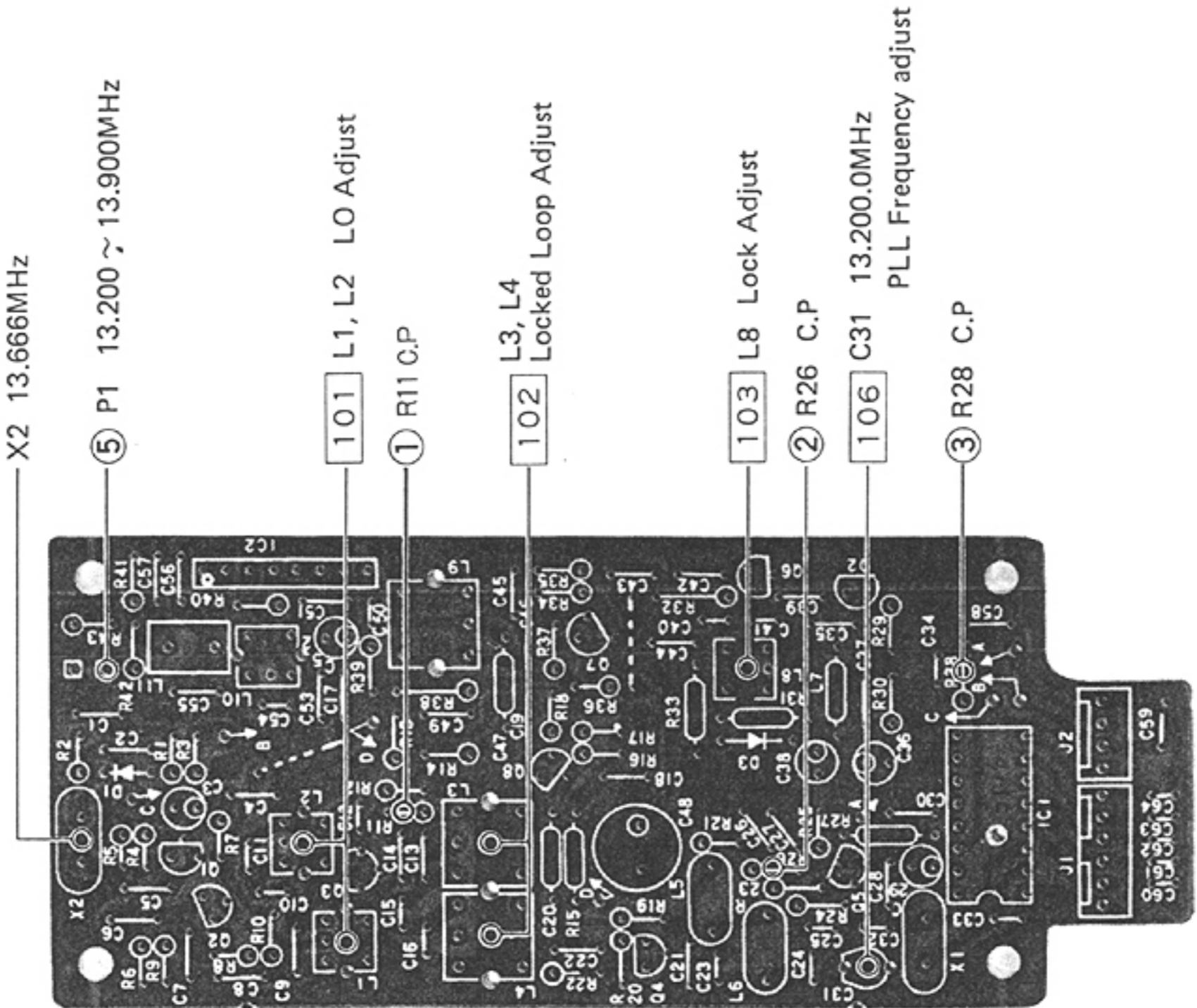

PREMIX UNIT

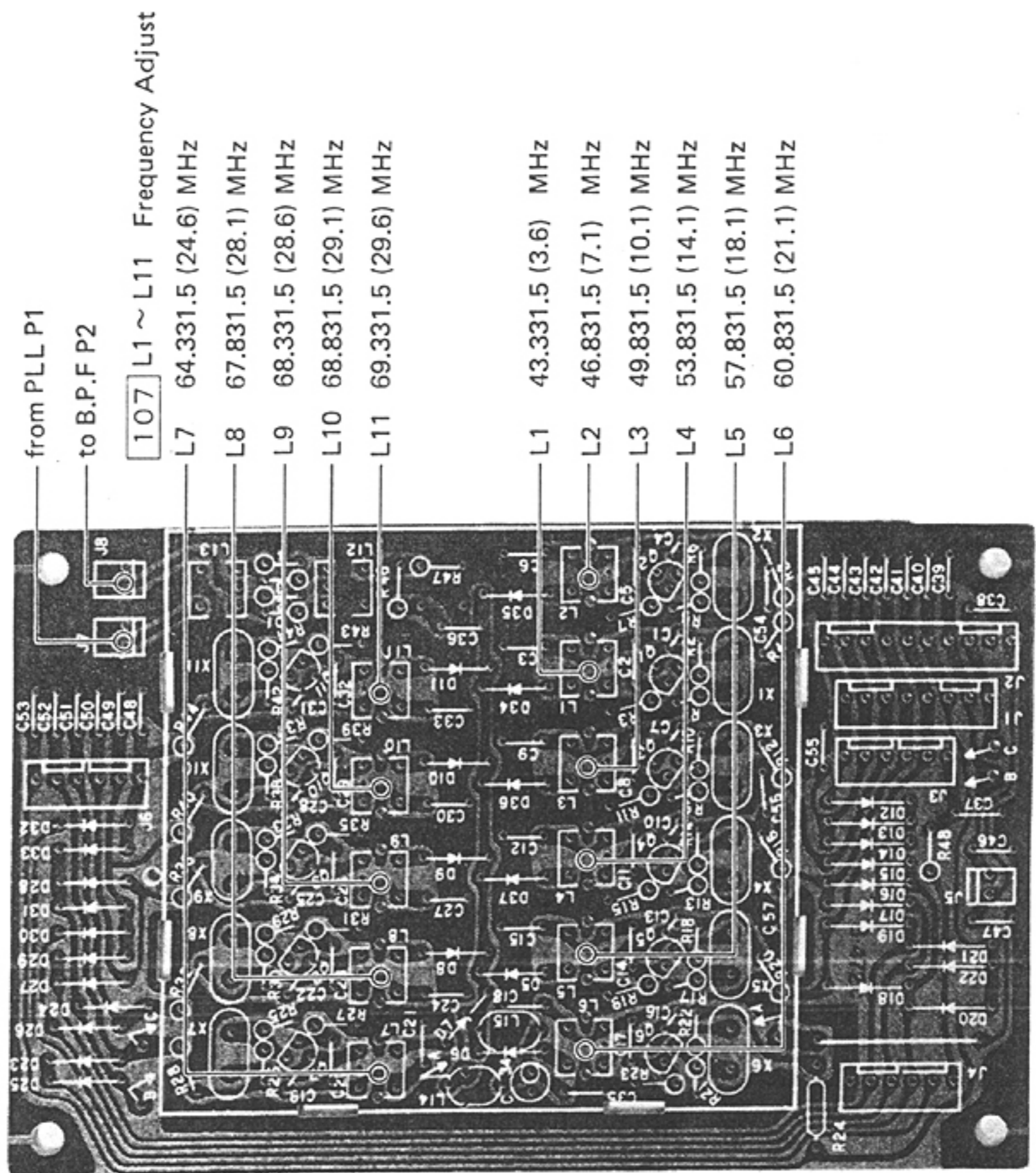

DET UNIT

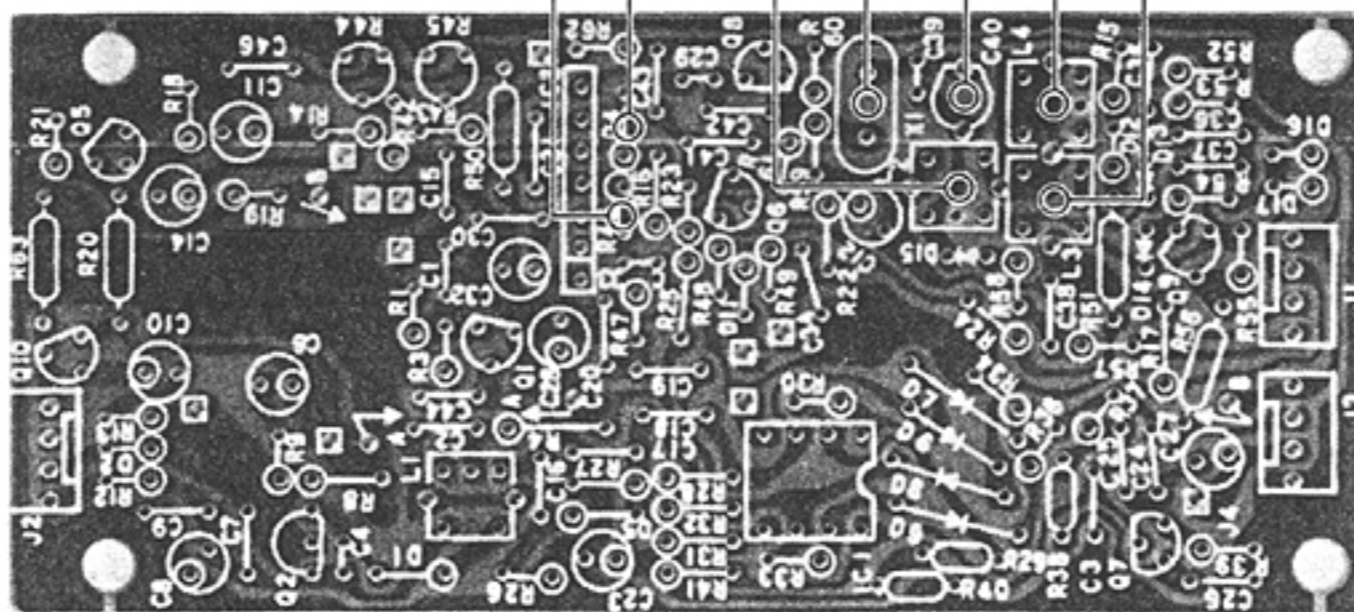

2ND IF UNIT

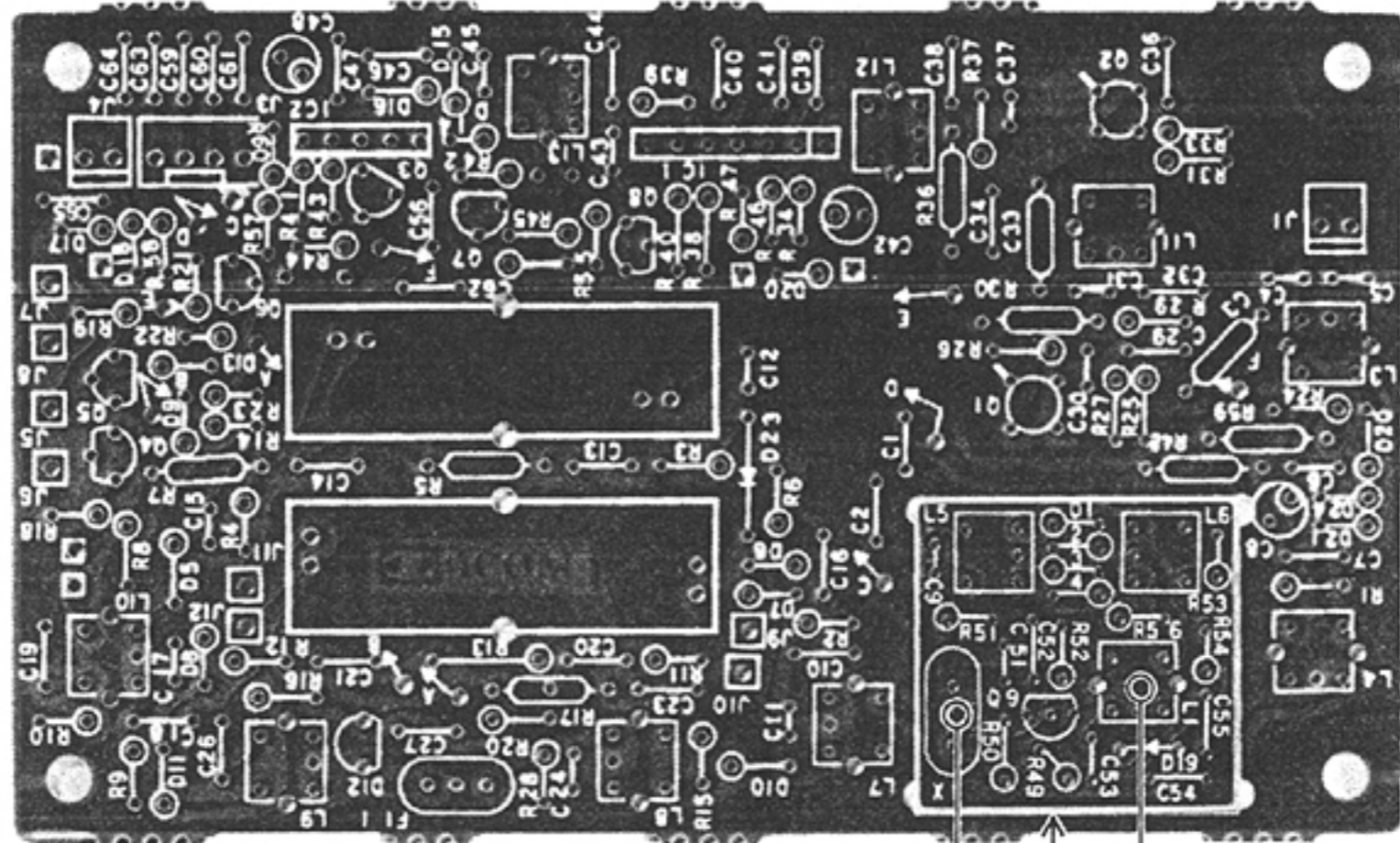

MAIN UNIT

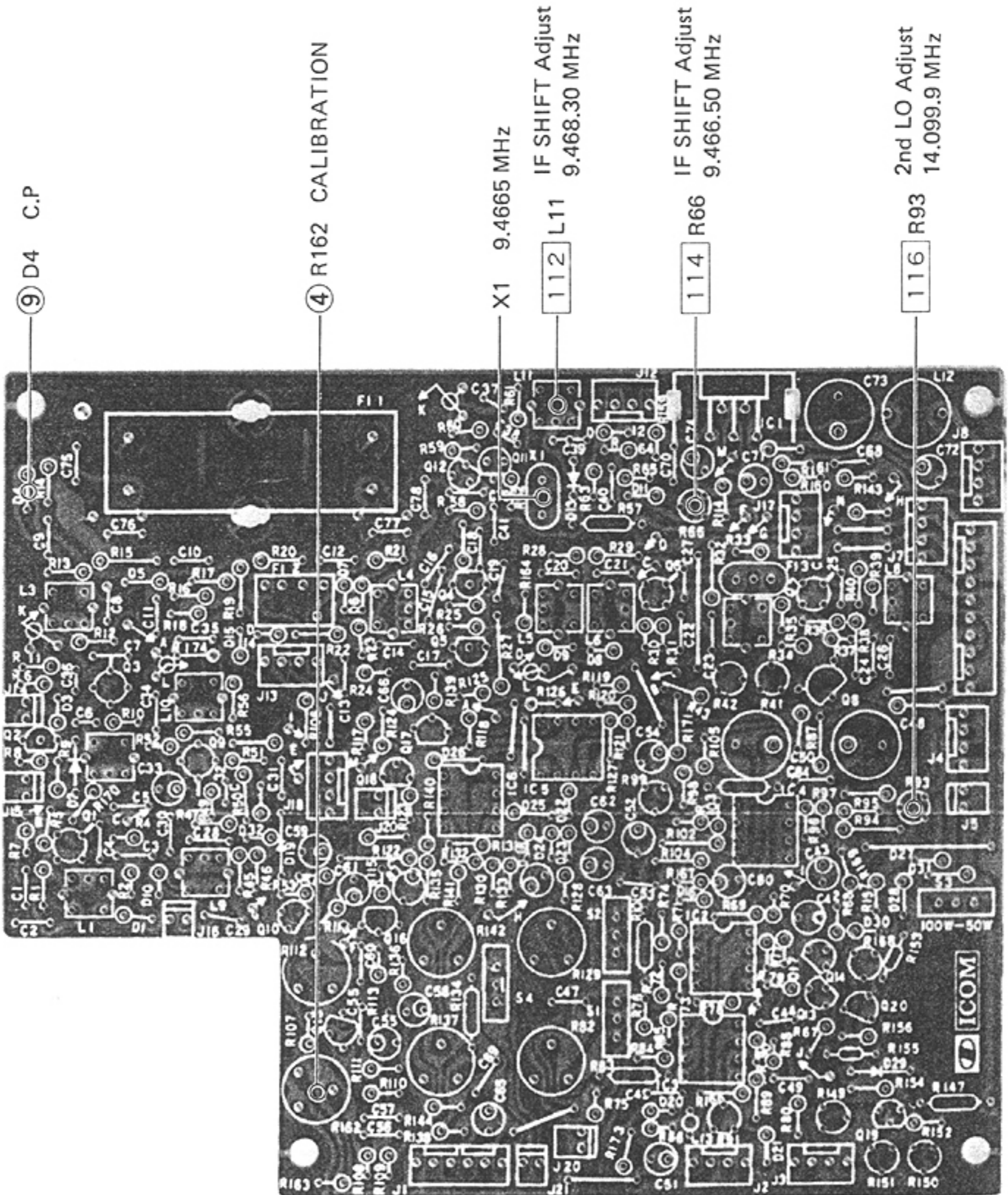

REG UNIT

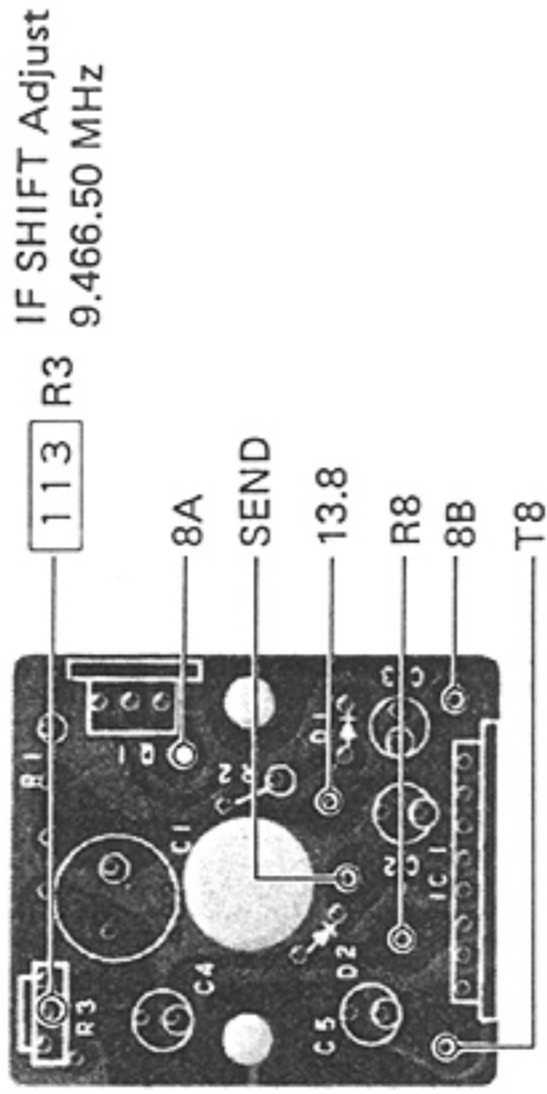

RIT UNIT

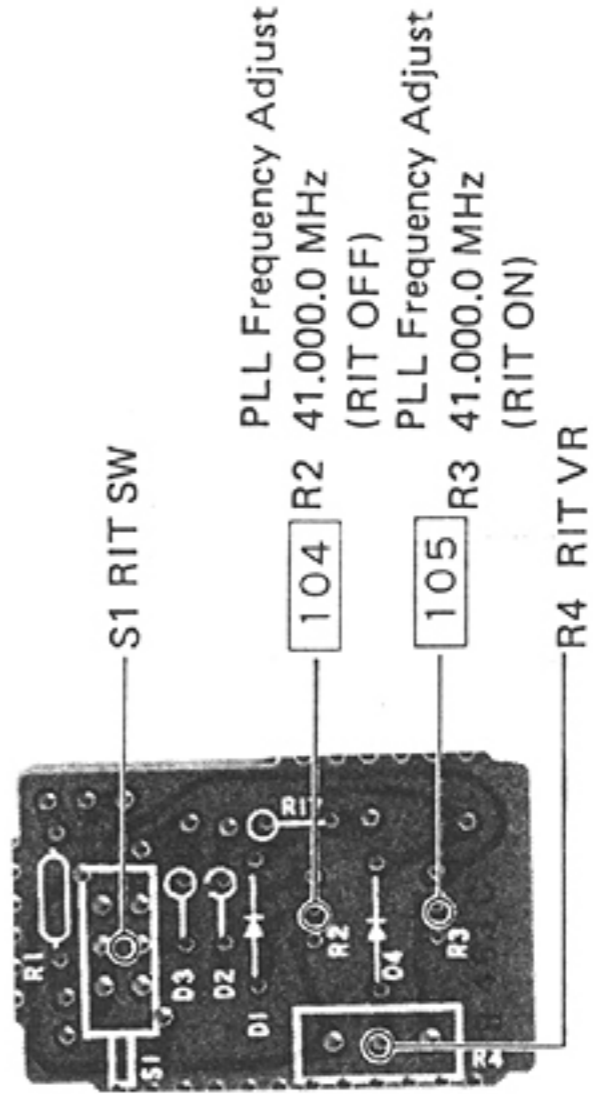

RF UNIT

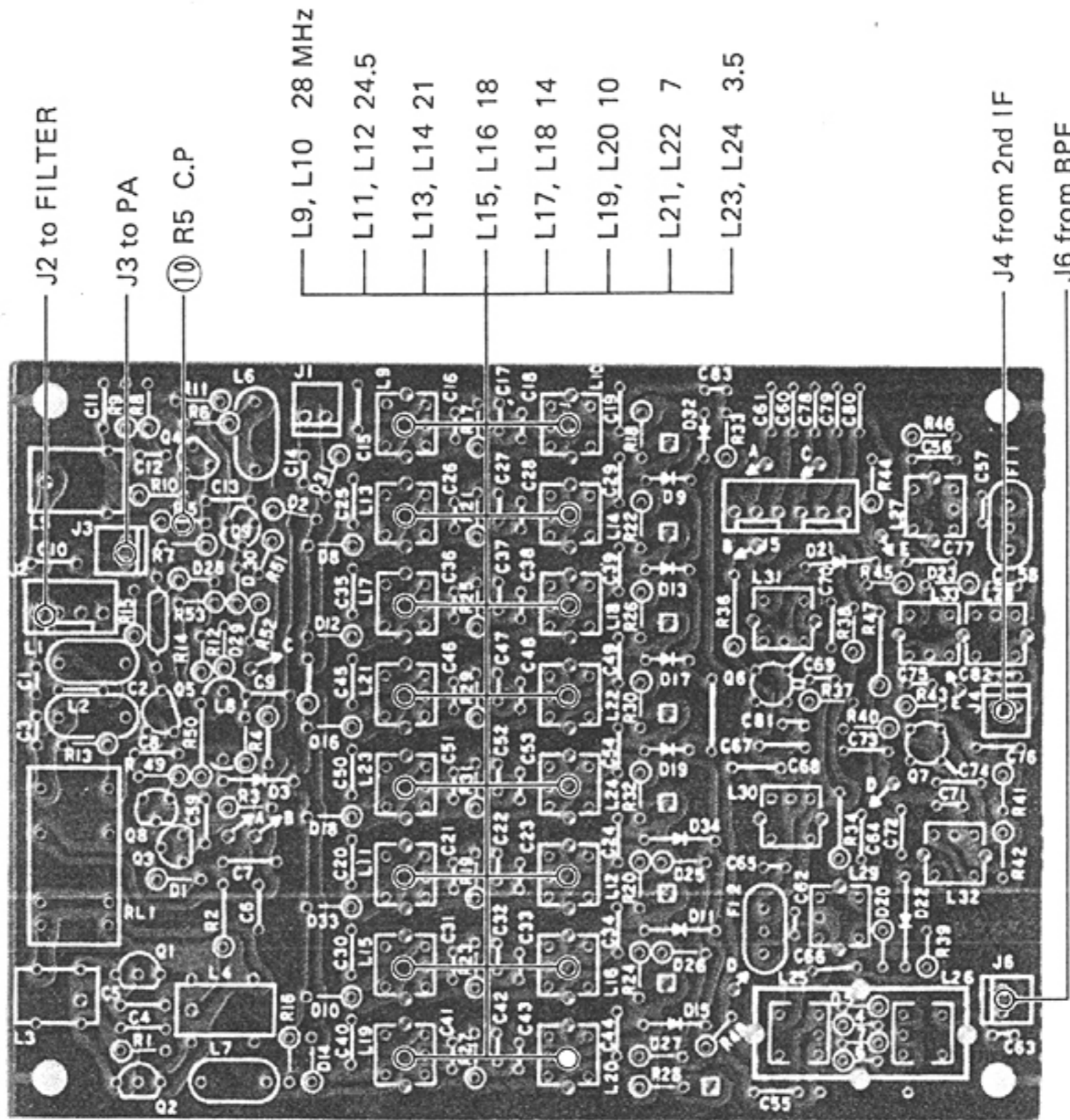

B.P.F. UNIT

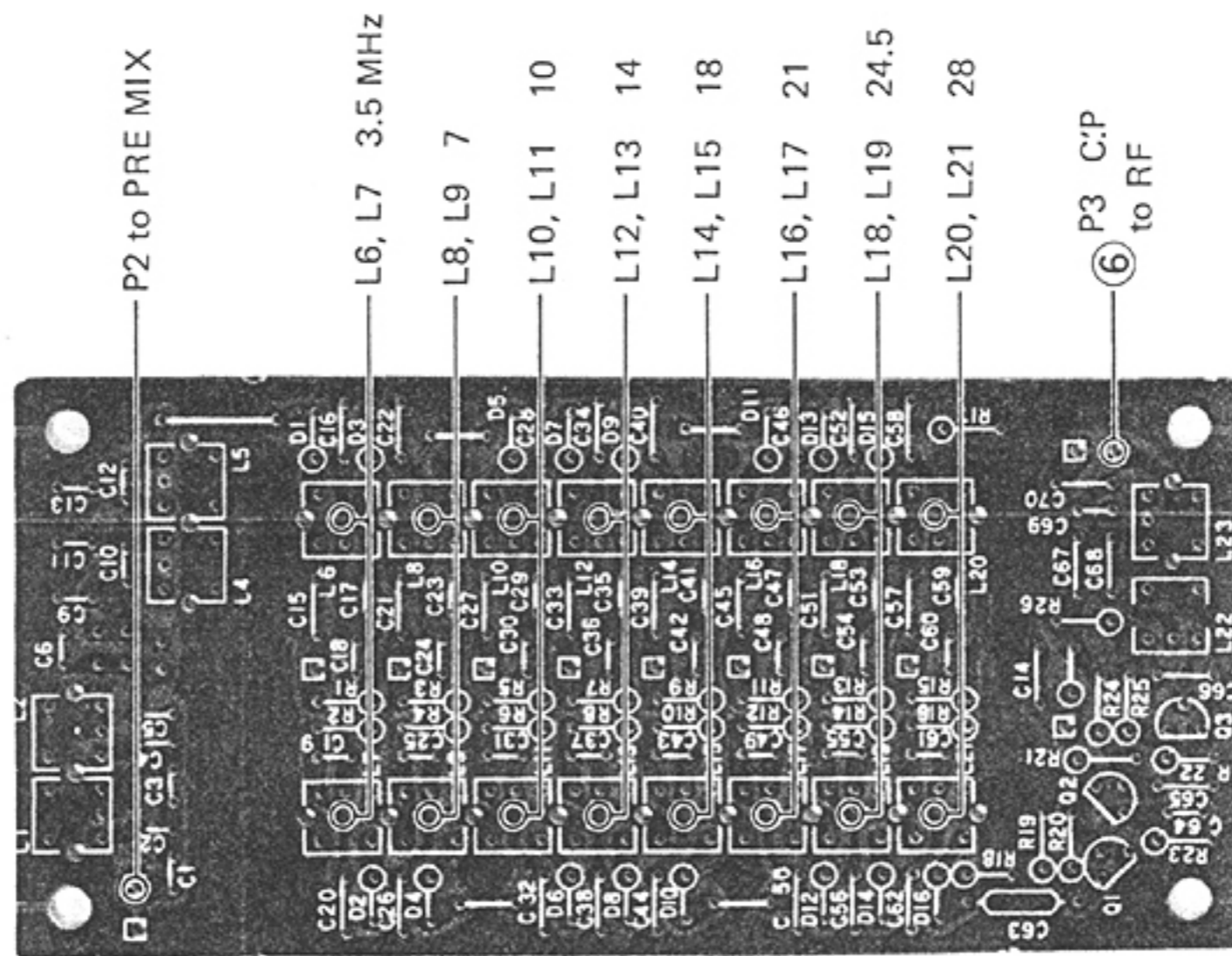

8 - 3 RECEIVER ADJUSTMENT

Adjustment item	Adjusting procedures	Measuring location			Adjusting location		Instrument reading	Number of adjusting location
		Measuring instruments	UNIT	Terminal	UNIT	Parts		
AGC GAIN adjustment	<p>Adjusting conditions:</p> <ul style="list-style-type: none"> o MODE: USB o Displayed frequency: 14.098.5 MHz. o RF GAIN: MAX o IF SHIFT: CENTER o RIT : OFF o AGC: FAST o PRE AMP: OFF <p>1) Connect the AC millivoltmeter to external SP terminal in parallel with 8-ohms speaker.</p> <p>2) Connect SSG to the ANT connector. Rotating the tuning control with the frequency set to 14.100.0 MHz, receive with the maximum reading of the millivoltmeter.</p> <p>3) With input from SSG set to +14 dBμ (loaded), adjust L1 of DET PCB for minimum reading.</p> <p>4) Adjust AF GAIN so that reading of the millivoltmeter becomes 1 V.</p> <p>5) With SSG output turned OFF, adjust L6 of MAIN UNIT so that reading of the millivoltmeter is lowered 30 dB than the reading obtained in above 4). At the time, adjust L6 in the direction where core goes down.</p>	AC millivoltmeter 8-ohms speaker SSG	Rear panel Rear panel	EXT. SP ANT	UNIT DET MAIN	L1 L6	Minimum	201 202

Adjustment item	Adjusting procedures	Measuring location				Adjusting location		Instrument reading	Number of adjusting location
		Measuring instruments	UNIT	Terminal	UNIT	Parts			
S meter SET	<ol style="list-style-type: none"> 1) With input from SSG set to +14 dBμ (terminating value), adjust R42 of MAIN UNIT for S2 on the S-meter. 2) With input from SSG set to +84 dBμ adjust at R41 of MAIN UNIT for full scale on the S-meter. 3) Repeat above 1) and 2) several times. 	SSG (+14 dB μ) (+84 dB μ)			MAIN MAIN	R42 R41	S = 2 S = FULL	203 204	
Receiving sensitivity measurement	<p>Confirm that: With the PREAMP switch turned OFF, the receiving sensitivity is -10 dBμ/SN ratio 10 dB or more.</p> <p>With the PREAMP switch turned ON, the receiving sensitivity is -16 dBμ/SN ratio 10 dB or more in all bands.</p>								
N.B. Check	Confirm that N.B. has effect by applying NOISE signal from ANT connector in all bands.								

8 - 4 TRANSMITTER ADJUSTMENT

Adjustment item	Adjusting procedures	Measuring location			Adjusting location		Instrument reading	Number of adjusting location
		Measuring instruments	UNIT	Terminal	UNIT	Parts		
SWR meter adjustment	<ol style="list-style-type: none"> 1) Set the mode switch to CW, band switch to 14 MHz and meter to RF. 2) Connect 50-ohms dummy Load or RF wattmeter to the ANT connector. 3) Rotate R82 of MAIN UNIT and RF POWER Control fully clockwise. 4) Set S1 of MAIN UNIT to SWR. 5) Adjust C31 of FILTER PCB so that the meter deflection becomes minimum in transmit mode. 	50-ohms dummy Load or RF wattmeter	Rear panel	ANT (R82) (S1)			Minimum meter deflection.	301
ALC adjustment	<ol style="list-style-type: none"> 1) Set the mode switch to CW and band switch to 14 MHz. 2) Set S1 of MAIN UNIT to RF POWER side. Rotate RF POWER control on the front panel fully clockwise. 3) Connect 50-ohms wattmeter to the ANT connector. 4) Set meter switch on the front panel to ALC side. 5) Ground the KEY terminal on the rear panel. 	RF wattmeter	Rear panel.	(S1) ANT				

Adjustment item	Adjusting procedures	Measuring location				Adjusting location		Instrument reading	Number of adjusting location
		Measuring instruments	UNIT	Terminal	UNIT	Parts			
ALC adjustment (continued)	<p>6) Adjust R150 of the MAIN unit so that reading of RF wattmeter becomes 100W.</p> <p>7) Set the RF POWER control on the front panel to minimum.</p> <p>8) Adjust R149 of MAIN UNIT for 10W</p> <p>9) Adjust R91 of the MAIN unit so that the meter deflection becomes at the right end on the ALC scale.</p> <p>10) Repeat adjustment of above 6) and 8) several times.</p>				MAIN	R150	100W	302	
					MAIN	R149	10W	303	
					MAIN	R91		304	
AM 40W adjustment	<p>1) Set the mode switch to AM. Rotate RF POWER control on the front panel fully clockwise.</p> <p>2) Adjust R151 of MAIN UNIT so that the RF wattmeter's reading becomes 40W.</p>				MAIN	R151	40W	305	
Confirming of current on each band	<p>1) Removing upper solder on R48 of RF UNIT.</p> <p>2) Confirm CW and AM power in each band. CW: 90 ~ 120W, AM: 35 ~ 50W</p> <p>* For 28 MHz band, see the next page.</p>		(R48)	⑭			Confirming RF power. CW: 90 ~ 120W AM: 35 ~ 50W		

Adjustment item	Adjusting procedures	Measuring location			Adjusting location		Instrument reading	Number of adjusting location
		Measuring instruments	UNIT	Terminal	UNIT	Parts		
Confirming of current on each band (continued)	3) Make sure that total current at 100W CW does not exceed 19A. 4) Return solder to the initial place.						Confirming of current. CW: 19A in any band.	
50W adjustment	1) Set S3 of MAIN UNIT to 50W side, and adjust R168 of the MAIN UNIT for 60W. Confirm that the output power on other bands is within 40 to 70W range. 2) Then, return S3 to 100W side.	RF wattmeter	Rear panel	ANT	MAIN	R168	60W 40 to 70W in the bands other than 28 MHz.	306
SSB carrier balancing adjustment	1) Set mode switch to SSB, SPEECH PROCESSOR switch (S2 of MAIN UNIT) to OFF and MIC GAIN control to minimum. 2) Connect a spectrum analyzer to the ANT connector and adjust R44 and R45 of DET PCB so that the carrier leak at LSB and USB becomes minimum.	Spectrum analyzer	Rear panel	(S2) ANT	DET	R44, R45	Confirm that carrier level is between 50 and 60 dB below carrier (CW 100W) in any band.	307

Adjustment item	Adjusting procedures	Measuring location				Adjusting location		Instrument reading	Number of adjusting location
		Measuring instruments	UNIT	Terminal	UNIT	Parts			
Speech processor adjustment	<ol style="list-style-type: none"> 1) Set mode switch to SSB or AM. 2) Connect an AF oscillator to MIC connector. Oscillator output: 1.5 kHz 100mV 3) Connect oscilloscope to R103 of MAIN UNIT. 4) Adjust R99 of MAIN UNIT so that clipping waveform on the oscilloscope becomes equal. 	AF oscillator	Front	MIC	MAIN	R99	Waveform clip should be symmetrical in upper and lower side.	308	
RF meter adjustment	<ol style="list-style-type: none"> 1) Set meter switch to RF side, S1 of the MAIN UNIT to POWER side, mode switch to CW, band to 14 MHz and RF power control to MAX. 2) Adjust R82 of MAIN unit so that RF meter becomes full scale. 3) With S1 of MAIN UNIT set to SWR side, confirm that the meter indicates 1.2 or less on the SWR scale (in any band). 	RF meter			MAIN	R82	Full scale 1.2 or less	309	
APC check	<ol style="list-style-type: none"> 1) Remove cable of ANT connector during transmission as above. 2) Confirm that total current at that time is less than 10A. 						Confirm that total current in any band is less than 10A.		

MAIN UNIT

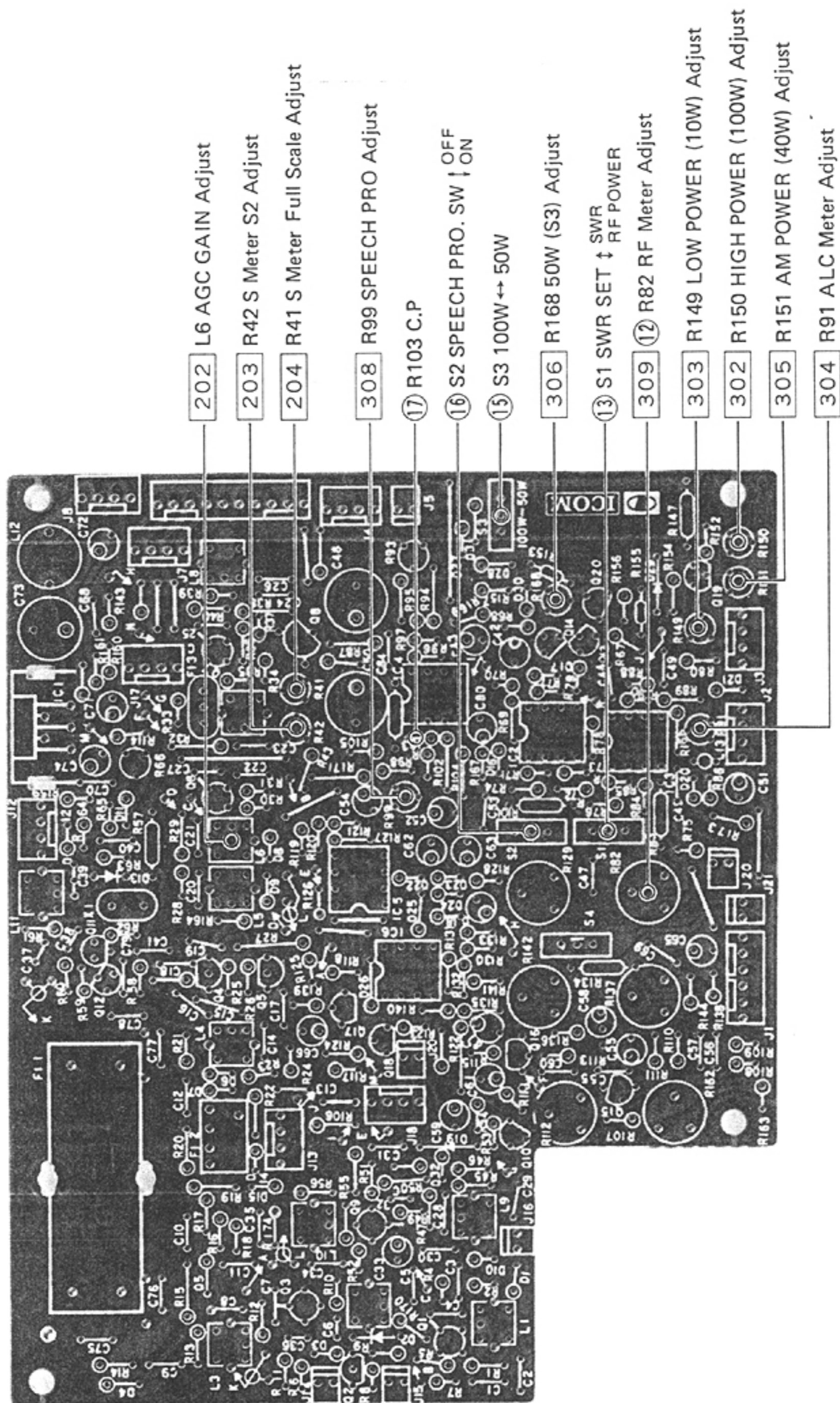

RF UNIT

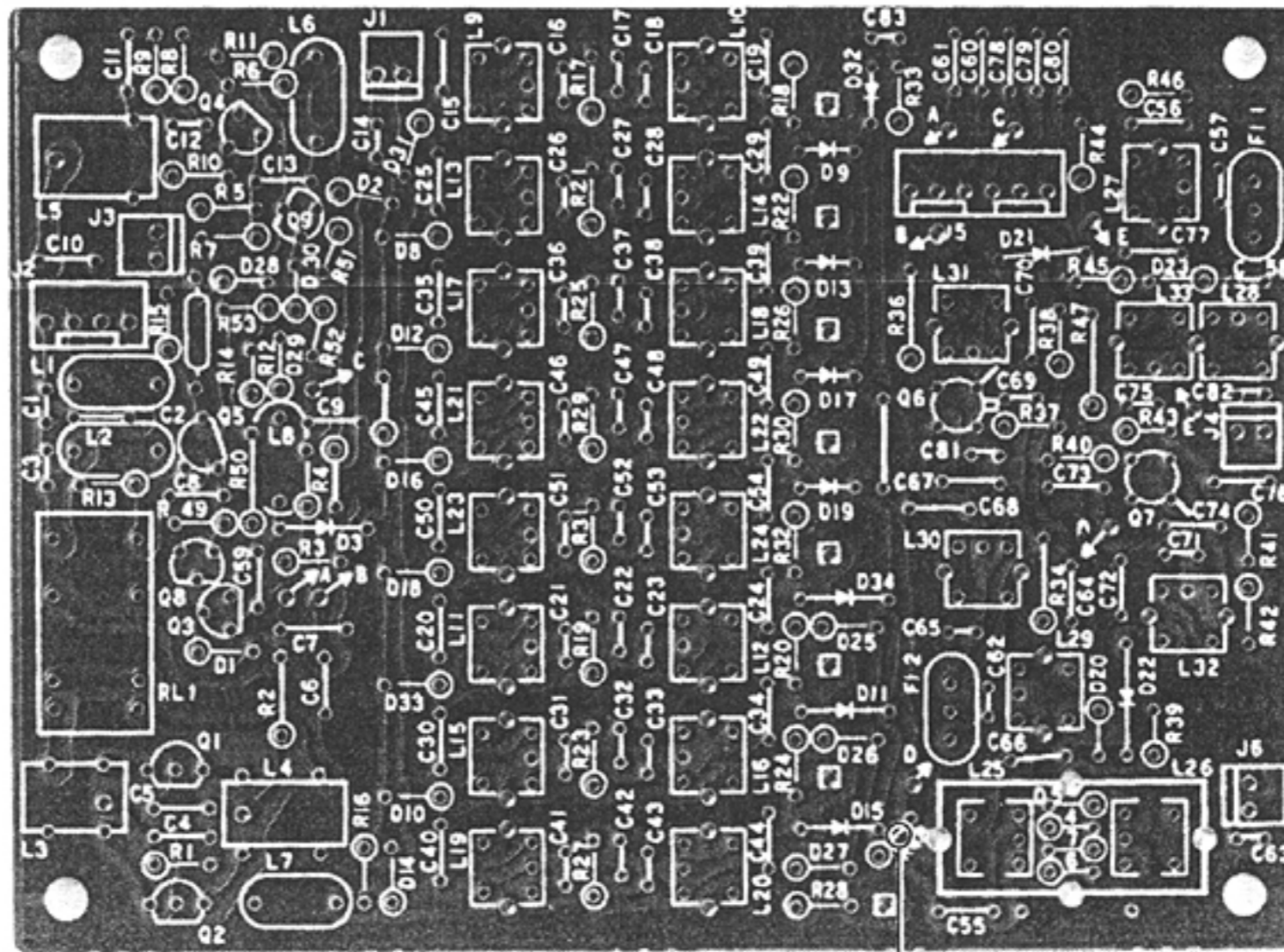

R48 (14)

DET UNIT

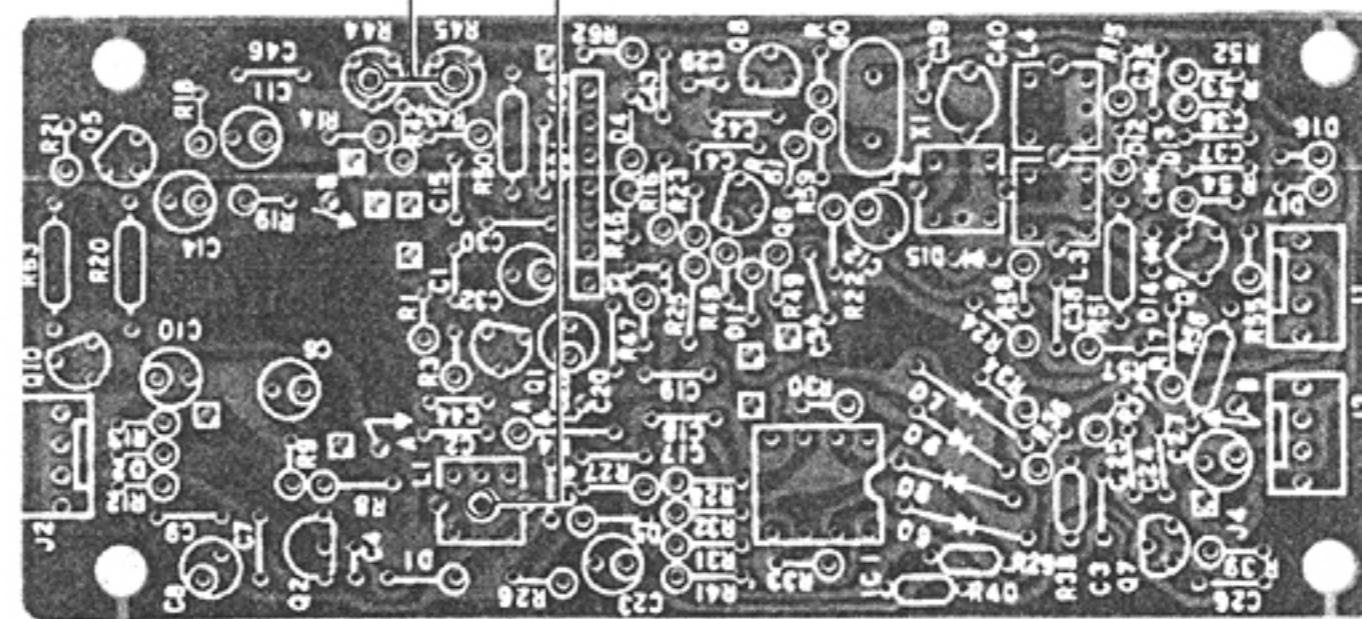

307 R44, R45
Carrier Null Adjust
(SSB)

201 L1 AGC GAIN } Adjust
S Meter

FILTER UNIT

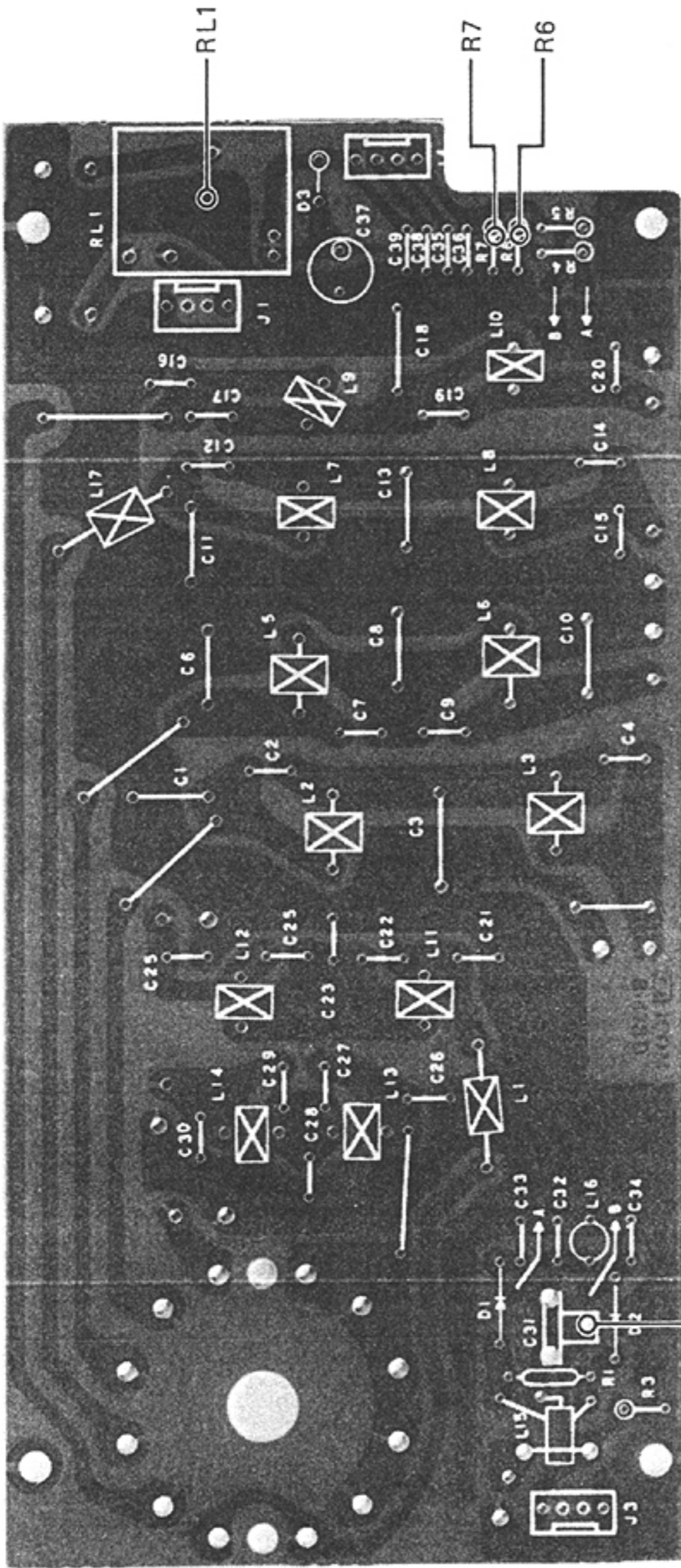

DISPLAY BOARD

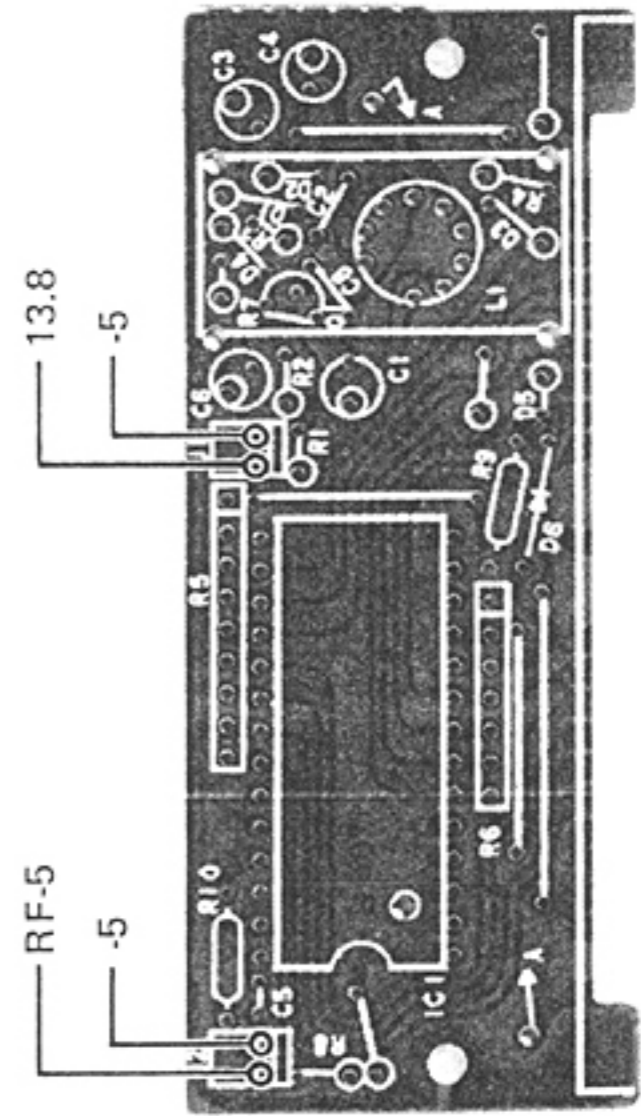

SENSOR BOARD

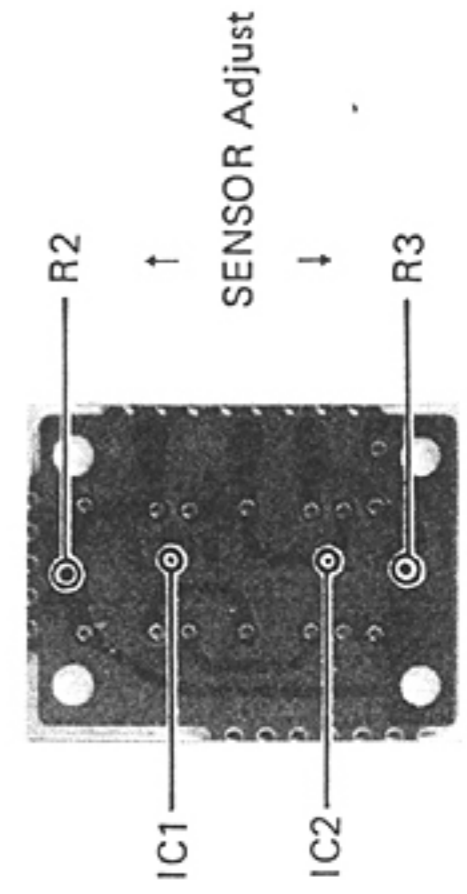

SECTION 9 VOLTAGE (CIRCUIT) DIAGRAM

MAIN UNIT CIRCUIT & VOLTAGE DIAGRAM

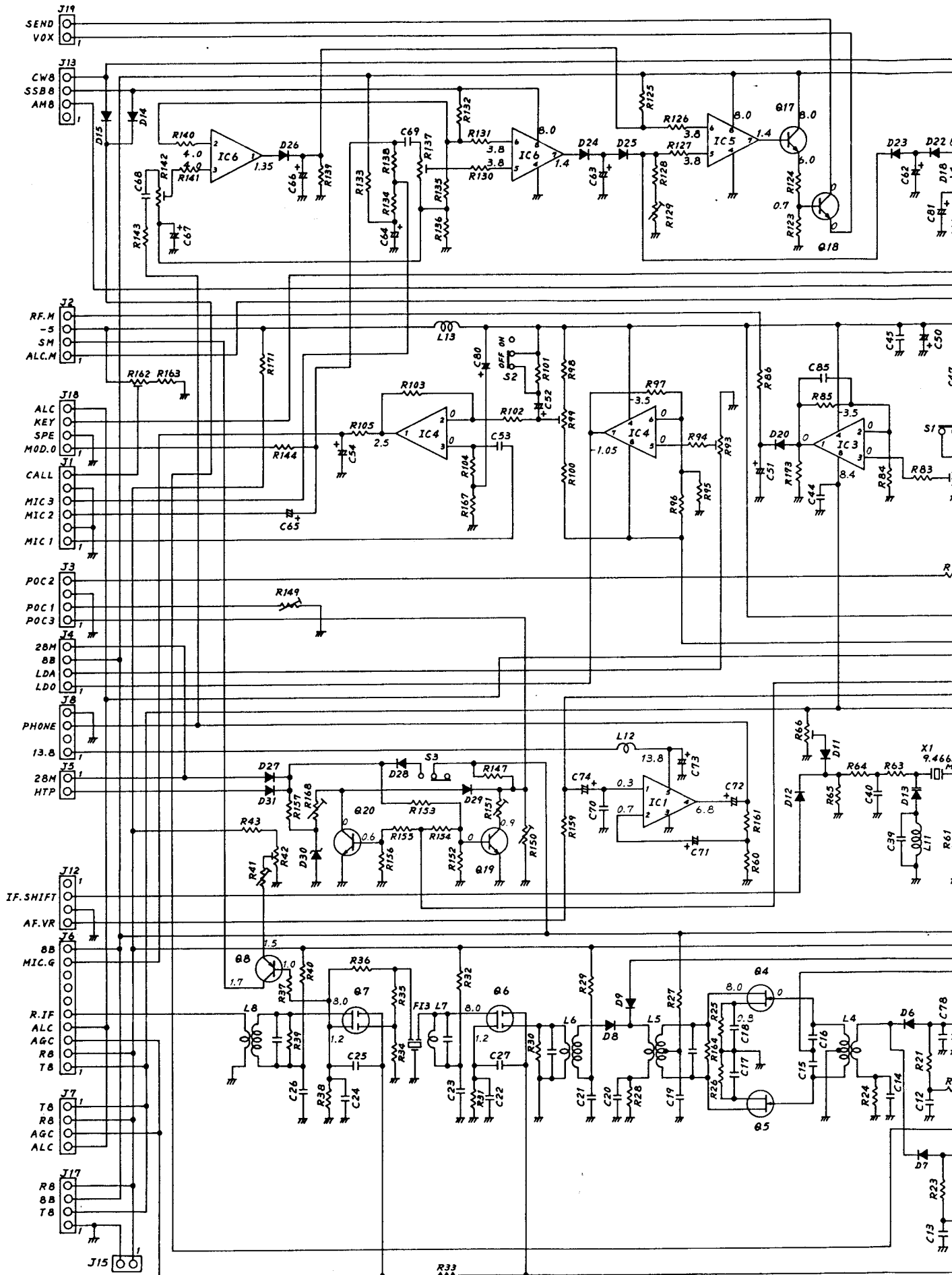

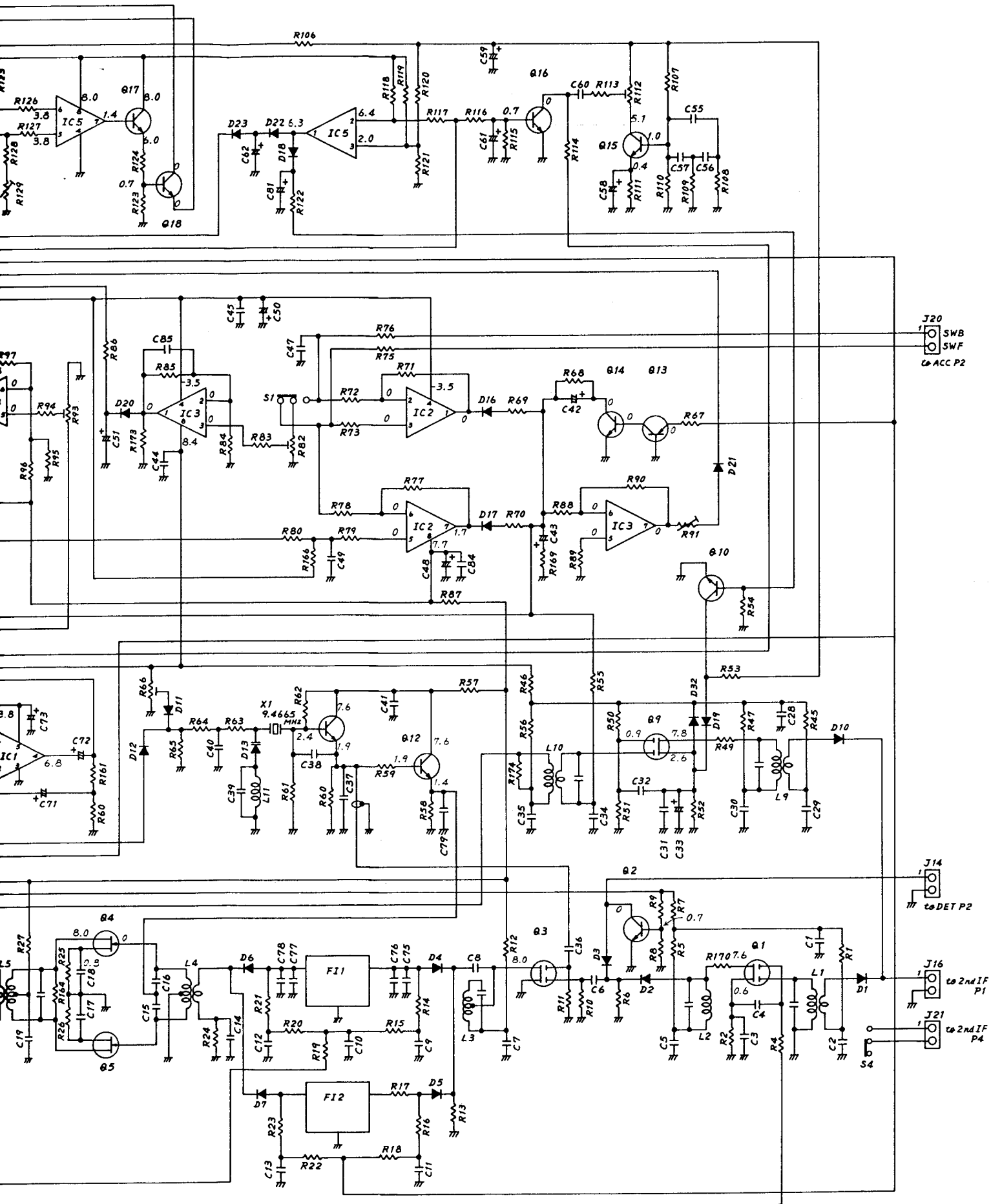

RF UNIT CIRCUIT & VOLTAGE DIAGRAM

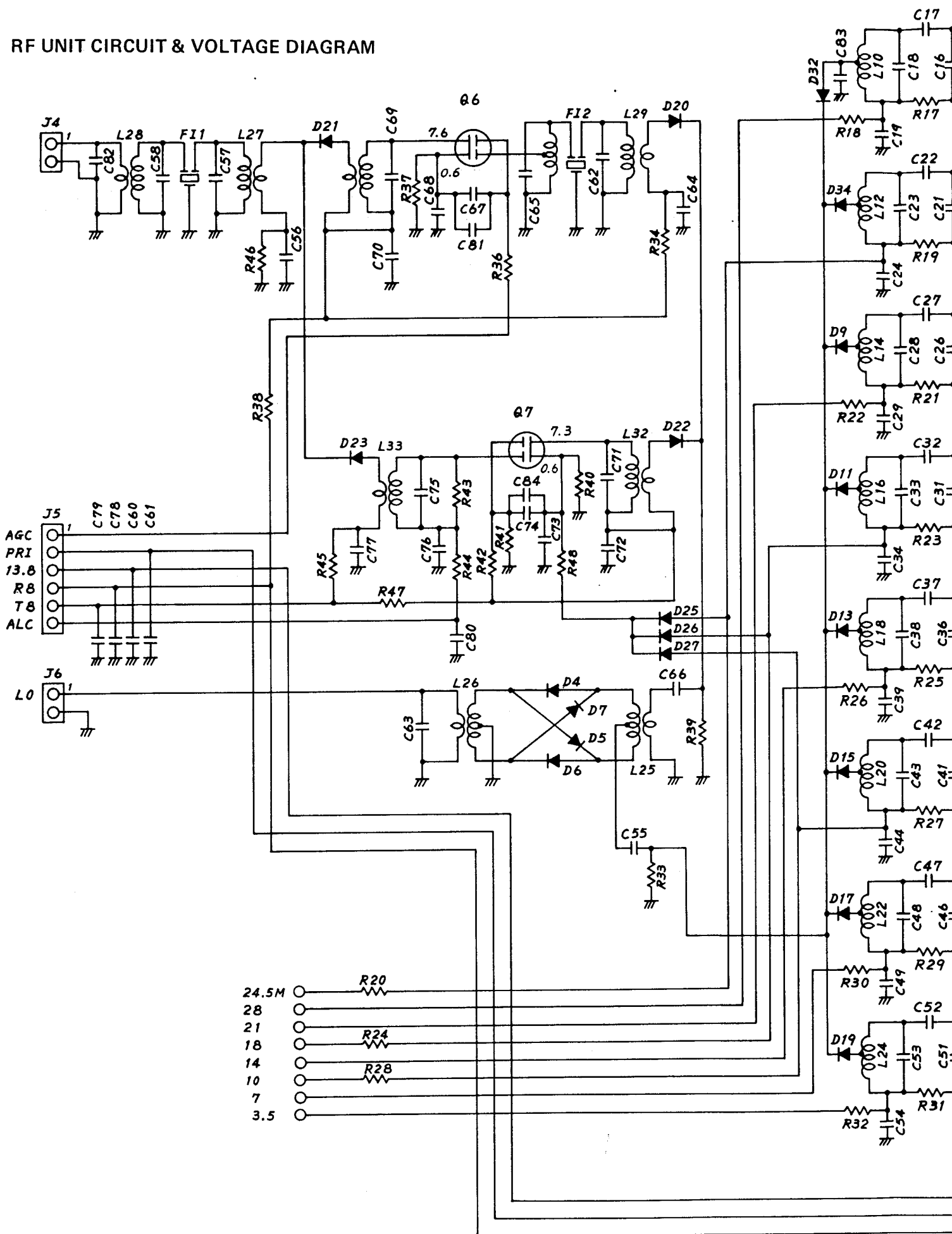

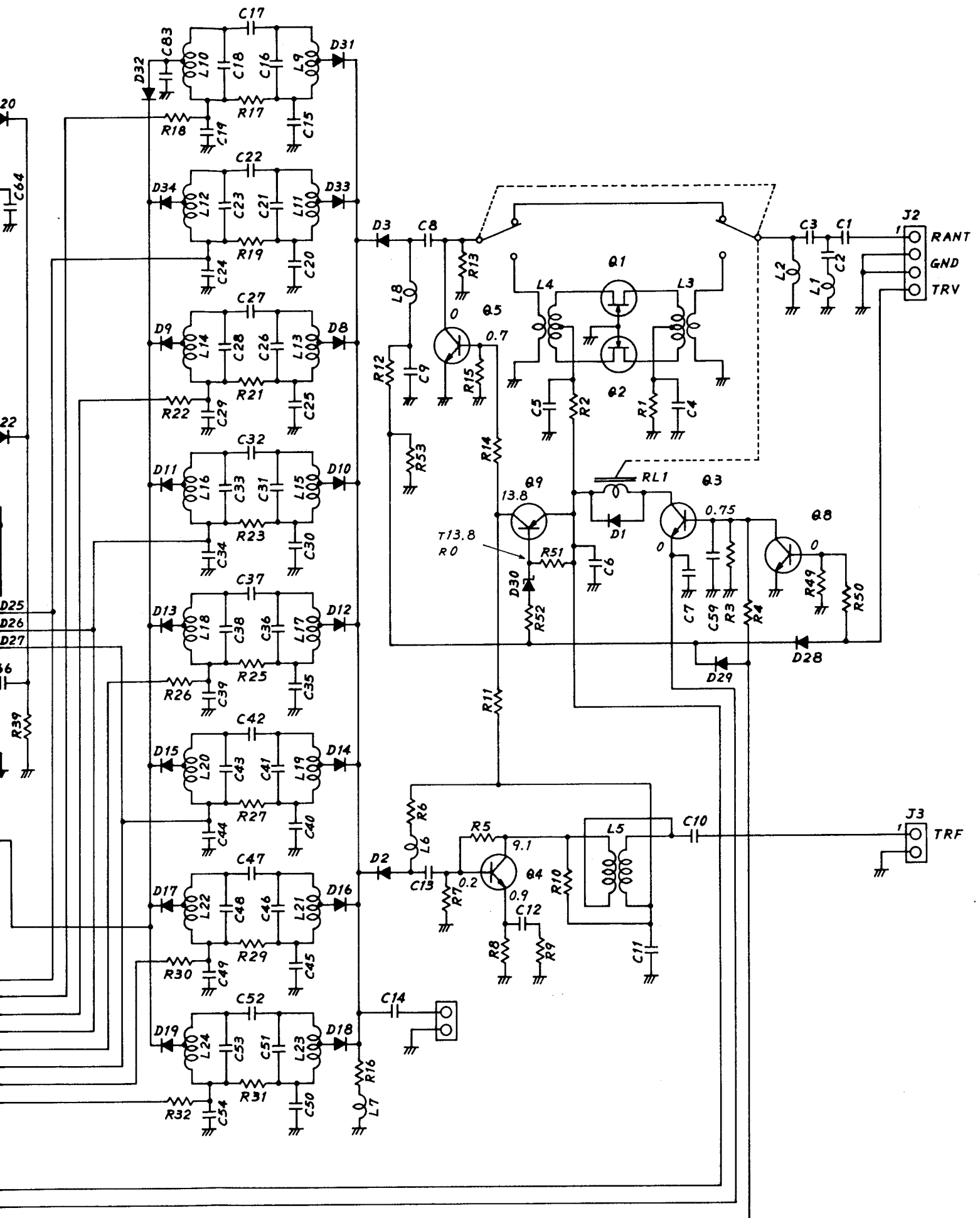

LOGIC UNIT CIRCUIT & VOLTAGE DIAGRAM

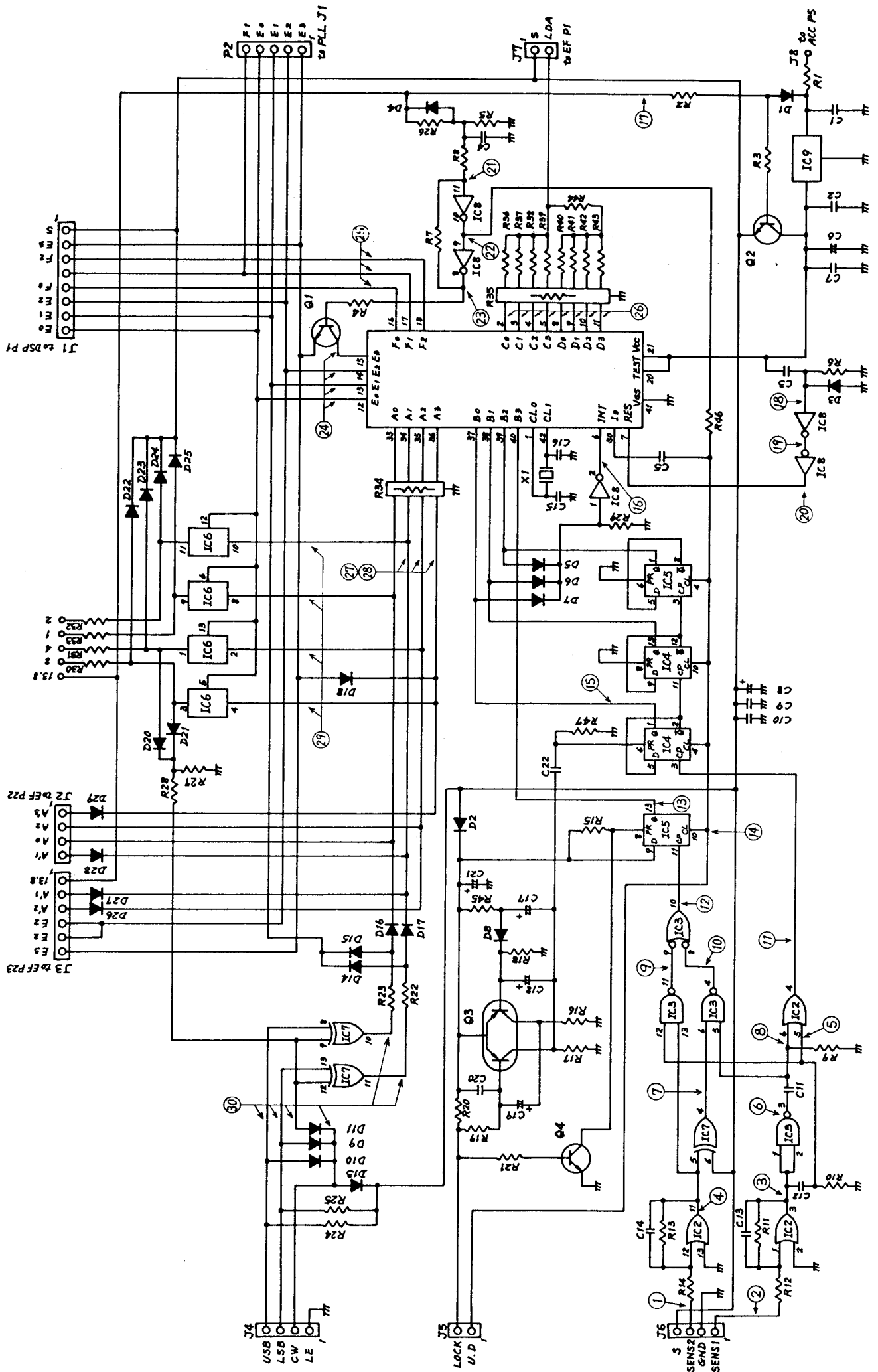

LOGIC UNIT VOLTAGE WAVEFORMS

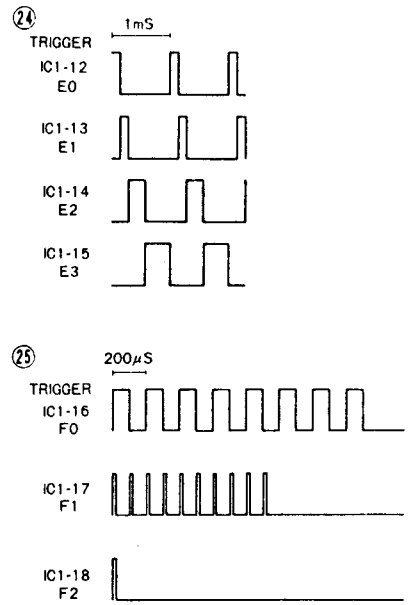
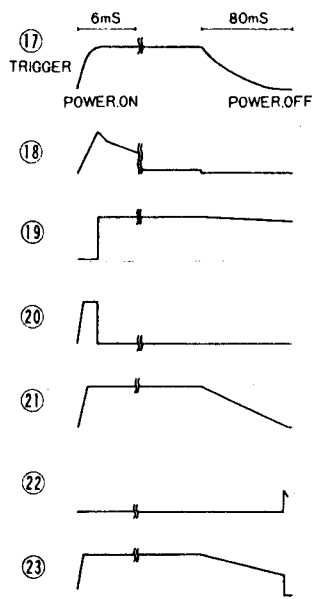
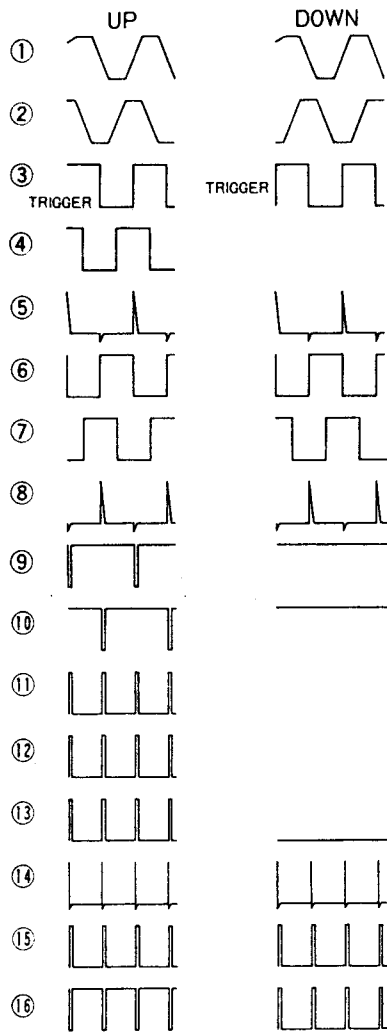

27 VFO MEMORY

IC1 PIN NO.	33 A0	34 A1	35 A2	36 A3
VFO A	L			
VFO B	H			
MEMORY OFF		L		
MEMORY ON		H		
NOR			L	
SPT			H	
WRITE OFF				L
WRITE ON				H

IC1-14/E2) TRIGGER

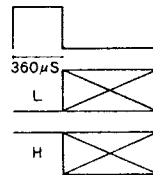

28 VFO PITCH

IC1 PIN NO.	33 A0	34 A1	35 A2	36 A3
VFO 10Hz	H	L	L	H
VFO 100Hz	L	H	H	H
VFO 1KHz	L	L	L	H
POWER OFF				L
POWER ON				H

IC1-15/E3) TRIGGER

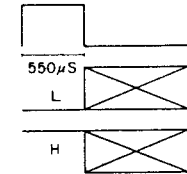

26 IC1 D/A DATA OUT

PIN NO. / FREQ.	2 C0	3 C1	4 C2	5 C3	8 D0	9 D1	10 D2	11 D3
0.00 KHz	L	L	L	L	L	L	L	L
0.01	L	L	L	L	H	L	L	L
0.02	L	L	L	L	L	H	L	L
0.03	L	L	L	L	L	H	L	L
0.04	L	L	L	L	L	L	H	L
0.05	L	L	L	L	H	L	H	L
0.06	L	L	L	L	L	H	H	L
0.07	L	L	L	L	H	H	H	L
0.08	L	L	L	L	L	L	L	H
0.09	L	L	L	L	H	L	L	H
0.10	H	L	L	L	L	L	L	L
0.11	H	L	L	L	H	L	L	L
0.12	H	L	L	L	L	H	L	L
0.13	H	L	L	L	H	H	L	L
0.95	H	L	L	H	L	L	H	L
0.96	H	L	L	H	H	H	H	L
0.97	H	L	L	H	L	H	H	L
0.98	H	L	L	H	H	L	L	H
0.99	H	L	L	H	L	L	L	H
1.00	L	L	L	L	L	L	L	L
0.0 KHz	L	L	L	L				
0.1	H	L	L	L				
0.2	L	H	L	L				
0.3	H	H	L	L				
0.4	L	L	H	L				
0.5	H	L	H	L				
0.6	L	H	H	L				
0.7	H	H	H	L				
0.8	L	L	L	H				
0.9	H	L	L	H				
1.0	L	L	L	L				

29 BAND SW

PIN NO. / BAND	IC6 8-9	IC6 10/11	IC6 1-2	IC6 3-4
3.5 MHz	L	H	L	L
7	H	H	L	L
10	L	L	H	L
14	H	L	H	L
18	L	H	H	L
21	H	H	H	L
24.5	L	L	L	H
28	H	L	L	H
28.5	L	H	L	H
29	H	L	H	H
29.5	L	L	H	H
NC	L	L	L	L

IC1-12/E0) TRIGGER

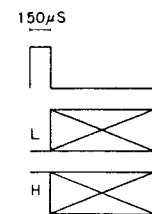

30 MODE SW

BAND	MODE	J4 2	J4 3	J4 4	J4 8	IC7 9	IC7 13	IC7 10	IC7 11
35~7 MHz	CW	L	L	L	L	L	L	L	L
	LSB	H	L	H	H	L	L	H	L
	USB	H	H	L	L	L	H	L	H
10~28 MHz	CW	L	L	L	L	L	L	L	L
	LSB	H	L	H	H	H	L	L	H
	USB	H	H	L	L	H	H	H	L

PLL UNIT CIRCUIT & VOLTAGE DIAGRAM

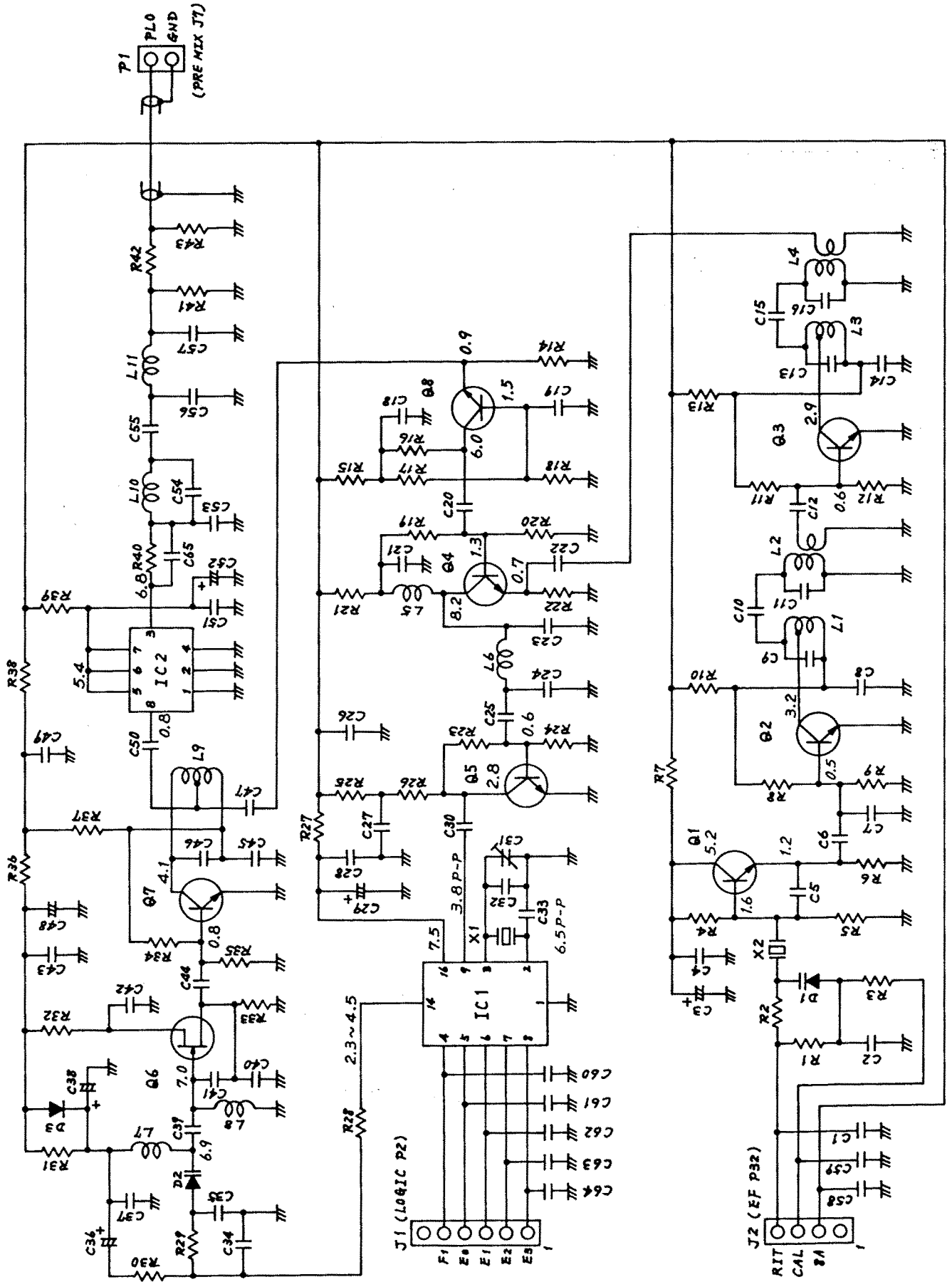

2ND IF UNIT CIRCUIT & VOLTAGE DIAGRAM

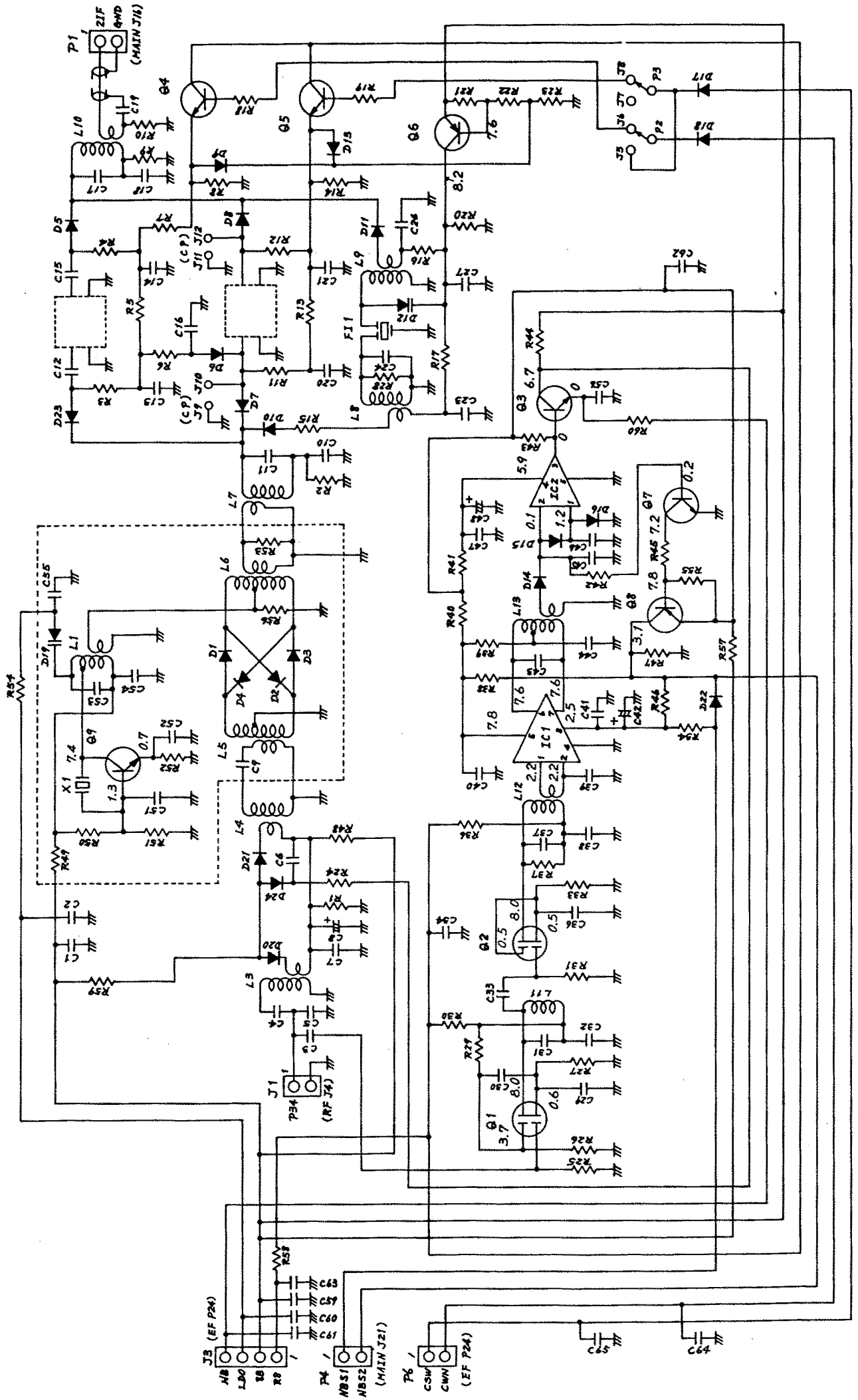

PRE. MIX UNIT CIRCUIT & VOLTAGE DIAGRAM

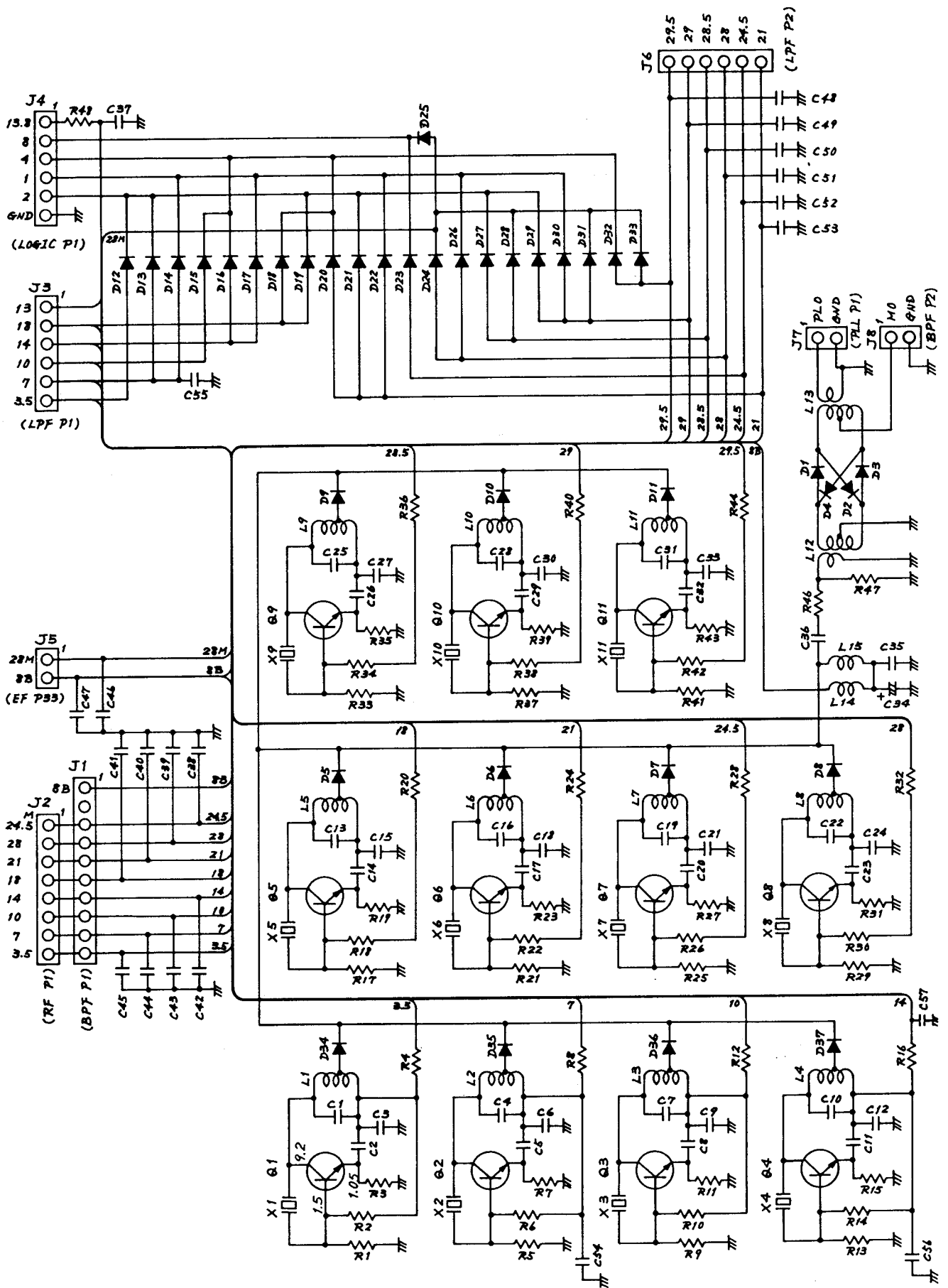

DET UNIT CIRCUIT & VOLTAGE DIAGRAM

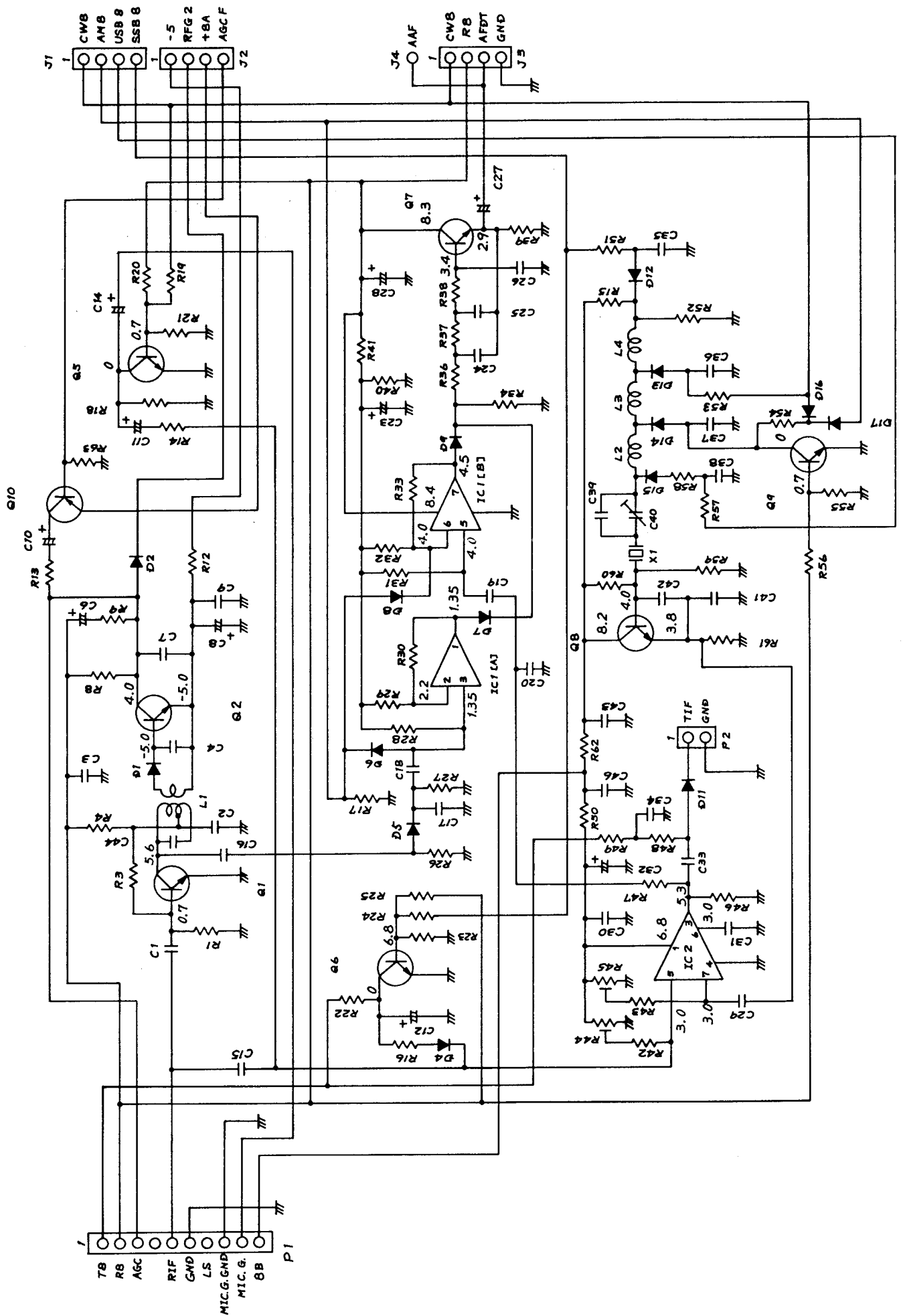

BAND PASS FILTER UNIT CIRCUIT & VOLTAGE DIAGRAM

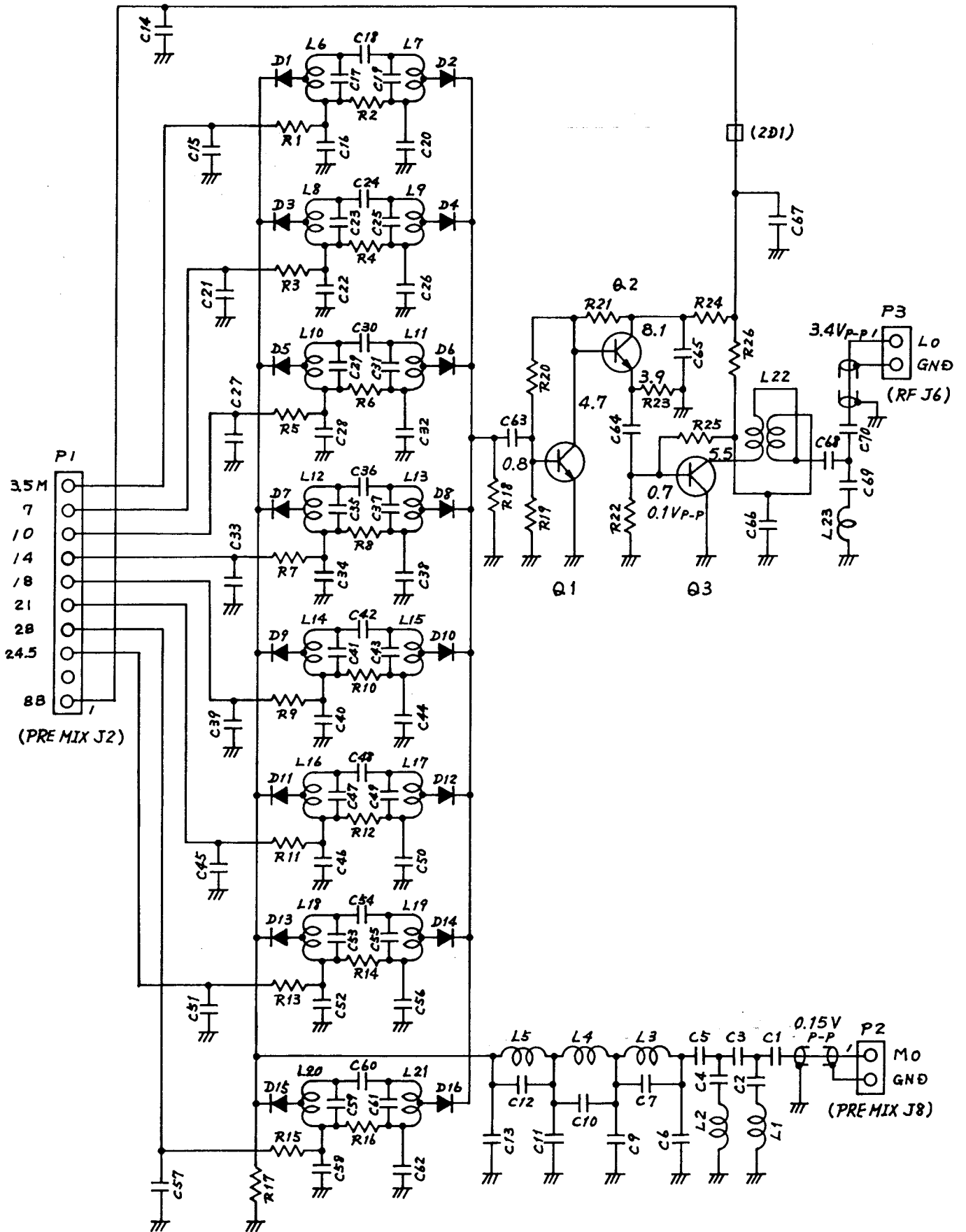

FILTER UNIT CIRCUIT DIAGRAM

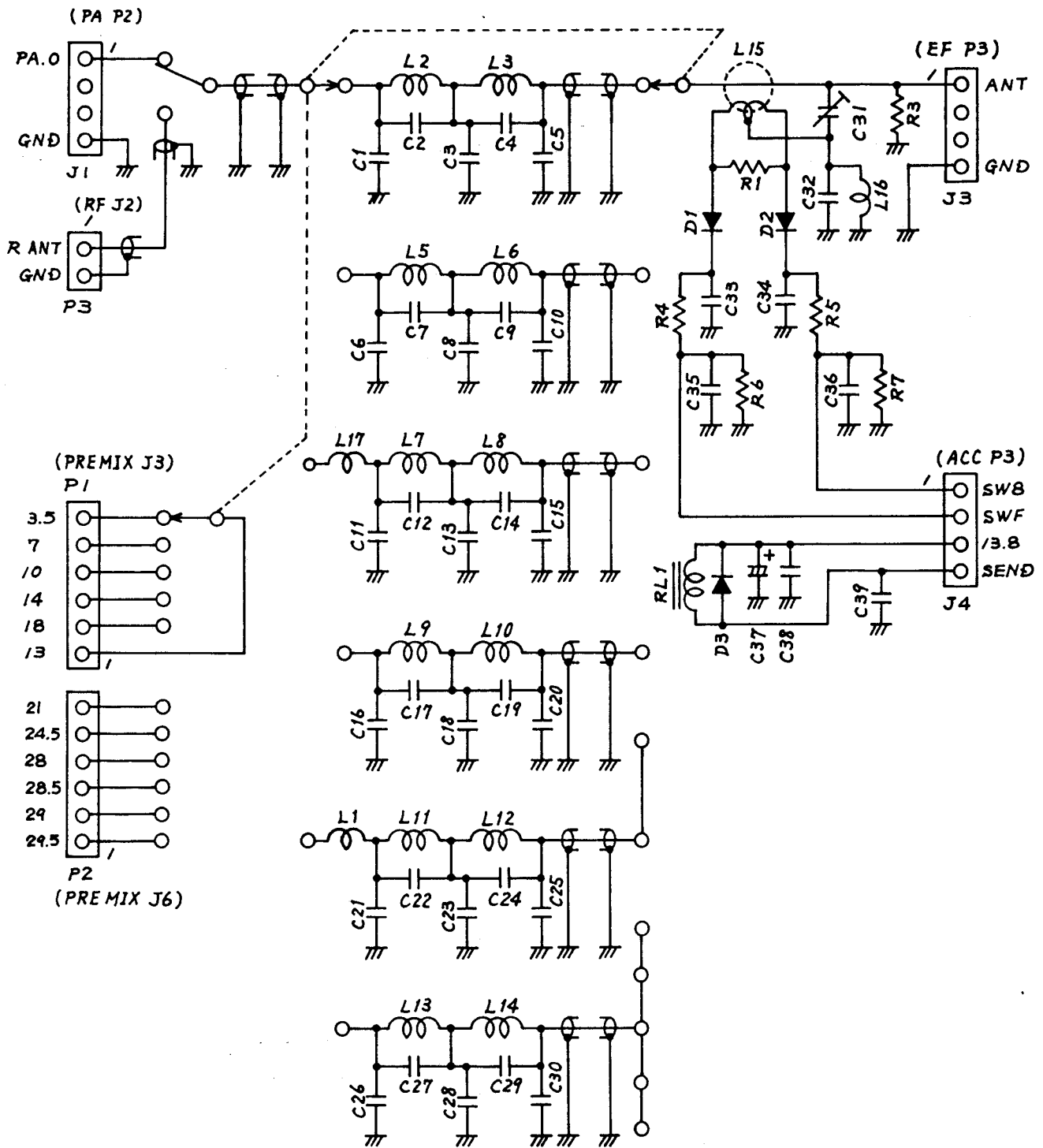

DISPLAY UNIT CIRCUIT DIAGRAM

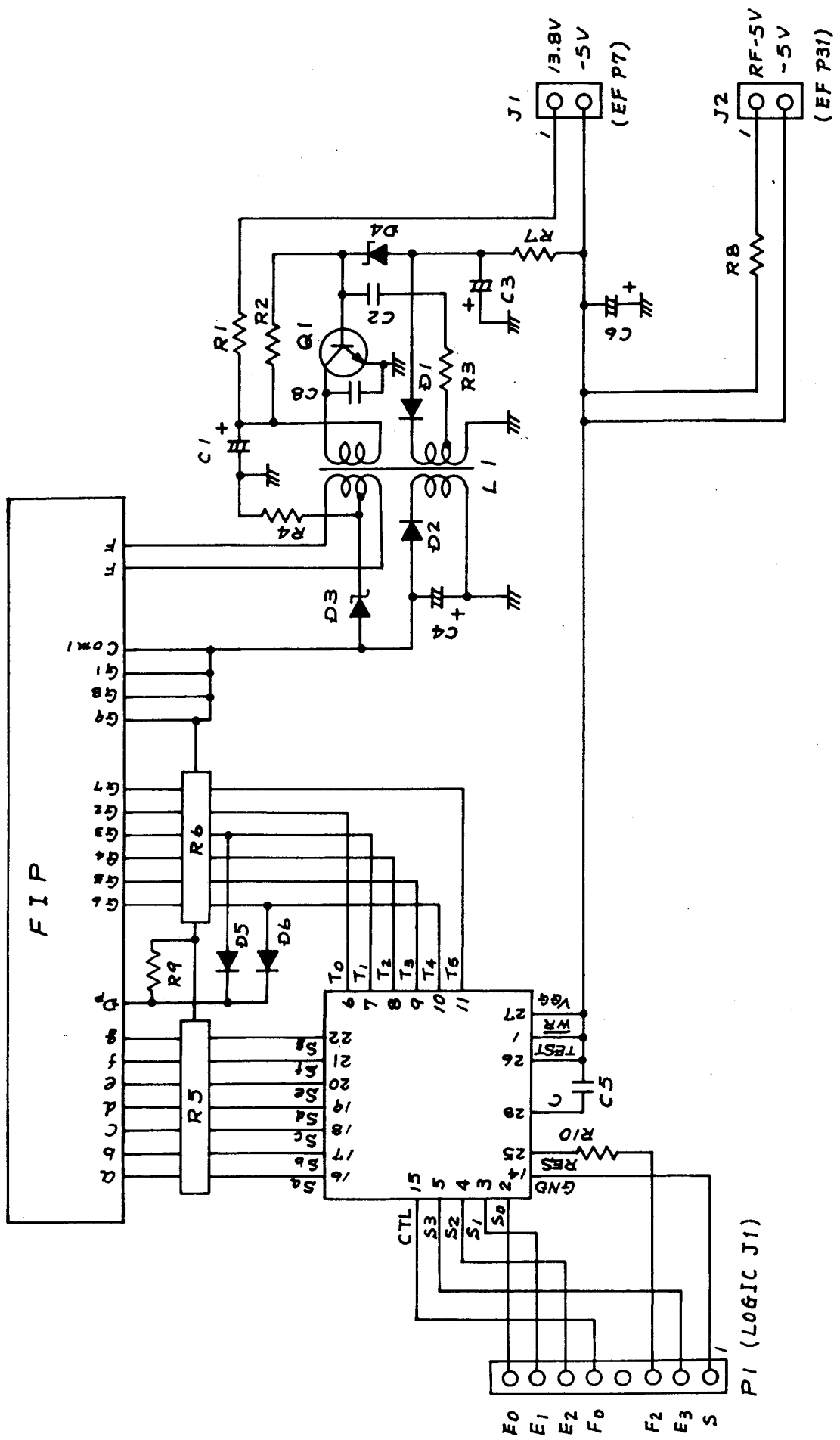

PA UNIT CIRCUIT & VOLTAGE DIAGRAM

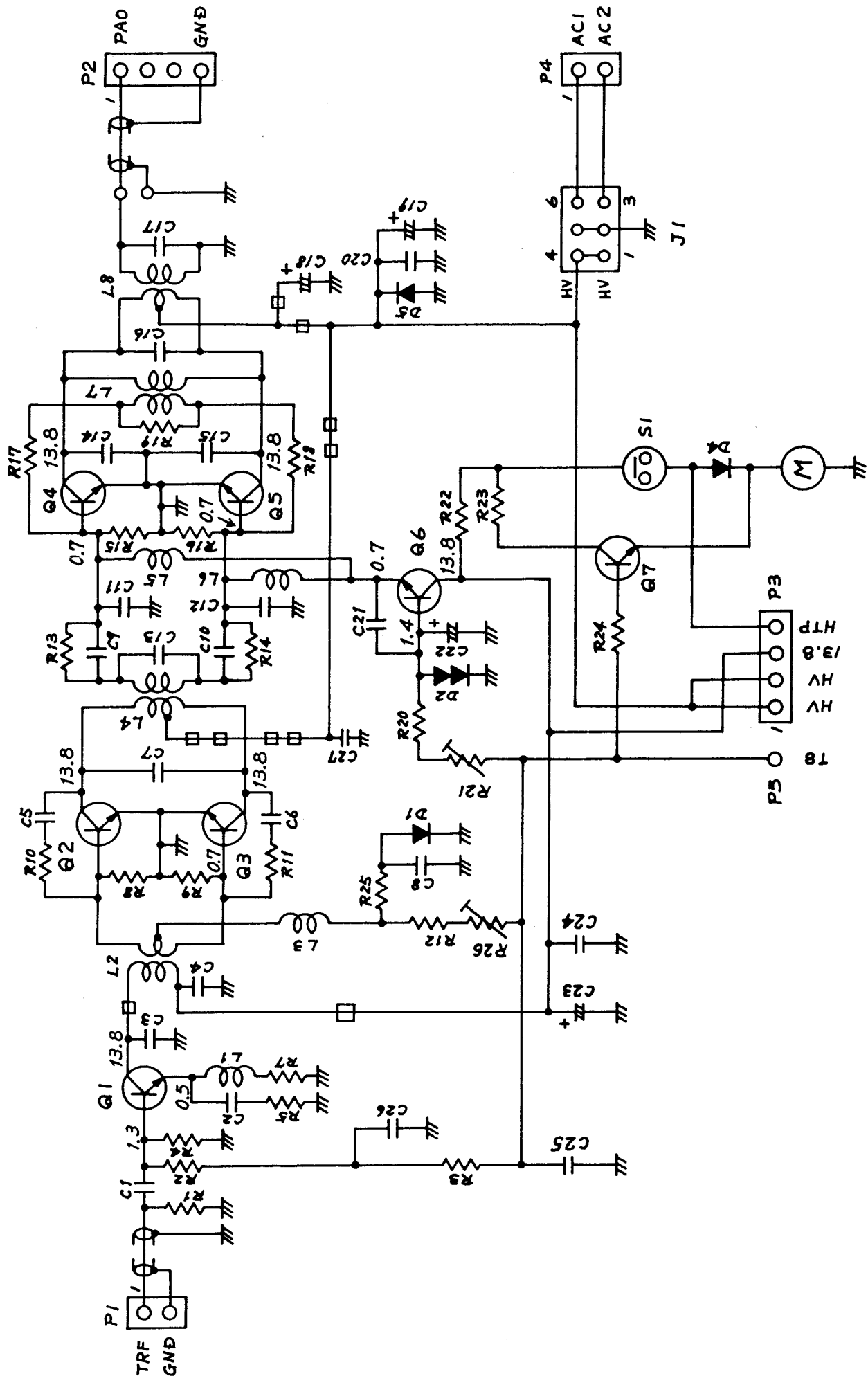

ACC UNIT CIRCUIT DIAGRAM

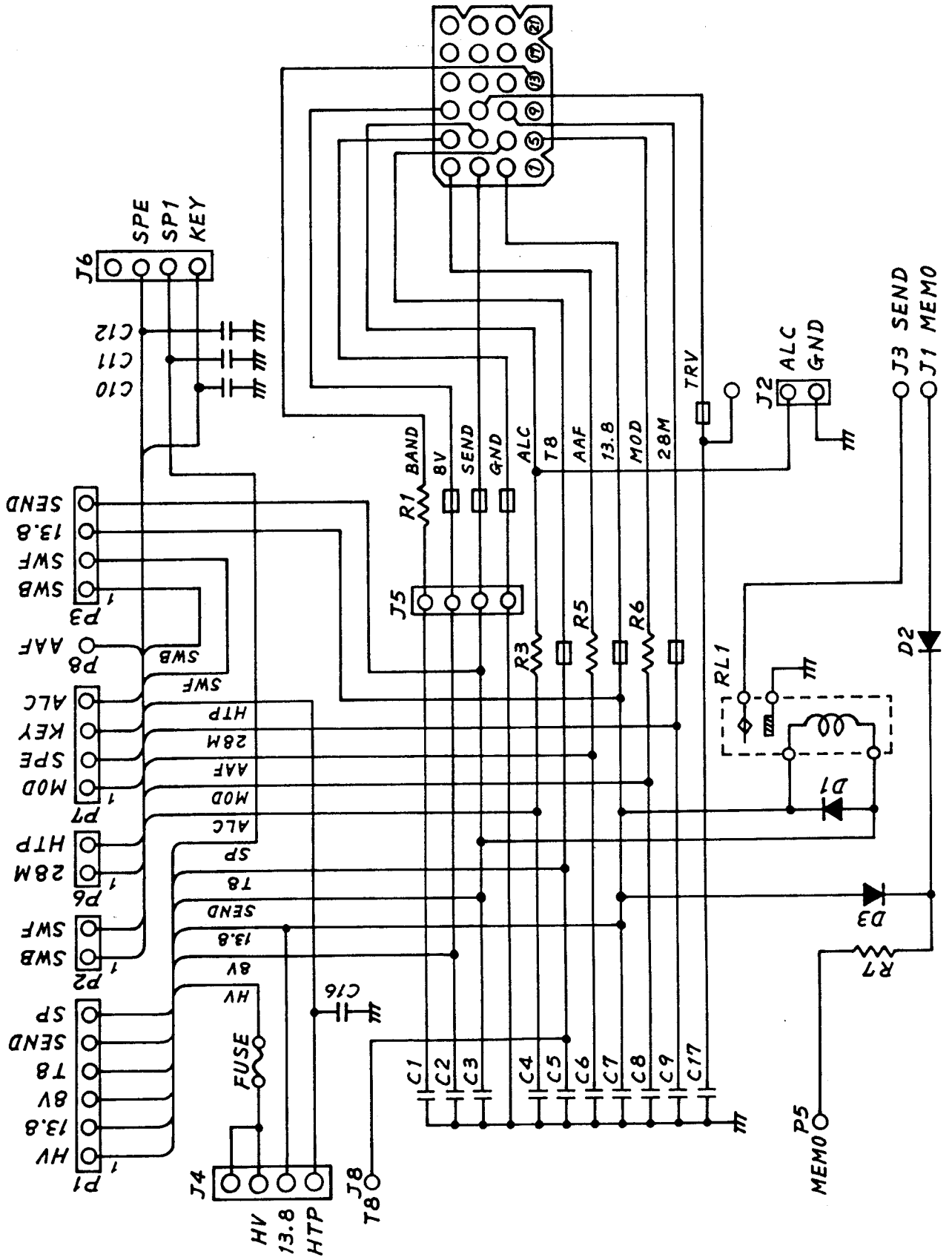

REG UNIT CIRCUIT DIAGRAM

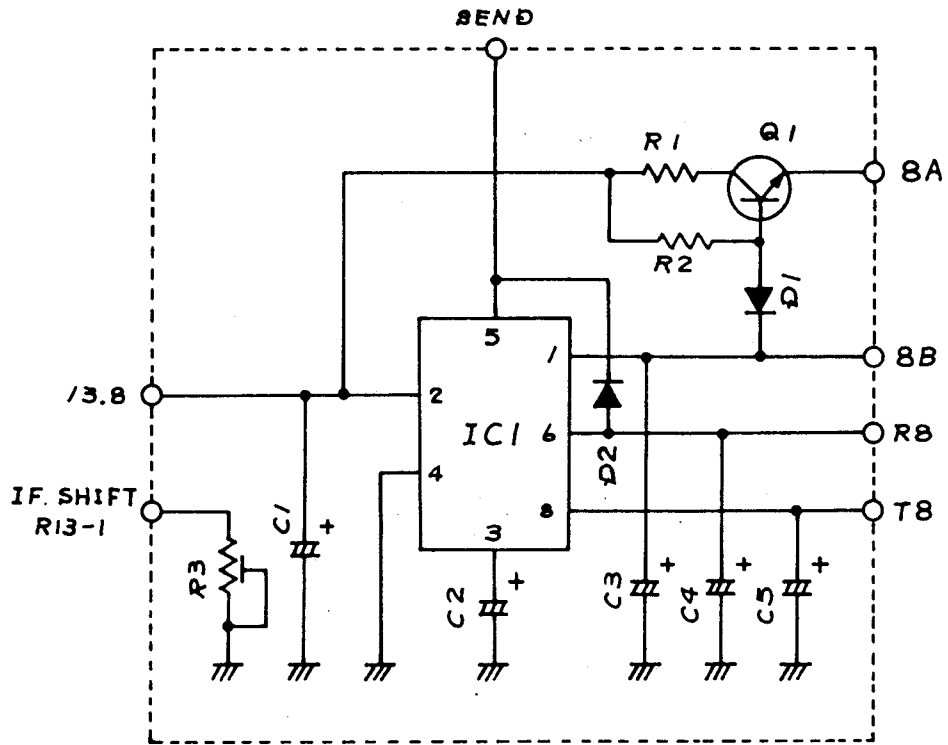

SENCOR UNIT CIRCUIT DIAGRAM

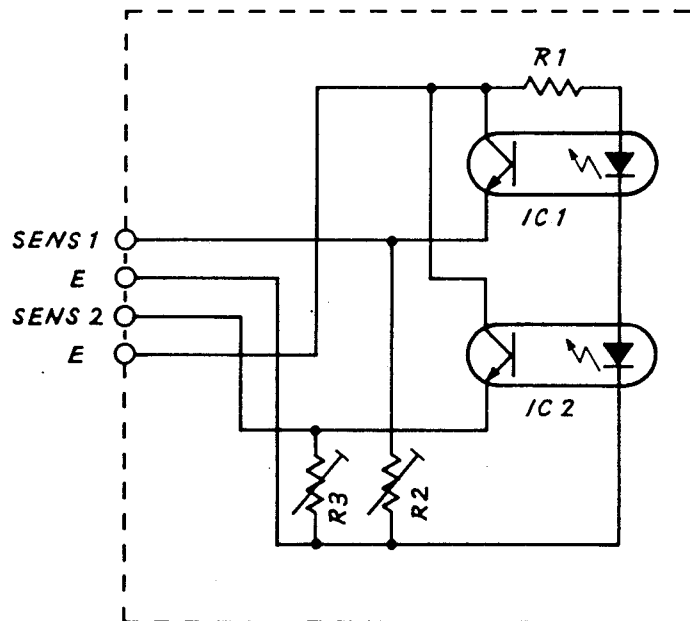

SECTION 10 PARTS LIST

[EF] UNIT				[EF] UNIT			
REF. NO.	DESCRIPTION	PART NO.		REF. NO.	DESCRIPTION	PART NO.	
Q1	Transistor	2SA1015		J1	Connector	LJ035-1-2 (PHONES)	
Q2	Transistor	2SK30-Y		J2	Connector	FM214-8SS (MIC)	
D1	Diode	1SS53		J4	Pin Jack	AT-700 (EXT ALC)	
D2	Diode	1SS53		J5	Pin Jack	AT-700 (M BACK UP)	
D3	Diode	1SS53		J6	Jack	LJ102 (KEY)	
D4	Diode	1SS53		J7	Jack	HSJ0779-01A (EXT SP)	
D5	Diode	1SS53		J9	Jack	FM-MD-RM1 (ANT)	
D6	Diode	1SS53		J13	Universal	SQ-2054 (GROUND)	
D7	Diode	1SS53		B1	PC. Board	B-483B (RIT)	
D8	LED	GL-9PR2		B2	PC. Board	B-484A (SW1)	
D9	LED	GL-9PR2		B3	PC. Board	B-485C (SW2)	
R1	Resistor	1.2K	R25	B4	PC. Board	B-486A (MIC)	
R2	Trimmer	RGP053	10K	P1	Connector	5250-2A	
R3	Trimmer	RGP053	10K	P2	Connector	5250-2A	
R4	VR (RIT)	K121B	10K	P3	Connector	5250-2A	
R5	Resistor	100K	R25	P4	Connector	5250-4A	
R6	Resistor	220K	R25	P6	Connector	5250-2A	
R7	Resistor	6.8K	ELR25	P7	Connector	5250-2A	
R8	VR (AF/RF)	K16B1 10K A(IN) 10K A		P11	Connector	5250-2A	
R9	Resistor	470K	R25	P12	Connector	5250-4A	
R10	Resistor	10K	ELR25	P13	Connector	5250-4A	
R12	Resistor	10K	R25	P14	Connector	5250-4A	
R13	VR (PB SHIFT)	S2011A503 10K B		P15	Connector	5250-4A	
R14	VR(MIC/RF PWR)	K16B1 10K BX2		P16	Connector	5250-4A	
R15	Resistor	100	R25	P17	Connector	5250-4A	
R16	Resistor	100	R25	P18	Connector	5250-4A	
R17	Resistor	1.2K	R25	P20	Connector	5250-6A	
R18	Surge Absorber	DS-301		P21	Connector	5250-4A	
R19	Resistor	100K	ELR25	P22	Connector	5250-4A	
C1	Electroly	0.47	50V	RC2	Connector	5250-4A	
C2	Electroly	0.1	50V	RC2	Connector	5250-4A	
C3	Ceramic	0.0022	50V	P25	Connector	1545P-1	
C4	Ceramic	0.0022	50V	P27	Connector	SMR-06V-B	
C5	Ceramic	0.0022	50V	P28	Connector	5250-04A	
C6	Ceramic	0.0022	50V	P29	Connector	5250-04A	
C7	Ceramic	0.0022	50V	P30	Connector	5250-06A	
C8	Ceramic	0.0022	50V	P31	Connector	5250-02A	
C8	Ceramic	0.0047	50V	P32	Connector	5250-04A	
C9	Ceramic	0.0047	50V	P33	Connector	5250-02A	
C10	Ceramic	0.0047	50V	P34	Connector	5250-02A	
L1	Choke	101	L4	P35	Connector	5250-02A	
L2	Choke	101	L4	P36	Connector	5250-02A	
L3	Choke	101	L4	P37	Connector	SMF-01T-1.3	
L4	Choke	101	L4	P38	Connector	5250-04A	
PL1	Lamp	BQ044-32582A		P39	Connector	5250-04A	
S1	Push Switch	SPJ222N Type (B) (RIT)		P40	Connector	1625-03P-1	
S2	Push Switch	SPJ222C Type (G) (METER)		P41	Connector	1625-03R-1	
S3	Push Switch	SUT111 (M/VFO WRITE)		P42	Universal	LED Socket	
S4	Push Switch	SUT111 (MEMORY)		P43	Universal	LED Socket	
S5	Push Switch	SUT528 (SW2)		FH1	Fuse Holder	SN11-2	
S6	Push Switch	SUH61H (SW1)		F1	Fuse	5A	
S7	Rotary SW	SRN2045N (MODE)					
S8	Switch	TW0068 (POWER)					

[RF] UNIT

REF. NO.	DESCRIPTION	PART NO.
Q1	FET	2SK125
Q2	FET	2SK125
Q3	Transistor	2SC945P
Q4	Transistor	2SC2053
Q5	Transistor	2SC945P
Q6	FET	3SK81 (3SK51)
Q7	FET	3SK74M
Q8	Transistor	2SC945
Q9	Transistor	2SB562
D1	Diode	1SS53
D2	Diode	1SS53
D3	Diode	1SS53
D4	Diode	1SS97
D5	Diode	1SS97
D6	Diode	1SS97
D7	Diode	1SS97
D8	Diode	1SS53
D9	Diode	1SS53
D10	Diode	1SS53
D11	Diode	1SS53
D12	Diode	1SS53
D13	Diode	1SS53
D14	Diode	1SS53
D15	Diode	1SS53
D16	Diode	1SS53
D17	Diode	1SS53
D18	Diode	1SS53
D19	Diode	1SS53
D20	Diode	1SS53
D21	Diode	1SS53
D22	Diode	1SS53
D23	Diode	1SS53
D25	Diode	1SS53
D26	Diode	1SS53
D27	Diode	1SS53
D28	Diode	1SS53
D29	Diode	1SS53
D30	Zener	XZ082
D31	Diode	1SS53
D32	Diode	1SS53
D33	Diode	1SS53
D34	Diode	1SS53
FI1	Crystal Filter	39M15A (39.7315MHz)
FI2	Crystal Filter	39M15A (39.7315MHz)
R1	Resistor	22 ELR25
R2	Resistor	22 ELR25
R3	Resistor	10K ELR25
R4	Resistor	22K ELR25
R5	Resistor	4.7K R25
R6	Resistor	100 ELR25
R7	Resistor	680 ELR25
R8	Resistor	4.7 R25
R9	Resistor	1 ELR25
R10	Resistor	220 R25
R11	Resistor	56 ELR25
R12	Resistor	100 ELR25
R13	Resistor	10K ELR25
R14	Resistor	4.7K R25
R15	Resistor	2.2K ELR25
R16	Resistor	100 ELR25
R17	Resistor	220 ELR25

[RF] UNIT

REF. NO.	DESCRIPTION	PART NO.
R18	Resistor	47 ELR25
R19	Resistor	220 ELR25
R20	Resistor	47 ELR25
R21	Resistor	220 ELR25
R22	Resistor	47 ELR25
R23	Resistor	220 ELR25
R24	Resistor	47 ELR25
R25	Resistor	220 ELR25
R26	Resistor	47 ELR25
R27	Resistor	220 ELR25
R28	Resistor	47 ELR25
R29	Resistor	220 ELR25
R30	Resistor	47 ELR25
R31	Resistor	220 ELR25
R32	Resistor	47 ELR25
R33	Resistor	390 ELR25
R34	Resistor	470 ELR25
R36	Resistor	1M ELR25
R37	Resistor	150 ELR25
R38	Resistor	100 ELR25
R39	Resistor	2.2K ELR25
R40	Resistor	150 ELR25
R41	Resistor	47K ELR25
R42	Resistor	47K ELR25
R43	Resistor	1K ELR25
R44	Resistor	470 ELR25
R45	Resistor	1K ELR25
R46	Resistor	2.2K ELR25
R47	Resistor	100 ELR25
R48	Resistor	680 R25
R49	Resistor	10K ELR25
R50	Resistor	22K ELR25
R51	Resistor	4.7K ELR25
R52	Resistor	1K ELR25
R53	Resistor	1K ELR25
C1	Barrier Lay	0.0012 50V
C2	Barrier Lay	0.0068 50V
C3	Barrier Lay	0.001 50V
C4	Barrier Lay	0.047 25V
C5	Barrier Lay	0.047 25V
C6	Barrier Lay	0.047 25V
C7	Barrier Lay	0.047 25V
C8	Ceramic	0.0047 50V
C9	Barrier Lay	0.047 25V
C10	Ceramic	0.0047 50V
C11	Barrier Lay	0.1 12V
C12	Barrier Lay	0.0015 50V
C13	Ceramic	0.0047 50V
C14	Ceramic	3P 50V
C15	Ceramic	0.0047 50V
C16	Ceramic	10P 50V
C17	Ceramic	1P 50V
C18	Ceramic	10P 50V
C19	Ceramic	0.0047 50V
C20	Ceramic	0.0047 50V
C21	Ceramic	15P 50V
C22	Ceramic	1.5P 50V
C23	Ceramic	15P 50V
C24	Ceramic	0.0047 50V
C25	Ceramic	0.0047 50V
C26	Ceramic	18P 50V
C27	Ceramic	2P 50V
C28	Ceramic	18P 50V

[RF] UNIT

REF. NO.	DESCRIPTION	PART NO.	
C29	Ceramic	0.0047	50V
C30	Ceramic	0.0047	50V
C31	Ceramic	8P	50V
C32	Ceramic	0.75P	50V
C33	Ceramic	8P	50V
C34	Ceramic	0.0047	50V
C35	Ceramic	0.0047	50V
C36	Ceramic	15P	50V
C37	Ceramic	1P	50V
C38	Ceramic	15P	50V
C39	Ceramic	0.0047	50V
C40	Ceramic	0.0047	50V
C41	Ceramic	24P	50V
C42	Ceramic	2P	50V
C43	Ceramic	24P	50V
C44	Ceramic	0.0047	50V
C45	Barrier Lay	0.047	25V
C46	Ceramic	47P	50V
C47	Ceramic	4P	50V
C48	Ceramic	47P	50V
C49	Barrier Lay	0.047	25V
C50	Barrier Lay	0.047	25V
C51	Ceramic	100P	50V
C52	Ceramic	22P	50V
C53	Ceramic	100P	50V
C54	Barrier Lay	0.047	25V
C55	Ceramic	0.0047	50V
C56	Ceramic	0.0047	50V
C57	Ceramic	5P	50V
C58	Ceramic	5P	50V
C59	Ceramic	0.0047	50V
C60	Barrier Lay	0.047	25V
C61	Barrier Lay	0.047	25V
C62	Ceramic	5P	50V
C63	Ceramic	10P	50V
C64	Ceramic	0.0047	50V
C65	Ceramic	5P	50V
C66	Ceramic	0.0047	50V
C67	Barrier Lay	0.1	12V
C68	Ceramic	0.0047	50V
C69	Ceramic	27P	50V
C70	Ceramic	0.0047	50V
C71	Ceramic	24P	50V
C72	Ceramic	0.0047	50V
C73	Ceramic	0.0047	50V
C74	Ceramic	0.0047	50V
C75	Ceramic	22P	50V
C76	Ceramic	220P	50V
C77	Ceramic	0.0047	50V
C78	Barrier Lay	0.047	12V
C79	Barrier Lay	0.047	12V
C80	Ceramic	0.0022	50V
C81	Ceramic	0.001	
C82	Ceramic	10P	
C83	Ceramic	22P	
C84	Ceramic	0.001	
L1	Coil	EL0810SKI-2R2K	
L2	Coil	EL0810SKI-1R8K	
L3	Coil	LR-18	
L4	Coil	LR-121	
L5	Coil	LR20	
L6	Choke	EL0810SKI-101K	
L7	Choke	EL0810SKI-101K	

[RF] UNIT

REF. NO.	DESCRIPTION	PART NO.
L8	Choke	EL0810SKI-101K
L9	Coil	LS-197
L10	Coil	LS-197
L11	Coil	LS-197
L12	Coil	LS-197
L13	Coil	LS-197
L14	Coil	LS-197
L15	Coil	LS-196
L16	Coil	LS-196
L17	Coil	LS-196
L18	Coil	LS-196
L19	Coil	LS-195
L20	Coil	LS-195
L21	Coil	LS-195
L22	Coil	LS-195
L23	Coil	LS-194
L24	Coil	LS-194
L25	Coil	LR-116
L26	Coil	LR-116
L27	Coil	LS-207
L28	Coil	LS-207
L29	Coil	LS-207
L30	Coil	LS-215
L31	Coil	LS-114
L32	Coil	LS-114
L33	Coil	LS-114
RL1	Relay	BR221D012
J1	Connector	5045-2A
J2	Connector	5045-4A
J3	Connector	5045-2A
J4	Connector	5045-2A
J5	Connector	5045-6A
J6	Connector	5045-2A
P1	Connector	5250-8A
B1	P.C. Board	B-474D

[2nd]IF] UNIT

REF. NO.	DESCRIPTION	PART NO.
IC1	IC	TA7124P
IC2	IC	M51201L
Q1	FET	3SK74M
Q2	FET	3SK74M
Q3	Transistor	2SC945P
Q4	Transistor	2SC945P
Q5	Transistor	2SC945P
Q6	Transistor	2SA1015
Q7	Transistor	2SC945P
Q8	Transistor	2SA1015
Q9	Transistor	2SC945P
D1	Diode	1SS99
D2	Diode	1SS99
D3	Diode	1SS99
D4	Diode	1SS99
D5	Diode	1SS53
D6	Diode	1SS53
D7	Diode	1SS53
D8	Diode	1SS53
D9	Diode	1SS53
D10	Diode	1SS53
D11	Diode	1SS53
D12	Varactor Diode	SVC303Y
D13	Diode	1SS53
D14	Diode	1N60
D15	Diode	1SS53
D16	Varistor	MV11
D17	Diode	1SS53
D18	Diode	1SS53
D19	Varactor Diode	1T25
D20	Diode	1S953
D21	Diode	1S953
D22	Diode	1SS53
D23	Diode	1SS53
D24	Diode	1S953
X1	Crystal	CR4 (30.72MHz)
F11	Crystal Filter	9M10A (9.0115MHz)
R1	Resistor	2.2K ELR25
R2	Resistor	1K ELR25
R3	Resistor	2.2K ELR25
R4	Resistor	2.2K ELR10
R5	Resistor	100 R25
R6	Resistor	10K ELR25
R7	Resistor	100 R25
R8	Resistor	10K ELR25
R9	Resistor	1K ELR25
R10	Resistor	1K ELR25
R11	Resistor	2.2K ELR25
R12	Resistor	2.2K ELR25
R13	Resistor	100 ELR25
R14	Resistor	1K ELR25
R15	Resistor	390 ELR25
R16	Resistor	2.2K ELR25
R17	Resistor	1.8K ELR25
R18	Resistor	10K ELR25
R19	Resistor	10K ELR25
R20	Resistor	10K ELR25
R21	Resistor	4.7K ELR25
R22	Resistor	22K ELR25

[2nd IF] UNIT

REF. NO.	DESCRIPTION	PART NO.
R23	Resistor	10K ELR25
R24	Resistor	100 ELR25
R25	Resistor	100K ELR25
R26	Resistor	100K ELR25
R27	Resistor	470 ELR25
R28	Resistor	15K ELR25
R29	Resistor	100K ELR25
R30	Resistor	100 R25
R31	Resistor	22K ELR25
R33	Resistor	470 ELR25
R34	Resistor	10K R25
R36	Resistor	100 R25
R37	Resistor	2.7K ELR25
R38	Resistor	15K R25
R39	Resistor	100 ELR25
R40	Resistor	22 ELR25
R41	Resistor	470 ELR25
R42	Resistor	100K ELR25
R43	Resistor	4.7K ELR25
R44	Resistor	1K ELR25
R45	Resistor	47K ELR25
R46	Resistor	100K ELR25
R47	Resistor	10K ELR25
R48	Resistor	4.7K R25
R49	Resistor	470 ELR25
R50	Resistor	22K ELR25
R51	Resistor	4.7K ELR25
R52	Resistor	270 ELR25
R53	Resistor	10K ELR25
R54	Resistor	10K ELR25
R55	Resistor	10K ELR25
R56	Resistor	10K R25
R57	Resistor	22 ELR25
R58	Resistor	22 ELR25
R59	Resistor	2.2K R25
R60	Resistor	100 ELR25
C1	Ceramic	0.0047 50V
C2	Ceramic	0.0047 50V
C3	Cylinder	100P 50V
C4	Ceramic	27P 50V
C5	Ceramic	68P 50V
C6	Mylar	0.01 50V
C7	Ceramic	0.0047 50V
C8	Electroly.	10 16V
C9	Ceramic	20P 50V
C10	Ceramic	0.0047 50V
C11	Ceramic	120P 50V
C12	Ceramic	0.001 50V
C13	Ceramic	0.0047 50V
C14	Ceramic	0.0047 50V
C15	Ceramic	0.001 50V
C16	Ceramic	0.0047 50V
C17	Ceramic	120P 50V
C18	Ceramic	0.0047 50V
C19	Ceramic	0.0047 50V
C20	Ceramic	0.0047 50V
C21	Ceramic	0.0047 50V
C22		
C23	Ceramic	0.0047 50V
C24	Ceramic	33P 50V
C25		
C26	Ceramic	0.0047 50V
C27	Ceramic	0.0047 50V

[2nd IF] UNIT

REF. NO.	DESCRIPTION	PART NO.	
C29	Ceramic	0.0047	50V
C30	Ceramic	0.001	50V
C31	Ceramic	12P	50V
C32	Ceramic	0.0047	50V
C33	Cylinder	10P	50V
C34	Ceramic	0.0047	50V
C36	Ceramic	0.0047	50V
C37	Ceramic	30P	50V
C38	Ceramic	0.0047	50V
C39	Ceramic	0.0047	50V
C40	Ceramic	0.0047	50V
C41	Ceramic	0.0047	50V
C42	Electroly.	0.47	50V
C43	Ceramic	15P	50V
C44	Ceramic	0.0047	50V
C45	Ceramic	100P	50V
C46	Ceramic	0.0047	50V
C47	Ceramic	0.0047	50V
C48	Electroly.	10	16V
C51	Ceramic	15P	50V
C52	Ceramic	0.0047	50V
C53	Ceramic	27P	50V
C54	Ceramic	0.0047	50V
C55	Ceramic	0.0047	50V
C56	Barrier Lay	0.1	12V
C59	Ceramic	0.0047	50V
C60	Ceramic	0.0047	50V
C61	Ceramic	0.0047	50V
C62	Ceramic	0.0047	50V
C63	Ceramic	0.0047	50V
C64	Ceramic	0.0047	50V
C65	Ceramic	0.0047	50V
L1	Coil	LS-198	
L3	Coil	LS-199	
L4	Coil	LS-199	
L5	Coil	LS-116	
L6	Coil	LS-116	
L7	Coil	LS-187	
L8	Coil	LS-188	
L9	Coil	LS-188	
L10	Coil	LS-187	
L11	Coil	LS-198	
L12	Coil	LS-189	
L13	Coil	LS-200	
J1	Connector	5045-2A	
J2			
J3	Connector	5045-4A	
J4	Connector	5045-2A	
J5	Connector	RT-01T-1.3B	
J6	Connector	RT-01T-1.3B	
J7	Connector	RT-01T-1.3B	
J8	Connector	RT-01T-1.3B	
J9	Connector	RT-01T-1.3B	
J10	Connector	RT-01T-1.3B	
J11	Connector	RT-01T-1.3B	
J12	Connector	RT-01T-1.3B	
P1	Connector	5250-2A	
P2	Connector	SMF-01T-1.3	
P3	Connector	SMF-01T-1.3	
P4	Connector	5250-02A	

[2nd IF] UNIT

REF. NO.	DESCRIPTION	PART NO.
B1	P.C. Board	B-475C
B2	P.C. Board	B-493A

[MAIN] UNIT

REF. NO.	DESCRIPTION	PART NO.	
IC1	IC	μPC2002V	
IC2	IC	NJM4558D	
IC3	IC	NJM4558D	
IC4	IC	NJM4558D	
IC5	IC	NJM4558D	
IC6	IC	NJM4558D	
Q1	FET	3SK74M	
Q2	Transistor	2SC945P	
Q3	FET	3SK74M	
Q4	FET	2SK19Y	
Q5	FET	2SK19Y	
Q6	FET	3SK74M	
Q7	FET	3SK74K	
Q8	Transistor	2SA1015	
Q9	FET	3SK74M	
Q10	Transistor	2SC945P or K	
Q11	Transistor	2SC945P	
Q12	Transistor	2SC945P	
Q13	Transistor	2SA1015	
Q14	Transistor	2SC945P	
Q15	Transistor	2SC945P	
Q16	Transistor	2SC945P	
Q17	Transistor	2SC1645	
Q18	Transistor	2SD468	
Q19	Transistor	2SC945P	
Q20	Transistor	2SC2458	
D1	Diode	1SS53	
D2	Diode	1SS53	
D3	Diode	1SS53	
D4	Diode	1SS53	
D5	Diode	1SS53	
D6	Diode	1SS53	
D7	Diode	1SS53	
D8	Diode	1SS53	
D9	Diode	1SS53	
D10	Diode	1SS53	
D11	Diode	1SS53	
D12	Diode	1SS53	
D13	Varactor Diode	1T25	
D14	Diode	1SS53	
D15	Diode	1SS53	
D16	Diode	1SS53	
D17	Diode	1SS53	
D18	Diode	1SS53	
D19	Diode	1SS53	
D20	Diode	1SS53	
D21	Diode	1SS53	
D22	Diode	1SS53	
D23	Diode	1SS53	
D24	Diode	1SS53	
D25	Diode	1SS53	
D26	Diode	1SS53	
D27	Diode	1SS53	
D28	Diode	1SS53	
D29	Diode	1SS53	
D30	Zener	XZ062	
D31	Diode	1SS53	
D32	Diode	1SS53	
R1	Resistor	3.3K	ELR25
R2	Resistor	680	ELR25
R4	Resistor	1M	ELR25

[MAIN] UNIT

REF. NO.	DESCRIPTION	PART NO.	
R5	Resistor	100	ELR25
R6	Resistor	4.7K	ELR25
R7	Resistor	100	ELR25
R8	Resistor	2.2K	ELR25
R9	Resistor	10K	ELR25
R10	Resistor	100K	ELR25
R11	Resistor	10K	ELR25
R12	Resistor	100	ELR25
R13	Resistor	4.7K	ELR25
R14	Resistor	3.3K	ELR25
R15	Resistor	220	ELR25
R16	Resistor	3.3K	ELR25
R17	Resistor	470	ELR25
R18	Resistor	220	ELR25
R19	Resistor	220	ELR25
R20	Resistor	220	ELR25
R21	Resistor	1.5K	ELR25
R22	Resistor	220	ELR25
R23	Resistor	3.3K	ELR25
R24	Resistor	2.2K	ELR25
R25	Resistor	470	ELR25
R26	Resistor	470	ELR25
R27	Resistor	100	ELR25
R28	Resistor	3.3K	ELR25
R29	Resistor	3.3K	ELR25
R30	Resistor	6.8K	ELR25
R31	Resistor	680	ELR25
R32	Resistor	100	ELR25
R33	Resistor	4.7K	ELR25
R34	Resistor	6.8K	ELR25
R35	Resistor	6.8K	ELR25
R36	Resistor	6.8K	ELR25
R37	Resistor	4.7K	ELR25
R38	Resistor	680	ELR25
R39	Resistor	1K	ELR25
R40	Resistor	100	ELR25
R41	Trimmer	4.7K	H0651A
R42	Trimmer	470	H0651A
R43	Resistor	820	ELR25
R45	Resistor	3.3K	ELR25
R46	Resistor	100	ELR25
R47	Resistor	100	ELR25
R49	Resistor	100	ELR25
R50	Resistor	100K	ELR25
R51	Resistor	100K	ELR25
R52	Resistor	1K	ELR25
R53	Resistor	1K	ELR25
R54	Resistor	56K	ELR25
R55	Resistor	100K	ELR25
R56	Resistor	3.3K	ELR25
R57	Resistor	100	R25
R58	Resistor	390	ELR25
R59	Resistor	330	ELR25
R60	Resistor	1K	ELR25
R61	Resistor	4.7K	ELR25
R62	Resistor	10K	ELR25
R63	Resistor	33K	ELR25
R64	Resistor	1K	ELR25
R65	Resistor	47K	ELR25
R66	Trimmer	10K	H0651A
R67	Resistor	10K	ELR25
R68	Resistor	22K	ELR25
R69	Resistor	47K	ELR25
R70	Resistor	2.2K	ELR25

[MAIN] UNIT

REF. NO.	DESCRIPTION	PART NO.
R71	Resistor	3.3M ELR25
R72	Resistor	820K ELR25
R73	Resistor	820K ELR25
R74	Resistor	100K ELR25
R75	Resistor	220 ELR25
R76	Resistor	220 ELR25
R77	Resistor	4.7M ERC14GJ
R78	Resistor	1M ELR25
R79	Resistor	1.8M ELR25
R80	Resistor	10K ELR25
R82	Trimmer	1M H1051C
R83	Resistor	1.8M R25
R84	Resistor	1.8 ELR25
R85	Resistor	22M ERC14GJ
R86	Resistor	10K ELR25
R87	Resistor	100 ELR25
R88	Resistor	3.3M ELR25
R89	Resistor	4.7M ERC14GJ
R90	Resistor	22M ERC14GJ
R91	Trimmer	47K H0651A
R93	Trimmer	10K H0651A
R94	Resistor	22K ELR25
R95	Resistor	22K ELR25
R96	Resistor	3.3M ELR25
R97	Resistor	470K ELR25
R98	Resistor	47K ELR25
R99	Trimmer	10K H0651A
R100	Resistor	100K ELR25
R101	Resistor	4.7K R25
R102	Resistor	470 ELR25
R103	Resistor	100K R25
R104	Resistor	10K ELR25
R105	Resistor	4.7K ELR25
R106	Resistor	330 ELR25
R107	Resistor	22K ELR25
R108	Resistor	4.7K ELR25
R109	Resistor	4.7K ELR25
R110	Resistor	4.7K ELR25
R111	Resistor	330 ELR25
R112	Trimmer	1K H1051C
R113	Resistor	100K ELR25
R114	Resistor	10K ELR25
R115	Resistor	10K ELR25
R116	Resistor	10K ELR25
R117	Resistor	4.7K ELR25
R118	Resistor	4.7K ELR25
R119	Resistor	22K ELR25
R120	Resistor	4.7K ELR25
R121	Resistor	10K ELR25
R122	Resistor	27K R25
R123	Resistor	470 ELR25
R124	Resistor	470 ELR25
R125	Resistor	1M ELR25
R126	Resistor	220K ELR25
R127	Resistor	1M ELR25
R128	Resistor	220K ELR25
R129	Trimmer	1M H1051C
R130	Resistor	47K ELR25
R131	Resistor	47K ELR25
R132	Resistor	10K ELR25
R133	Resistor	100 ELR25
R134	Resistor	820 R25
R135	Resistor	22 ELR25
R136	Resistor	10K ELR25

[MAIN] UNIT

REF. NO.	DESCRIPTION	PART NO.
R137	Trimmer	10K H1051C
R138	Resistor	220 ELR25
R139	Resistor	220K ELR25
R140	Resistor	47K ELR25
R141	Resistor	47K ELR25
R142	Trimmer	10K H1051C
R143	Resistor	47K ELR25
R144	Resistor	2.2K ELR25
R147	Resistor	10 R25
R149	Trimmer	33 H0651A
R150	Trimmer	4.7K H0651A
R151	Trimmer	4.7K H0651A
R152	Resistor	47K ELR10
R153	Resistor	47K R10
R154	Resistor	47K ELR10
R155	Resistor	47K R10
R156	Resistor	47K ELR10
R157	Resistor	1K ELR25
R159	Resistor	4.7K ELR25
R160	Resistor	10 ELR25
R161	Resistor	220 ELR25
R162	Trimmer	10K H1051C
R163	Resistor	4.7K ELR25
R164	Resistor	8.2K ELR25
R166	Resistor	100K ELR25
R167	Resistor	4.7K ELR25
R168	Trimmer	100K H0851
R169	Resistor	10K R25
R170	Resistor	100 R25
R171	Resistor	3.3K R25
R172	Resistor	10K R25
R173	Resistor	4.7K ELR25
R174	Resistor	470 ELR25
C1	Barrier Lay	0.047 25V
C2	Ceramic	0.0047 50V
C3	Ceramic	0.0047 50V
C4	Barrier Lay	0.047 50V
C5	Ceramic	0.0047 50V
C6	Ceramic	0.001 50V
C7	Barrier Lay	0.047 25V
C8	Ceramic	0.0022 50V
C9	Barrier Lay	0.047 25V
C10	Barrier Lay	0.047 25V
C11	Barrier Lay	0.047 25V
C12	Barrier Lay	0.047 25V
C13	Barrier Lay	0.047 25V
C14	Barrier Lay	0.047 25V
C15	Ceramic	390P 50V
C16	Ceramic	390P 50V
C17	Barrier Lay	0.047 25V
C18	Barrier Lay	0.047 25V
C19	Barrier Lay	0.047 25V
C20	Ceramic	0.0047 50V
C21	Ceramic	0.0047 50V
C22	Ceramic	0.0047 50V
C23	Ceramic	0.0047 50V
C24	Ceramic	0.0047 50V
C25	Ceramic	0.001 50V
C26	Ceramic	0.0047 50V
C27	Ceramic	0.001 50V
C28	Ceramic	0.0047 50V
C29	Ceramic	0.0047 50V
C30	Ceramic	0.0047 50V

[MAIN] UNIT

REF. NO.	DESCRIPTION	PART NO.	
C31	Ceramic	0.0047	50V
C32	Ceramic	0.001	50V
C33	Electroly.	10	16V
C34	Ceramic	0.0047	50V
C35	Ceramic	0.0047	50V
C36	Ceramic	22P	50V
C37	Dip Mica	47	50V
C38	Dip Mica	510	50V
C39	Ceramic	82P UJ	50V
C40	Ceramic	0.0047	50V
C41	Barrier Lay	0.047	25V
C42	Electroly.	4.7	16V
C43	Electroly.	0.47	50V
C44	Barrier Lay	0.1	12V
C45	Barrier Lay	0.1	12V
C47	Ceramic	0.0047	50V
C48	Electroly.	470	10V
C49	Ceramic	0.0047	50V
C50	Electroly.	470	10V
C51	Electroly.	4.7	16V
C52	Electroly.	10	16V
C53	Ceramic	0.0047	50V
C54	Electroly.	0.22	50V
C55	Mylar	0.022	50V
C56	Mylar	0.022	50V
C57	Mylar	0.022	50V
C58	Electroly.	10	16V
C59	Electroly.	100	10V
C60	Barrier Lay	0.1	12V
C61	Electroly.	0.47	50V
C62	Electroly.	0.47	50V
C63	Electroly.	1	50V
C64	Electroly.	10	16V
C65	Electroly.	1	50V
C66	Electroly.	0.47	50V
C67	Electroly.	47	10V
C68	Barrier Lay	0.1	12V
C69	Barrier Lay	0.1	12V
C70	Mylar	0.0022	50V
C71	Electroly.	47	16V
C72	Electroly.	100	10V
C73	Electroly.	470	16V
C74	Electroly.	10	16V
C75	Ceramic	120P RH	50V
C76	Ceramic	120P RH	50V
C77	Ceramic	120P RH	50V
C78	Ceramic	120P RH	50V
C79	Ceramic	270P	50V
C80	Electroly.	47	16V
C81	Electroly.	0.22	50V RC2
C84	Barrier Lay	0.1	
C85	Ceramic	220P	
L1	Coil	LS175	
L2	Coil	LS175	
L3	Coil	LS20	
L4	Coil	LS213	
L5	Coil	LS100	
L6	Coil	LS163	
L7	Coil	LS175	
L8	Coil	LS175	
L9	Coil	LS163	
L10	Coil	LS175	
L11	Coil	LS141A	

[MAIN] UNIT

REF. NO.	DESCRIPTION	PART NO.
L12	Choke	LW15
L13	Coil	102 L4
F11	Mechanical Filter	MF-455-11AZ (or 11GZ)
F12	Ceramic Filter	CFW455HT
F13	Crystal Filter	9M10A (9.0115MHz)
X1	Crystal	HC-43/U 9.4665MHz
S1	Switch	SSS012
S2	Switch	SSS012
S3	Switch	SSS012
S4	Switch	SSS012
B1	P.C. Board	B-476C
J1	Connector	5045-6A
J2	Connector	5045-4A
J3	Connector	5045-4A
J4	Connector	5045-4A
J5	Connector	5045-2A
J6	Connector	5045-10A
J7	Connector	5045-4A
J8	Connector	5045-4A
J12	Connector	5045-4A
J13	Connector	5045-4A
J14	Connector	5045-2A
J15	Connector	5045-2A
J16	Connector	5045-2A
J17	Connector	5045-4A
J18	Connector	5045-4A
J19	Connector	5045-2A
J20	Connector	5045-2A
J21	Connector	5045-2A

[DET]	UNIT	REF. NO.	DESCRIPTION	PART NO.
Q1	Transistor			2SC945P
Q2	Transistor			2SC945P
Q5	Transistor			2SC1636
Q6	Transistor			2SC2458 GR
Q7	Transistor			2SC945P
Q8	Transistor			2SC945P
Q9	Transistor			2SC945P
Q10	Transistor			2SA1015
IC1	IC			NJM4558D
IC2	IC			μPC1037H
D1	Diode			1N60
D2	Diode			1SS53
D4	Diode			1SS53
D5	Diode			1N60
D6	Diode			1SS53
D7	Diode			1SS53
D8	Diode			1SS53
D9	Diode			1SS53
D11	Diode			1SS53
D12	Diode			1SS53
D13	Diode			1SS53
D14	Diode			1SS53
D15	Diode			1SS53
D16	Diode			1SS53
D17	Diode			1SS53
R1	Resistor			4.7K R25
R3	Resistor			22K ELR25
R4	Resistor			100 R25
R8	Resistor			3.3M ELR25
R9	Resistor			47K ELR25
R12	Resistor			1K ELR25
R13	Resistor			4.7K ELR25
R14	Resistor			2.2K ELR25
R15	Resistor			4.7K ELR25
R16	Resistor			47 ELR25
R17	Resistor			47K ELR25
R18	Resistor			100K ELR25
R19	Resistor			10K ELR25
R20	Resistor			10K ELR25
R21	Resistor			10K ELR25
R22	Resistor			10K ELR25
R23	Resistor			10K ELR25
R24	Resistor			10K ELR25
R25	Resistor			10K ELR25
R26	Resistor			22K ELR25
R27	Resistor			22K ELR25
R28	Resistor			100K ELR25
R29	Resistor			100K R10
R30	Resistor			3.3M ELR25
R31	Resistor			10K ELR25
R32	Resistor			10K ELR25
R33	Resistor			1.8M ELR25
R34	Resistor			2.2K ELR25
R36	Resistor			6.8K ELR25
R37	Resistor			6.8K ELR25
R38	Resistor			6.8K R10
R39	Resistor			1K ELR10
R40	Resistor			1K ELR10
R41	Resistor			1K ELR25
R42	Resistor			100K ELR25
R43	Resistor			47K ELR25

[DET]	UNIT	REF. NO.	DESCRIPTION	PART NO.
R44	Trimmer			10K H0615A
R45	Trimmer			10K H0615A
R46	Resistor			3.3K R25
R47	Resistor			4.7K ELR25
R48	Resistor			4.7K ELR25
R49	Resistor			220 ELR25
R50	Resistor			100 R25
R51	Resistor			4.7K R25
R52	Resistor			1K ELR25
R53	Resistor			2.2K ELR25
R54	Resistor			2.2K ELR25
R55	Resistor			10K ELR25
R56	Resistor			10K R25
R57	Resistor			2.2K ELR25
R58	Resistor			15K ELR25
R59	Resistor			10K ELR25
R60	Resistor			10K ELR25
R61	Resistor			3.3K ELR25
R62	Resistor			2.7K ELR25
R63	Resistor			47K R25
C1	Ceramic			100P 50V
C2	Ceramic			0.0047 50V
C3	Ceramic			0.0047 50V
C4	Ceramic			100P 50V
C6	Electroly.			0.47 50V
C7	Electroly.			0.1 12V
C8	Electroly.			10 25V
C9	Ceramic			0.0047 50V
C10	Electroly.			10 50V
C11	Electroly.			4.7 35V RC2
C12	Electroly.			1 10V
C14	Electroly.			4.7 35V RC2
C15	Ceramic			100P 50V
C16	Ceramic			100P 50V
C17	Ceramic			0.0047 50V
C18	Barrier Lay			0.047 25V
C19	Barrier Lay			0.1 12V
C20	Barrier Lay			0.047 25V
C22	Electroly.			4.7 BP 50V
C23	Electroly.			10 25V
C24	Mylar			0.01 50V
C25	Mylar			0.01 50V
C26	Barrier Lay			0.0068 50V
C27	Electroly.			0.1 35V RC2
C28	Electroly.			47 10V
C29	Ceramic			47P 50V
C30	Ceramic			0.0047 50V
C31	Ceramic			0.0047 50V
C32	Electroly.			47 10V
C33	Ceramic			0.001 50V
C34	Ceramic			0.0047 50V
C35	Ceramic			0.0047 50V
C36	Ceramic			0.0047 50V
C37	Ceramic			0.0047 50V
C38	Ceramic			0.0047 50V
C39	Ceramic			56P 50V
C40	Trimmer			CV05E3001
C41	Dip Mica			150P 50V
C42	Dip Mica			150P 50V
C43	Ceramic			0.0047 50V
C44	Ceramic			120P 50V
C45	Electroly.			1 50V
C46	Barrier Lay			0.047 25V

[DET] UNIT

REF. NO.	DESCRIPTION	PART NO.
L1	Coil	LS67
L2	Coil	LS133
L3	Coil	LS212
L4	Coil	LS134
B1	P.C. Board	B-477C
J1	Connector	5045-4A
J2	Connector	5045-4A
J3	Connector	5045-4A
J4	Connector	RT-01T-13B
P1	Connector	5250-10A
P2	Connector	5250-2A
X1	Crystal	HC-43/U 9.0145MHz

[PA] UNIT

REF. NO.	DESCRIPTION	PART NO.	
Q1	Transistor	2SC1971	
Q2	Transistor	2SC1945	
Q3	Transistor	2SC1945	
Q4	Transistor	2SC2097	
Q5	Transistor	2SC2097	
Q6	Transistor	2SD313	
Q7	Transistor	2SC2120	
D1	Diode	MV5	
D2	Diode	MV11	
D4	Diode	GP-08	
D5	Diode	15CD11	
R1	Resistor	220	R25
R2	Resistor	390	R25
R3	Resistor	10	R25
R4	Resistor	100	R25
R5	Resistor	2.2	R25
R7	Resistor	3.3	R25
R8	Resistor	22	R25
R9	Resistor	22	R25
R10	Resistor	120	R50
R11	Resistor	120	R50
R12	Resistor	68	R50
R13	Resistor	2.2 RSF	2B
R14	Resistor	2.2 RSF	2B
R15	Resistor	10	R50
R16	Resistor	10	R50
R17	Resistor	3.3	1W
R18	Resistor	3.3	1W
R19	Resistor	10	R50
R20	Resistor	220	R25
R21	Trimmer	500	FR10
R22	Resistor	47	1W
R23	Resistor	22	R25
R24	Resistor	2.2K	R25
R25	Resistor	1.8	R25
R26	Resistor	100	FR10
C1	Ceramic	0.0022	50V
C2	Barrier Lay	0.0012	50V
C3	Ceramic	100P	50V
C4	Barrier	0.1	50V
C5	Mylar	0.01	50V
C6	Mylar	0.01	50V
C7	Cylinder	100P	50V
C8	Barrier Lay	0.1	12V
C9	Monolythic	6800P	50V
C10	Monolythic	6800P	50V
C11	Ceramic	470P SL	50V
C12	Ceramic	470P SL	50V
C13	Ceramic	470P SL	50V
C14	Ceramic	220P	500V
C15	Ceramic	220P	500V
C16	Ceramic	330P	500V
C17	Ceramic	39P	500V
C18	Electroly.	1000	16V
C19	Electroly.	220	16V
C20	Barrier Lay	0.1	50V
C21	Ceramic	0.0047	50V
C22	Electroly.	10	16V
C23	Electroly.	470	16V
C24	Barrier Lay	0.1	12V
C25	Barrier Lay	0.1	12V

[PA] UNIT

REF. NO.	DESCRIPTION	PART NO.	
C26	Barrier Lay	0.1	12V
C27	Barrier Lay	0.1	12V
L1	Choke	LW-22	
L2	Trans	LR117	
L3	Choke	LW18	
L4	Trans	LR113	
L5	Choke	LW18	
L6	Choke	LW18	
L7	Trans	LR83	
L8	Trans	LR114	
S1	Thermal	OHD70M	
J1	Connector	LLR-6	
P1	Connector	5250-02A	
P2	Connector	5250-04A	
P3	Connector	5250-04A	
P4	Connector	1545R-1	
P5	Connector	SMF-01T-1.3	
B1	P.C. Board	B-479A	

[FILTER] UNIT

REF. NO.	DESCRIPTION	PART NO.	
D1	Diode	1N60	
D2	Diode	1N60	
D3	Diode	GP08B	
L1	Coil	LA139	
L2	Coil	LR49	
L3	Coil	LR50	
L5	Coil	LR52	
L6	Coil	LR51	
L7	Coil	LR90	
L8	Coil	LR91	
L9	Coil	LR53	
L10	Coil	LR54	
L11	Coil	LR55	
L12	Coil	LR56	
L13	Coil	LR57	
L14	Coil	LR58	
L15	Coil	LR123	
L16	Coil	102	L4
L17	Coil	LA139	
R1	Resistor	68	R25
R3	Resistor	47K	ELR25
R4	Resistor	47K	ELR25
R5	Resistor	47K	ELR25
R6	Resistor	12K	ELR25
R7	Resistor	12K	ELR25
C1	Dip Mica	DM19	680P 500V 1CR
C2	Ceramic	DD31-0-SL	82P 500V02
C3	Dip Mica	DM20	1200P 500V 1CR
C4	Ceramic	DD31-2-SL220P	500V02
C5	Dip Mica	DM19	680P 500V 1CR
C6	Dip Mica	DM19	470P 500V 1CR
C7	Ceramic	DD31-2-SL120P	500V02
C8	Dip Mica	DM19	680P 500V 1CR
C9	Ceramic	DD35-0-SL	39P 500V02
C10	Dip Mica	DM19	390P 500V 1CR
C11	Dip Mica	DM19	390P 500V 1CR
C12	Ceramic	DD38-0-SL	27P 500V02
C13	Dip Mica	DM19	470P 500V 1CR
C14	Ceramic	DD38-0-SL	68P 500V02
C15	Ceramic	DD31-2-SL220P	500V02
C16	Ceramic	DD31-2-SL180P	500V02
C17	Ceramic	DD35-0-SL	18P 500V02
C18	Ceramic	DD31-4-SL330P	500V02
C19	Ceramic	DD36-0-SL	56P 500V02
C20	Ceramic	DD31-0-SL200P	500V02
C21	Ceramic	DD38-0-SL100P	500V02
C22	Ceramic	DD35-0-SL	10P 500V02
C23	Ceramic	DD31-2-SL150P	500V02
C24	Ceramic	DD35-0-SL	39P 500V02
C25	Ceramic	DD31-0-SL150P	500V02
C26	Ceramic	DD35-0-SL	47P 500V02
C27	Ceramic	DD35-0-SL	15P 500V02
C28	Ceramic	DD31-0-SL120P	500V02
C29	Ceramic	DD35-0-SL	27P 500V02
C30	Ceramic	DD38-0-SL100P	500V02
C31	Trimmer	FCV-IZW20X40	
C32	Ceramic	220P	50V
C33	Ceramic	100P	50V
C34	Ceramic	100P	50V
C35	Ceramic	100P	50V
C36	Ceramic	100P	50V

[FILTER] UNIT

REF. NO.	DESCRIPTION	PART NO.	
C37	Electrolytic	220 μ	16V
C38	Ceramic	0.0047	50V
C39	Ceramic	0.0047	50V
B1	P.C. Board	B-478D	
RL1	Relay	SR-202	
J1	Connector	5045-4A	
J3	Connector	5045-4A	
J4	Connector	5045-4A	
P1	Connector	5250-6A	
P2	Connector	5250-6A	
P3	Connector	5250-2A	
S1	Switch	SRY 202C	

[LOGIC] UNIT

REF. NO.	DESCRIPTION	PART NO.	
IC1	IC	μ PD650-80	
IC2	IC	μ PD4071C	
IC3	IC	μ PD4011C	
IC4	IC	TC4013C	
IC5	IC	μ PD4013C	
IC6	IC	μ PD4066C	
IC7	IC	μ PD4030C	
IC8	IC	μ PD4069C	
IC9	IC	μ A78L05ACC	
Q1	Transistor	2SC945	
Q2	Transistor	2SC945	
Q3	Transistor	2SA798	
Q4	Transistor	2SC945	
Q5	Transistor	2SA1048	
D2	Diode	1SS53	
D3	Diode	1SS53	
D4	Diode	1SS53	
D5	Diode	1SS53	
D6	Diode	1SS53	
D7	Diode	1SS53	
D8	Diode	1SS53	
D9	Diode	1SS53	
D10	Diode	1SS53	
D11	Diode	1SS53	
D12	Diode	1SS53	
D13	Diode	1SS53	
D14	Diode	1SS53	
D15	Diode	1SS53	
D16	Diode	1SS53	
D17	Diode	1SS53	
D18	Diode	1SS53	
D20	Diode	1SS53	
D21	Diode	1SS53	
D22	Diode	1N60	
D23	Diode	1N60	
D24	Diode	1N60	
D25	Diode	1N60	
D26	Diode	1SS53	
D27	Diode	1SS53	
D28	Diode	1SS53	
D29	Diode	1SS53	
X1	Ceralock	CSB430A	
R2	Resistor	15	R25
R3	Resistor	4.7K	ELR25
R4	Resistor	100K	ELR25
R6	Resistor	820K	ELR25
R7	Resistor	3.3M	ELR25
R8	Resistor	820K	ELR25
R9	Resistor	47K	ELR25
R10	Resistor	47K	ELR25
R11	Resistor	1M	ELR25
R12	Resistor	220K	ELR25
R13	Resistor	1M	R25
R14	Resistor	220K	R25
R15	Resistor	47K	ELR25
R16	Resistor	10K	ELR25
R17	Resistor	10K	ELR25
R18	Resistor	150K	ELR25
R19	Resistor	100K	ELR25
R20	Resistor	2.7K	ELR25

[LOGIC] UNIT

REF. NO.	DESCRIPTION	PART NO.	
R21	Resistor	100K	ELR25
R22	Resistor	10K	ELR25
R23	Resistor	10K	ELR25
R24	Resistor	47K	ELR25
R25	Resistor	47K	ELR25
R26	Resistor	1M	ELR25
R27	Resistor	47	ELR25
R28	Resistor	100K	ELR25
R29	Resistor	47K	R25
R30	Resistor	22K	ELR25
R31	Resistor	22K	ELR25
R32	Resistor	22K	ELR25
R33	Resistor	22K	ELR25
R34	Resistor	RM4-473K	
R35	Resistor	RM8-222K	
R36	Resistor	800K	CRB25
R37	Resistor	400K	CRB25
R38	Resistor	200K	CRB25
R39	Resistor	100K	CRB25
R40	Resistor	800K	CRB25
R41	Resistor	400K	CRB25
R42	Resistor	200K	CRB25
R43	Resistor	100K	CRB25
R44	Resistor	480K	CRB25
R45	Resistor	100K	ELR25
R46	Resistor	47K	ELR25
R47	Resistor	10K	ELR25
R48	Resistor	47K	ELR25
C1	Barrier Lay	0.1	12V
C2	Barrier Lay	0.1	12V
C3	Barrier Lay	0.1	12V
C4	Barrier Lay	0.1	12V
C5	Cylinder	0.001	50V
C6	Electroly.	470	6.3V
C7	Barrier Lay	0.1	12V
C8	Electroly.	100	10V
C9	Barrier Lay	0.1	12V
C10	Barrier Lay	0.1	12V
C11	Ceramic	0.001	50V
C12	Ceramic	0.001	50V
C13	Ceramic	470P	50V
C14	Ceramic	470P	50V
C15	Ceramic	100P	
C16	Ceramic	100P	
C17	Electroly.	4.7	10V
C18	Electroly.	0.47	50V
C19	Electroly.	0.47	50V
C20	Barrier L.	0.1	12V
C21	Electroly.	100	10V
C22	Ceramic	0.0022	50V
C24	Barrier Lay	0.001	50V
J1	Connector	5045-8A	
J2	Connector	5045-4A	
J3	Connector	5045-6A	
J4	Connector	5045-4A	
J5	Connector	5045-2A	
J6	Connector	5045-4A	
J7	Connector	5045-2A	
J8	Connector	RT-01T-1.3B	
P1	Connector	5250-6A	
P2	Connector	5250-6A	

[LOGIC] UNIT

REF. NO.	DESCRIPTION	PART NO.
B1	P.C. Board	B-488C

[DISPLAY] UNIT

REF. NO.	DESCRIPTION	PART NO.	
IC1	IC	μPD549C	
DS1	FIP	9-BT-12	
Q1	Transistor	2SC1214C	
D1	Diode	1S953	
D2	Diode	1S953	
D3	Zener	WZ040	
D4	Zener	WZ056	
D5	Diode	1SS53	
D6	Diode	1SS53	
L1	Transformer	LB-119	
P1	Connector	5250-8A	
J1	Connector	5045-2A	
J2	Connector	5045-2A	
R1	Resistor	22	ELR25
R2	Resistor	2.7K	ELR25
R3	Resistor	680	ELR25
R4	Resistor	10K	ELR25
R5	Resistor	RM6-473K	
R6	Resistor	RM8-473K	
R7	Resistor	10	ELR25
R8	Resistor	6.8K	ELR25
R9	Resistor	47K	R25
C1	Electrolytic	47	16V
C2	Ceramic	0.01	50V
C3	Electroly.	47	10V
C4	Electroly.	47	16V
C5	Ceramic	0.001	50V
C6	Electroly.	1000	6.3V
C8	Ceramic	0.0047	50V
B1	P.C. Board	B-487C	

[PLL] UNIT

REF. NO.	DESCRIPTION	PART NO.	
IC1	IC	TC9125P	
IC2	IC	HD10551	
Q1	Transistor	2SC945P	
Q2	Transistor	2SC763C	
Q3	Transistor	2SC763C	
Q4	Transistor	2SC763C	
Q5	Transistor	2SC945P	
Q6	FET	2SK125	
Q7	Transistor	2SC763C	
Q8	Transistor	2SC945P	
D1	Varactor Diode	1SV50	
D2	Varactor Diode	SVC201	
D3	Diode	1SS53	
X1	Crystal	HC-18/U 9.000MHz	
X2	Crystal	HC-18/U 13.666MHz	
R1	Resistor	470K	ELR25
R2	Resistor	100K	ELR25
R3	Resistor	47K	ELR25
R4	Resistor	22K	ELR25
R5	Resistor	10K	ELR25
R6	Resistor	1K	ELR25
R7	Resistor	2.2K	ELR25
R8	Resistor	22K	ELR25
R9	Resistor	4.7K	ELR25
R10	Resistor	2.2K	ELR25
R11	Resistor	22K	R25
R12	Resistor	4.7K	ELR25
R13	Resistor	1K	ELR25
R14	Resistor	220	ELR25
R15	Resistor	100	R25
R16	Resistor	470	ELR25
R17	Resistor	22K	ELR25
R18	Resistor	5.6K	ELR25
R19	Resistor	22K	ELR25
R20	Resistor	4.7K	ELR25
R21	Resistor	100	ELR25
R22	Resistor	470	R25
R23	Resistor	47K	ELR25
R24	Resistor	22K	ELR25
R25	Resistor	680	ELR25
R26	Resistor	330	R25
R27	Resistor	100	R25
R28	Resistor	10K	R25
R29	Resistor	47K	ELR25
R30	Resistor	2.2K	ELR25
R31	Resistor	100K	R25
R32	Resistor	470	R25
R33	Resistor	10K	R25
R34	Resistor	27K	ELR25
R35	Resistor	10K	ELR25
R36	Resistor	2.2K	ELR25
R37	Resistor	1K	ELR25
R38	Resistor	100	ELR25
R39	Resistor	68	ELR25
R40	Resistor	220	ELR25
R41	Resistor	82	ELR25
R42	Resistor	100	ELR25
R43	Resistor	68	R25
C1	Ceramic	0.0047	50V

[PLL] UNIT

REF. NO.	DESCRIPTION	PART NO.	
C2	Ceramic	0.0047	50V
C3	Electroly.	47	10V
C4	Ceramic	0.0047	50V
C5	Dip Mica	220P	50V
C6	Dip Mica	220P	50V
C7	Dip Mica	220P	50V
C8	Ceramic	0.0047	50V
C9	Ceramic	20P	50V
C10	Ceramic	1P	50V
C11	Ceramic	22P	50V
C12	Ceramic	10P	50V
C13	Ceramic	10P	50V
C14	Ceramic	0.0047	50V
C15	Ceramic	0.35	50V
C16	Ceramic	10P	50V
C17	Ceramic	0.0047	50V
C18	Ceramic	220P	50V
C19	Ceramic	0.0047	50V
C20	Cylinder	4.7P	50V
C21	Ceramic	0.0047	50V
C22	Ceramic	0.0047	50V
C23	Ceramic	33P	50V
C24	Ceramic	33P	50V
C25	Ceramic	0.001	50V
C26	Ceramic	0.0047	50V
C27	Ceramic	0.0047	50V
C28	Ceramic	0.0047	50V
C29	Electroly.	47	10V
C30	Ceramic	0.0047	50V
C31	Trimmer	CV05D2001	
C32	Ceramic	18P	50V
C33	Ceramic	20P	50V
C34	Ceramic	470P	50V
C35	Ceramic	0.0022	50V
C36	Electroly.	1	50V
C37	Ceramic	0.0047	50V
C38	Electroly.	47	10V
C39	Ceramic	15P	50V
C40	Ceramic	3P	50V
C41	Ceramic	3P	50V
C42	Ceramic	0.0047	50V
C43	Ceramic	0.0047	50V
C44	Ceramic	1P	50V
C45	Ceramic	0.0047	50V
C46	Ceramic	10P	50V
C47	Cylinder	0.001	50V
C48	Electroly.	470	10V
C49	Ceramic	0.0047	50V
C50	Ceramic	0.001	50V
C51	Ceramic	200P	50V
C52	Electroly.	22	10V
C53	Ceramic	220P	50V
C54	Ceramic	68P	50V
C55	Ceramic	0.0047	50V
C56	Ceramic	470P SL	50V
C57	Ceramic	220P	50V
C58	Barrier Lay	0.047	25V
C59	Ceramic	0.0047	50V
C60	Ceramic	470P	50V
C61	Ceramic	470P	50V
C64	Ceramic	470P	50V
C65	Ceramic	200P	50V
L1	Coil	LS191	

[PLL] UNIT

REF. NO.	DESCRIPTION	PART NO.	
L2	Coil	LS191	
L3	Coil	LS3A	
L4	Coil	LS3A	
L5	Choke	100 (EL0810SKI-100K)	
L6	Choke	2R7 (EL0810SKI-2R7)	
L7	Choke	LW19	
L8	Coil	LB113	
L9	Coil	LS3A	
L10	Choke	LS206	
L11	Choke	R70 LB4	
J1	Connector	5045-6A	
J2	Connector	5045-4A	
P1	Connector	5250-2A	
B1	P.C. Board	B-471C	

[PRE MIX] UNIT

REF. NO.	DESCRIPTION	PART NO.	
Q1	Transistor	2SC945P	
Q2	Transistor	2SC945P	
Q3	Transistor	2SC945P	
Q4	Transistor	2SC945P	
Q5	Transistor	2SC945P	
Q6	Transistor	2SC945P	
Q7	Transistor	2SC945P	
Q8	Transistor	2SC945P	
Q9	Transistor	2SC945P	
Q10	Transistor	2SC945P	
Q11	Transistor	2SC945P	
D1	Diode	1SS99	
D2	Diode	1SS99	
D3	Diode	1SS99	
D4	Diode	1SS99	
D5	Diode	1SS53	
D6	Diode	1SS53	
D7	Diode	1SS53	
D8	Diode	1SS53	
D9	Diode	1SS53	
D10	Diode	1SS53	
D11	Diode	1SS53	
D12	Diode	1SS53	
D13	Diode	1SS53	
D14	Diode	1SS53	
D15	Diode	1SS53	
D16	Diode	1SS53	
D17	Diode	1SS53	
D18	Diode	1SS53	
D19	Diode	1SS53	
D20	Diode	1SS53	
D21	Diode	1SS53	
D22	Diode	1SS53	
D23	Diode	1SS53	
D24	Diode	1SS53	
D25	Diode	1SS53	
D26	Diode	1SS53	
D27	Diode	1SS53	
D28	Diode	1SS53	
D29	Diode	1SS53	
D30	Diode	1SS53	
D31	Diode	1SS53	
D32	Diode	1SS53	
D33	Diode	1SS53	
D34	Diode	1SS53	
D35	Diode	1SS53	
D36	Diode	1SS53	
D37	Diode	1SS53	
X1	Crystal	HC-18/U 29.9315MHz	
X2	Crystal	HC-18/U 33.4315MHz	
X3	Crystal	HC-18/U 36.4315MHz	
X4	Crystal	HC-18/U 40.4315MHz	
X5	Crystal	HC-18/U 44.4315MHz	
X6	Crystal	HC-18/U 47.4315MHz	
X7	Crystal	HC-18/U 50.9315MHz	
X8	Crystal	HC-18/U 54.4315MHz	
X9	Crystal	HC-18/U 54.9315MHz	
X10	Crystal	HC-18/U 55.4315MHz	
X11	Crystal	HC-18/U 55.9315MHz	
R1	Resistor	4.7K	ELR25
R2	Resistor	22K	ELR25

[PRE MIX] UNIT

REF. NO.	DESCRIPTION	PART NO.	
R3	Resistor	470	ELR25
R4	Resistor	100	ELR25
R5	Resistor	4.7K	ELR25
R6	Resistor	22K	ELR25
R7	Resistor	470	ELR25
R8	Resistor	100	ELR25
R9	Resistor	4.7K	ELR25
R10	Resistor	22K	ELR25
R11	Resistor	470	ELR25
R12	Resistor	100	ELR25
R13	Resistor	4.7K	ELR25
R14	Resistor	22K	ELR25
R15	Resistor	470	ELR25
R16	Resistor	100	ELR25
R17	Resistor	4.7K	ELR25
R18	Resistor	22K	ELR25
R19	Resistor	390	ELR25
R20	Resistor	100	ELR25
R21	Resistor	4.7K	ELR25
R22	Resistor	22K	ELR25
R23	Resistor	390	ELR25
R24	Resistor	100	R25
R25	Resistor	4.7K	ELR25
R26	Resistor	22K	ELR25
R27	Resistor	390	ELR25
R28	Resistor	100	ELR25
R29	Resistor	4.7K	ELR25
R30	Resistor	22K	ELR25
R31	Resistor	390	ELR25
R32	Resistor	100	ELR25
R33	Resistor	4.7K	ELR25
R34	Resistor	22K	ELR25
R35	Resistor	390	ELR25
R36	Resistor	100	ELR25
R37	Resistor	4.7K	ELR25
R38	Resistor	22K	ELR25
R39	Resistor	390	ELR25
R40	Resistor	100	ELR25
R41	Resistor	4.7K	ELR25
R42	Resistor	22K	ELR25
R43	Resistor	390	ELR25
R44	Resistor	100	ELR25
R46	Resistor	47	R25
R47	Resistor	120	ELR25
R48	Resistor	33	ELR25
C1	Ceramic	120P	50V
C2	Ceramic	0.0047	50V
C3	Ceramic	0.0047	50V
C4	Ceramic	100P	50V
C5	Ceramic	0.0047	50V
C6	Ceramic	0.0047	50V
C7	Ceramic	68P	50V
C8	Ceramic	0.0047	50V
C9	Ceramic	0.0047	50V
C10	Ceramic	68P	50V
C11	Ceramic	0.0047	50V
C12	Ceramic	0.0047	50V
C13	Ceramic	56P	50V
C14	Ceramic	0.0047	50V
C15	Ceramic	0.0047	50V
C16	Ceramic	47P	50V
C17	Ceramic	0.0047	50V
C18	Ceramic	0.0047	50V

[PRE MIX] UNIT

REF. NO.	DESCRIPTION	PART NO.
C19	Ceramic	43P 50V
C20	Ceramic	0.0047 50V
C21	Ceramic	0.0047 50V
C22	Ceramic	36P 50V
C23	Ceramic	0.0047 50V
C24	Ceramic	0.0047 50V
C25	Ceramic	36P 50V
C26	Ceramic	0.0047 50V
C27	Ceramic	0.0047 50V
C28	Ceramic	36P 50V
C29	Ceramic	0.0047 50V
C30	Ceramic	0.0047 50V
C31	Ceramic	36P 50V
C32	Ceramic	0.0047 50V
C33	Ceramic	0.0047 50V
C34	Electroly	10 μ 16V
C35	Ceramic	0.0047 50V
C36	Ceramic	0.0047 50V
C37	Ceramic	0.0047 50V
C38	Barrier Lay	0.047 25V
C39	Barrier Lay	0.047 25V
C40	Barrier Lay	0.047 25V
C41	Barrier Lay	0.047 25V
C42	Barrier Lay	0.047 25V
C43	Barrier Lay	0.047 25V
C44	Barrier Lay	0.047 25V
C45	Barrier Lay	0.047 25V
C46	Barrier Lay	0.047 25V
C47	Barrier Lay	0.047 25V
C48	Ceramic	0.0047 50V
C49	Ceramic	0.0047 50V
C50	Ceramic	0.0047 50V
C51	Ceramic	0.0047 50V
C52	Ceramic	0.0047 50V
C53	Ceramic	0.0047 50V
C54	Barrier Lay	0.047 25V
C55	Ceramic	0.0047 50V
C56	Ceramic	0.0047 50V
C57	Barrier Lay	0.047 25V
L1	Coil	LS193
L2	Coil	LS193
L3	Coil	LS193
L4	Coil	LS193
L5	Coil	LS193
L6	Coil	LS193
L7	Coil	LS193
L8	Coil	LS193
L9	Coil	LS193
L10	Coil	LS193
L11	Coil	LS193
L12	Coil	LS116
L13	Coil	LS116
L14	Choke	EL0810SKI-100K
L15	Choke	EL0810SKI-100K
B1	P.C. Board	B-472C
J1	Connector	5045-8A
J2	Connector	5045-10A
J3	Connector	5045-6A
J4	Connector	5045-6A
J5	Connector	5045-2A
J6	Connector	5045-6A

[PRE MIX] UNIT

REF. NO.	DESCRIPTION	PART NO.
J7	Connector	5045-2A
J8	Connector	5045-2A

[BPF] UNIT

REF. NO.	DESCRIPTION	PART NO.	
Q1	Transistor	2SC763	
Q2	Transistor	2SC763	
Q3	Transistor	2SC2053	
D1	Diode	1SS53	
D2	Diode	1SS53	
D3	Diode	1SS53	
D4	Diode	1SS53	
D5	Diode	1SS53	
D6	Diode	1SS53	
D7	Diode	1SS53	
D8	Diode	1SS53	
D9	Diode	1SS53	
D10	Diode	1SS53	
D11	Diode	1SS53	
D12	Diode	1SS53	
D13	Diode	1SS53	
D14	Diode	1SS53	
D15	Diode	1SS53	
D16	Diode	1SS53	
R1	Resistor	1K	ELR25
R2	Resistor	2.2K	ELR25
R3	Resistor	1K	ELR25
R4	Resistor	2.2K	ELR25
R5	Resistor	1K	ELR25
R6	Resistor	2.2K	ELR25
R7	Resistor	1K	ELR25
R8	Resistor	2.2K	ELR25
R9	Resistor	1K	ELR25
R10	Resistor	2.2K	ELR25
R11	Resistor	1K	ELR25
R12	Resistor	2.2K	ELR25
R13	Resistor	1K	ELR25
R14	Resistor	2.2K	ELR25
R15	Resistor	1K	ELR25
R16	Resistor	2.2K	ELR25
R17	Resistor	2.2K	ELR25
R18	Resistor	1K	ELR25
R19	Resistor	2.2K	ELR25
R20	Resistor	10K	ELR25
R21	Resistor	1K	ELR25
R22	Resistor	680	ELR25
R23	Resistor	470	ELR25
R24	Resistor	22	ELR25
R25	Resistor	3.3K	ELR25
R26	Resistor	100	ELR25
C1	Ceramic	120P	50V
C2	Ceramic	22P	50V
C3	Ceramic	56P	50V
C3	Ceramic	100P	50V
C5	Ceramic	62P	50V
C6	Ceramic	24P	50V
C7	Ceramic	120P	50V
C9	Ceramic	47P	50V
C10	Ceramic	51P	50V
C11	Ceramic	68P	50V
C12	Ceramic	15P	50V
C13	Ceramic	62P	50V
C14	Barrier Lay	0.047	25V
C15	Barrier Lay	0.047	25V
C16	Ceramic	0.0047	50V
C17	Ceramic	39P	50V

[BPF] UNIT

REF. NO.	DESCRIPTION	PART NO.	
C18	Ceramic	1P	50V
C19	Ceramic	39P	50V
C20	Ceramic	0.0047	50V
C21	Barrier Lay	0.047	25V
C22	Ceramic	0.0047	50V
C23	Ceramic	33P	50V
C24	Ceramic	0.75P	50V
C25	Ceramic	33P	50V
C26	Ceramic	0.0047	50V
C27	Barrier Lay	0.047	25V
C28	Ceramic	0.0047	50V
C29	Ceramic	30P	50V
C30	Ceramic	0.75P	50V
C31	Ceramic	30P	50V
C32	Ceramic	0.0047	50V
C33	Barrier Lay	0.047	25V
C34	Ceramic	0.0047	50V
C35	Ceramic	27P	50V
C36	Ceramic	0.75P	50V
C37	Ceramic	27P	50V
C38	Ceramic	0.0047	50V
C39	Barrier Lay	0.047	25V
C40	Ceramic	0.0047	50V
C41	Ceramic	24P	50V
C42	Ceramic	0.5P	50V
C43	Ceramic	24P	50V
C44	Ceramic	0.0047	50V
C45	Barrier Lay	0.047	25V
C46	Ceramic	0.0047	50V
C47	Ceramic	22P	50V
C48	Ceramic	0.5P	50V
C49	Ceramic	22P	50V
C50	Ceramic	0.0047	50V
C51	Barrier Lay	0.047	25V
C52	Ceramic	0.0047	50V
C53	Ceramic	18P	50V
C54	Ceramic	0.5P	50V
C55	Ceramic	18P	50V
C56	Ceramic	0.0047	50V
C57	Barrier Lay	0.047	25V
C58	Ceramic	0.0047	50V
C59	Ceramic	15P	50V
C60	Ceramic	0.75P	50V
C61	Ceramic	15P	50V
C62	Ceramic	0.0047	50V
C63	Cylinder	47P	50V
C64	Ceramic	33P	50V
C65	Ceramic	0.0047	50V
C66	Barrier Lay	0.047	25V
C67	Ceramic	0.0047	50V
C68	Ceramic	330P	50V
C69	Barrier Lay	0.0015	50V
C70	Ceramic	330P	50V
L1	Coil	LS-201	
L2	Coil	LS-202	
L3	Coil	LS-134	
L4	Coil	LS-204	
L5	Coil	LS-205	
L6	Coil	LS-192	
L7	Coil	LS-192	
L8	Coil	LS-192	
L9	Coil	LS-192	
L10	Coil	LS-192	

[BPF] UNIT

REF. NO.	DESCRIPTION	PART NO.
L11	Coil	LS-192
L12	Coil	LS-192
L13	Coil	LS-192
L14	Coil	LS-192
L15	Coil	LS-192
L16	Coil	LS-192
L17	Coil	LS-192
L18	Coil	LS-192
L19	Coil	LS-192
L20	Coil	LS-192
L21	Coil	LS-192
L22	Coil	LR-85A
L23	Coil	LS-208
P1	Connector	5250-10A
P2	Connector	5250-02A
P3	Connector	5250-02A
B1	P.C. Board	B-473C

[SENSOR] UNIT

REF. NO.	DESCRIPTION	PART NO.	
IC1	Photo. Int.	ON1105	
IC2	Photo. Int.	ON1105	
R1	Resistor	330	R25
R2	Trimmer	RGP056	30K
R3	Trimmer	RGP056	30K
P1	Connector	5250-4A	
B1	P.C. Board	B-492	

[REGULATOR] UNIT

REF. NO.	DESCRIPTION	PART NO.	
IC1	IC	MB3756	
Q1	Transistor	2SD313	
D1	Diode	GP08B	
D2	Diode	GP08B	
R1	Resistor	4.7	ELR25
R2	Resistor	220	ELR25
R3	Trimmer	RGP053	10K
C1	Electroly.	470	16V
C2	Electroly.	4.7	10V
C3	Electroly.	22	10V
C4	Electroly.	47	10V
C5	Electroly.	100	10V
B1	P.C. Board	B-482A	

[ACC] UNIT

REF. NO.	DESCRIPTION	PART NO.	
R1	Resistor	220	ELR25
R3	Resistor	220	ELR25
R5	Resistor	220	ELR25
R6	Resistor	220	ELR25
R7	Resistor	15	ELR25
D1	Diode	1SS53	
D2	Diode	GP-08B	
D3	Diode	GP-08B	
C1	Ceramic	0.0047	50V
C2	Ceramic	0.0047	50V
C3	Ceramic	0.0047	50V
C4	Ceramic	0.0047	50V
C5	Ceramic	0.0047	50V
C6	Ceramic	0.0047	50V
C7	Ceramic	0.0047	50V
C8	Ceramic	0.0047	50V
C9	Ceramic	0.0047	50V
C10	Ceramic	0.0047	50V
C11	Ceramic	0.0047	50V
C12	Ceramic	0.0047	50V
C16	Ceramic	0.0047	50V
C17	Ceramic	0.0047	50V
RL1	Relay	BR211AD012M	
J1	Connector	RT-01T-1.3B	
J2	Connector	5045-02A	
J3	Connector	RT-01T-1.3B	
J4	Connector	5045-04A	
J5	Connector	5045-04A	
J6	Connector	5045-04A	
J7	Connector	1625-24R	
J8	Connector	RT-01T-1.3B	
J9	Connector	RT-01T-1.3B	
P1	Connector	SMP-06V-B	
P2	Connector	5250-02A	
P3	Connector	5250-04A	
P5	Connector	SMF-01T-1.3	
P6	Connector	5250-02A	
P7	Connector	5250-04A	
P8	Connector	SMF-01T-1.3	
B1	P.C. Board	B-481D	
FH1	Fuse Holder	SN11-2	
F1	Fuse	5A	

IC-730S SCHEMATIC DIAGRAM

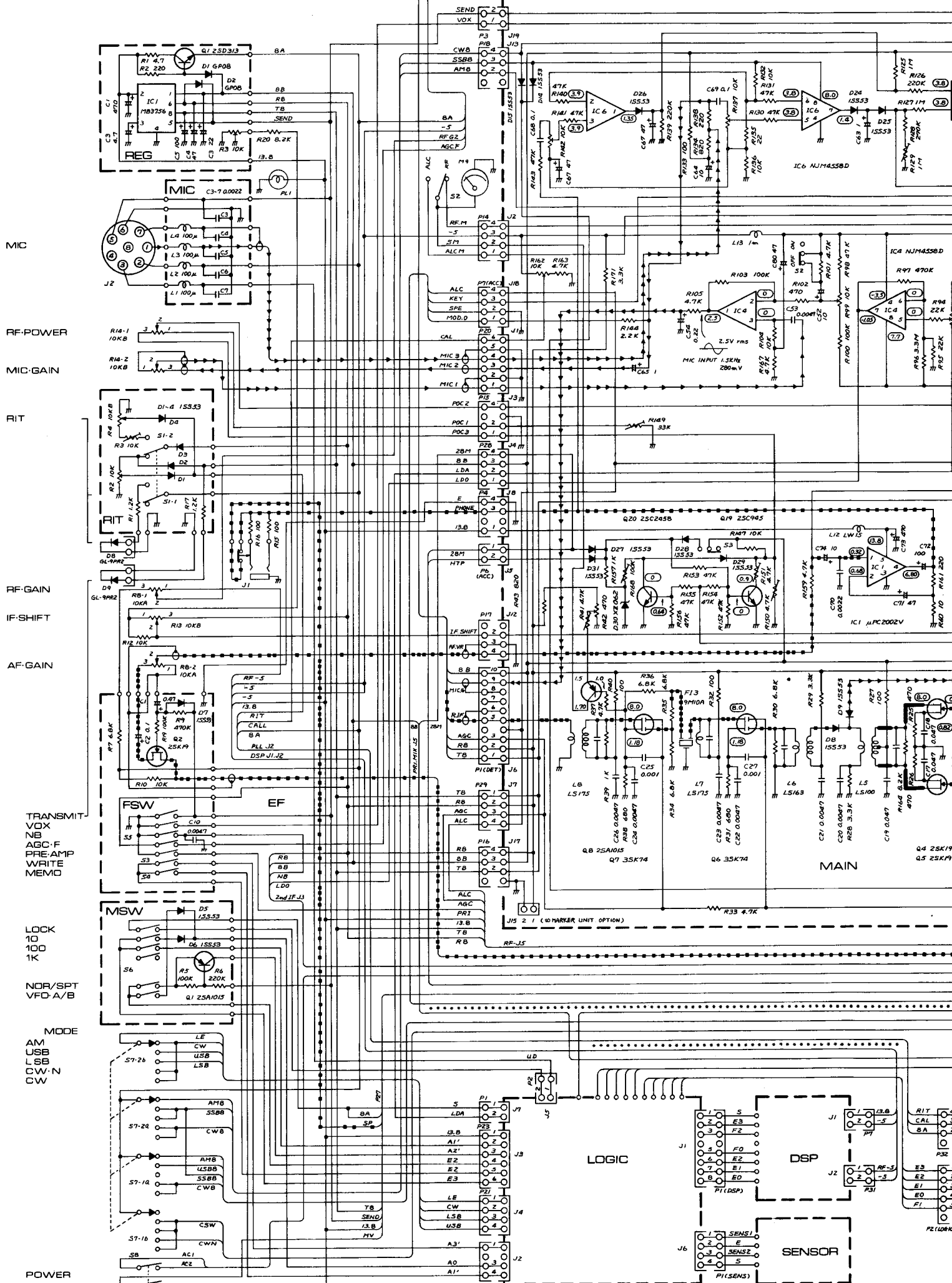

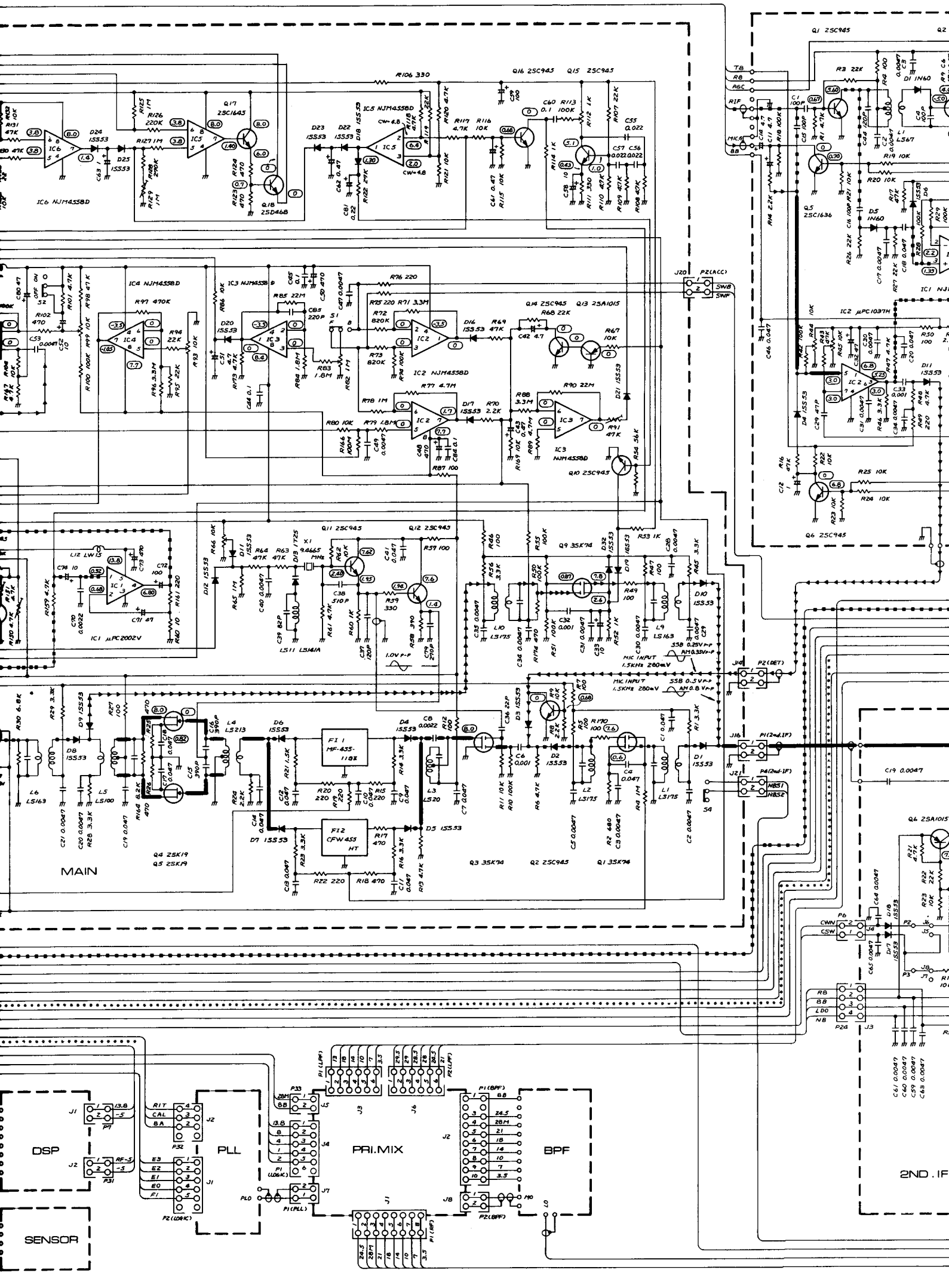

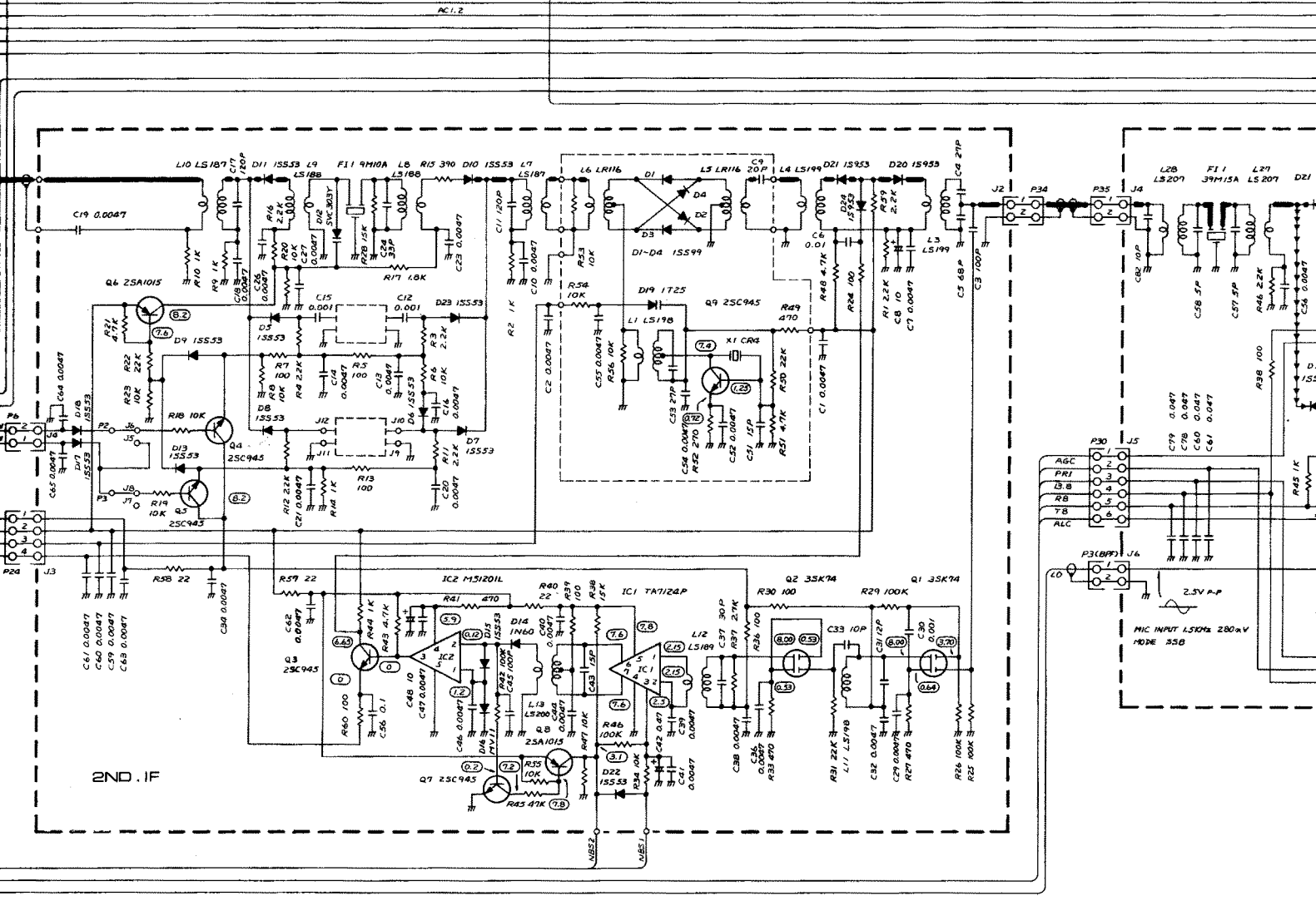
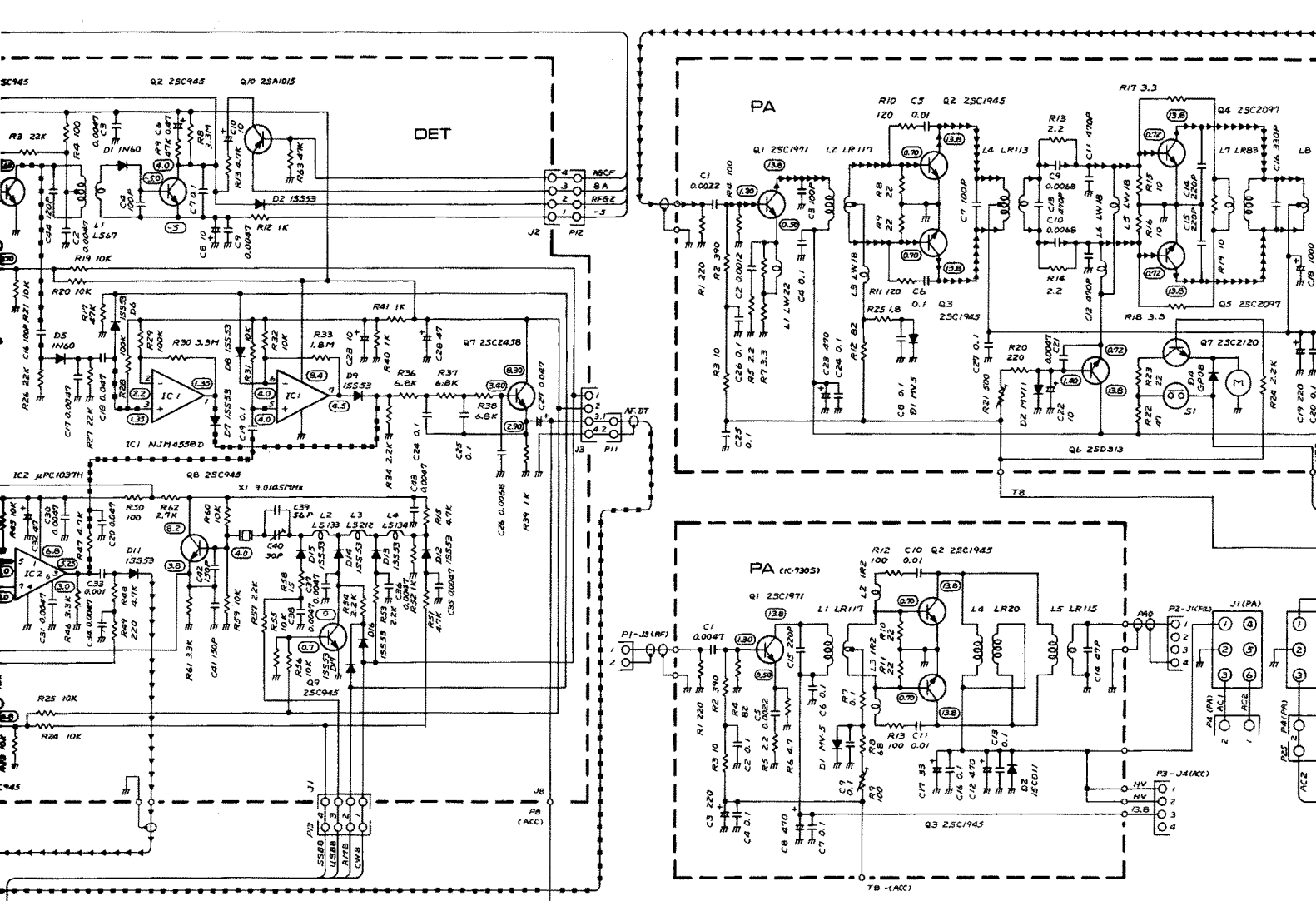

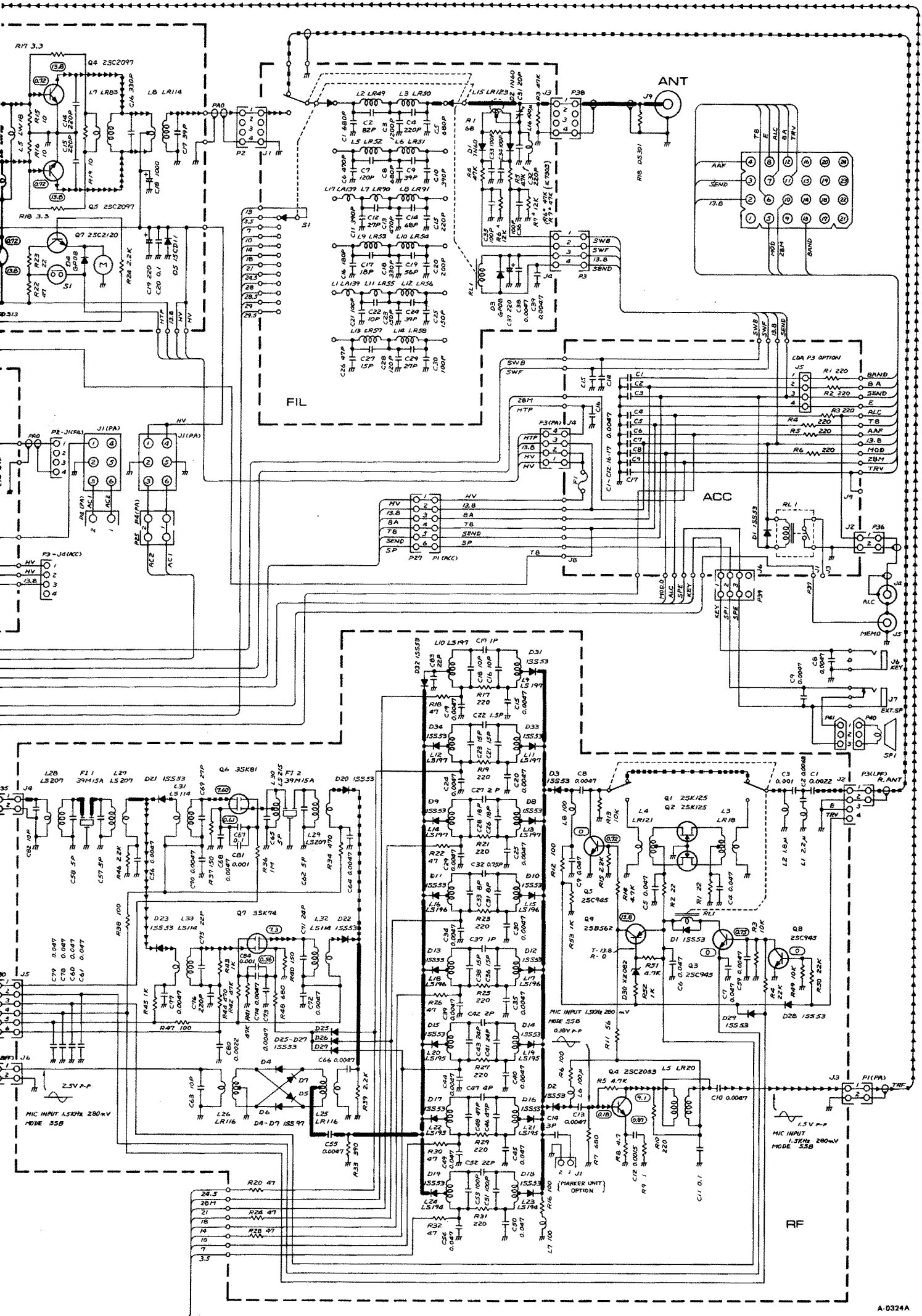

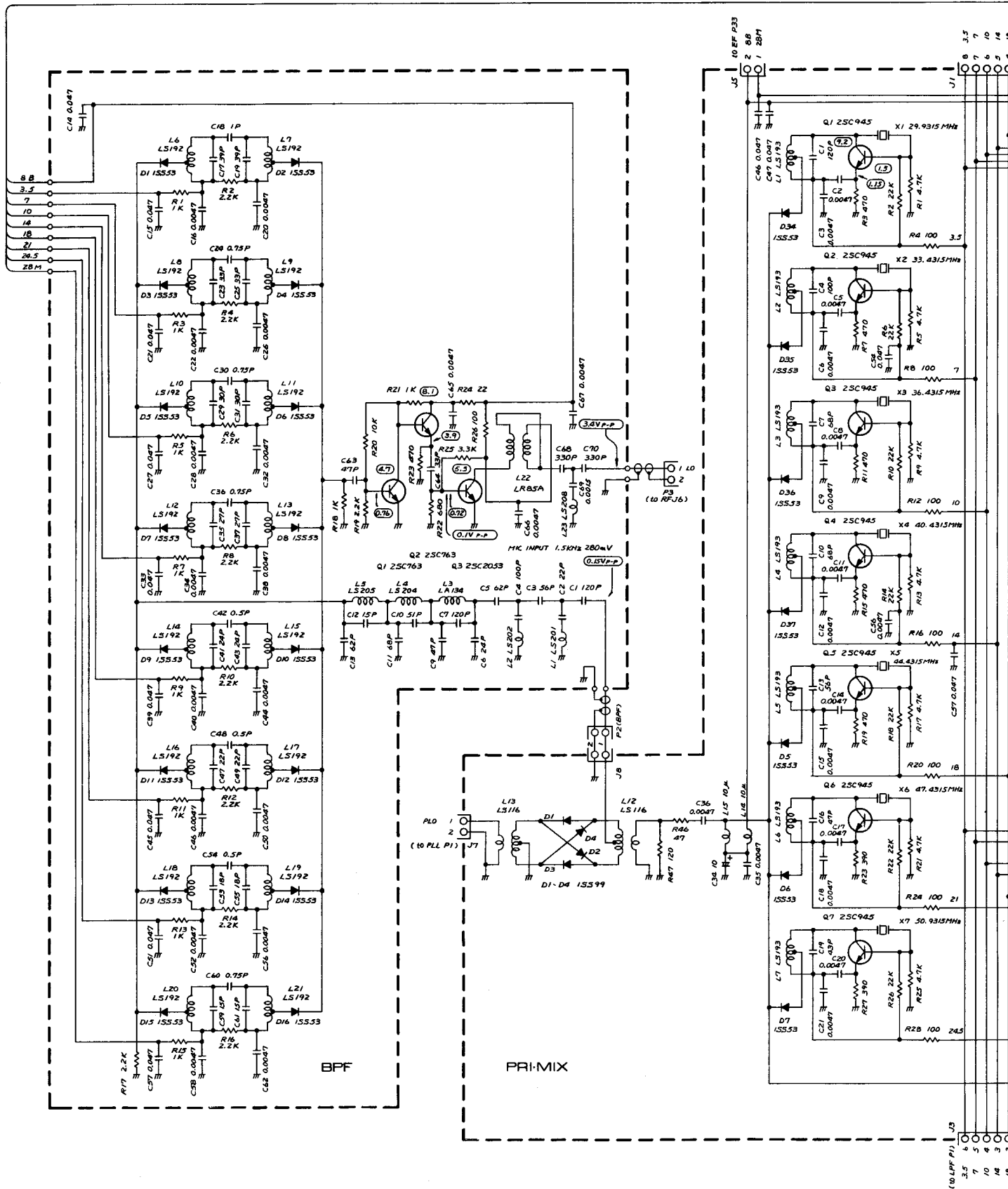

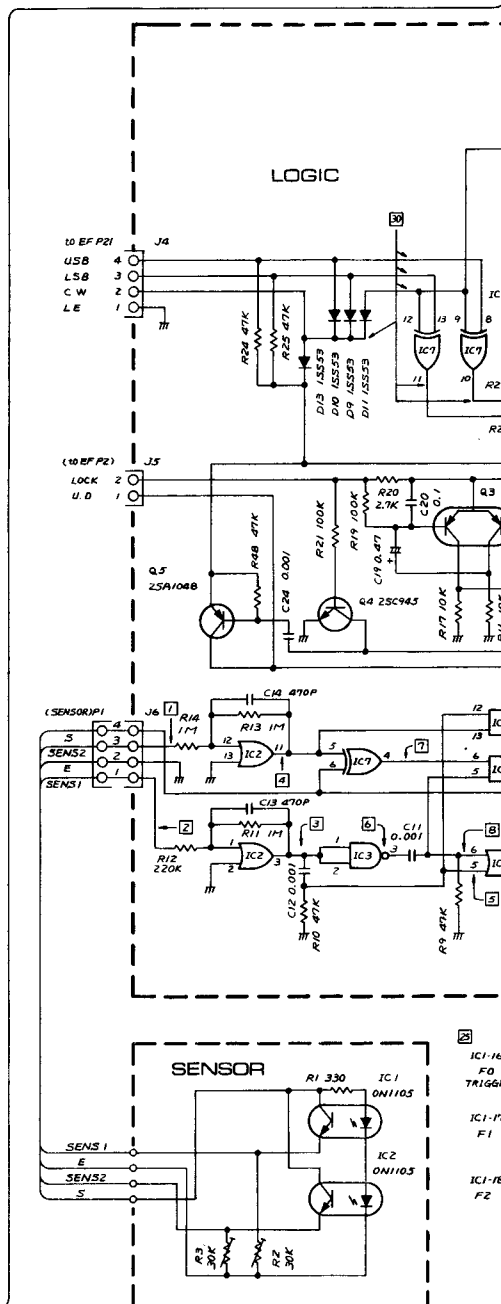
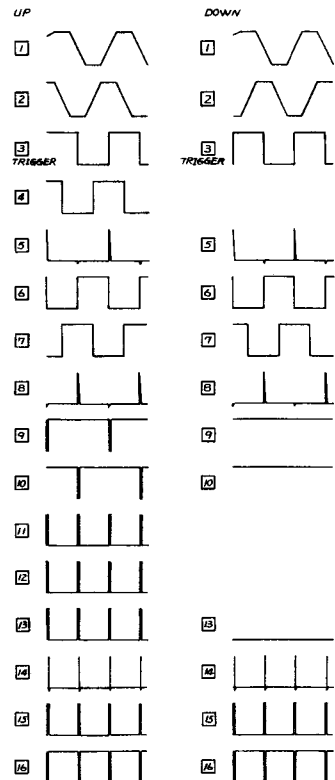
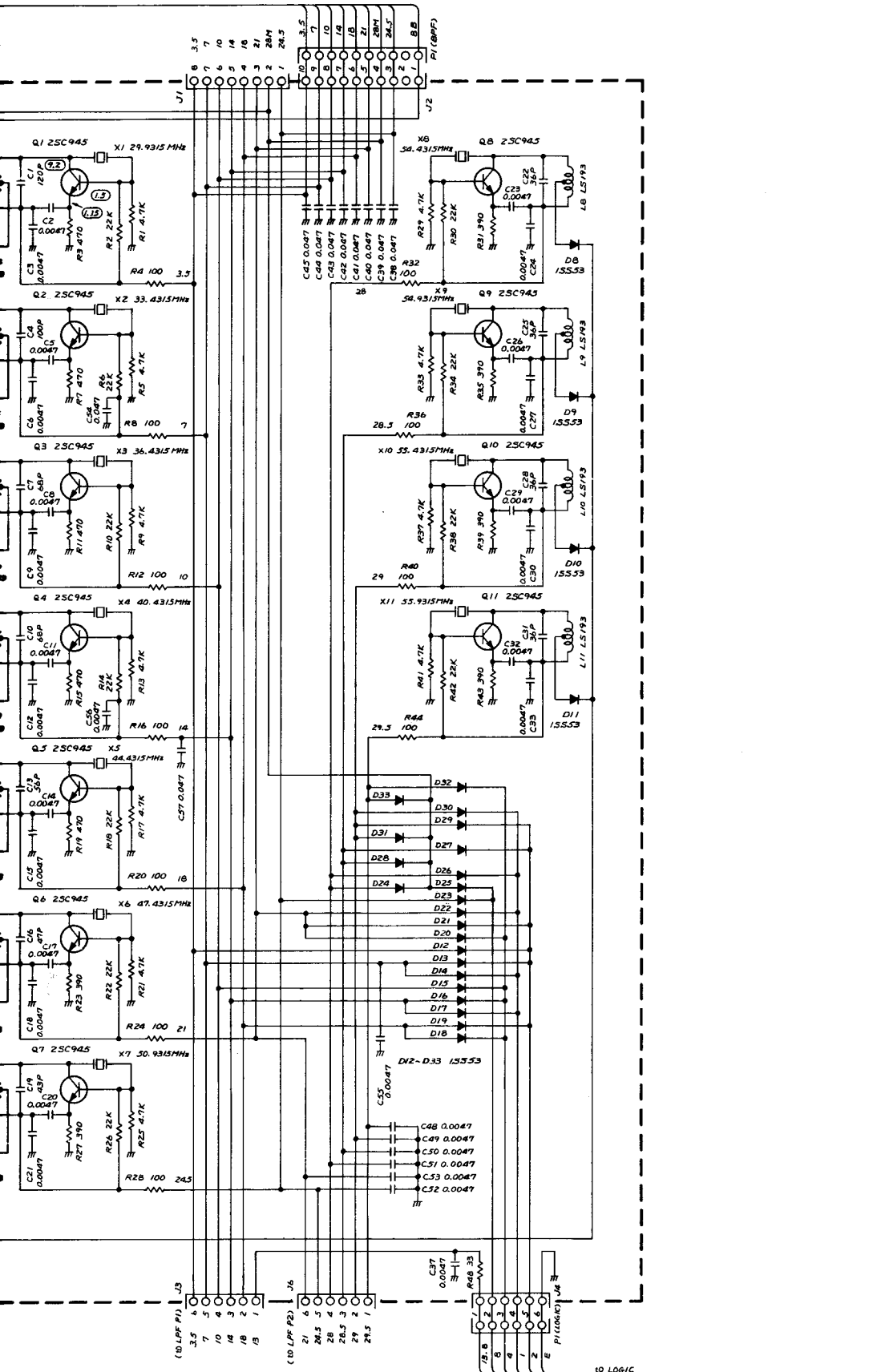

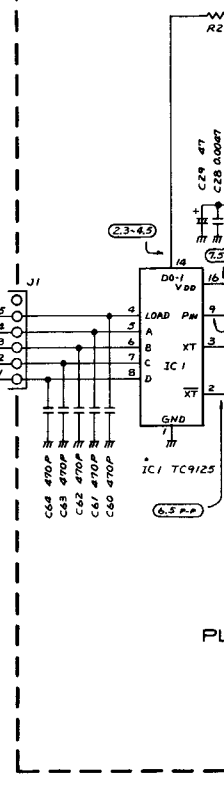
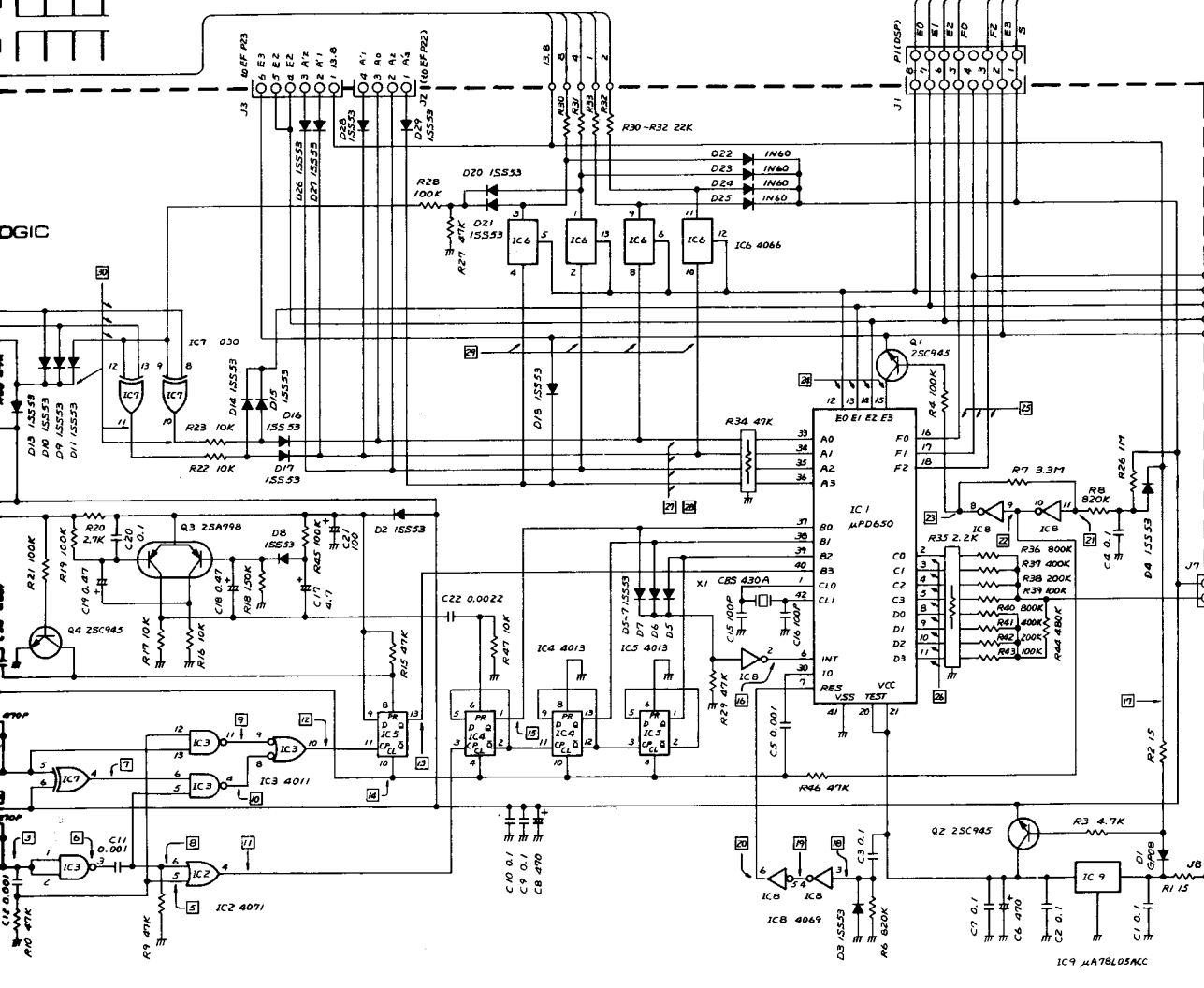
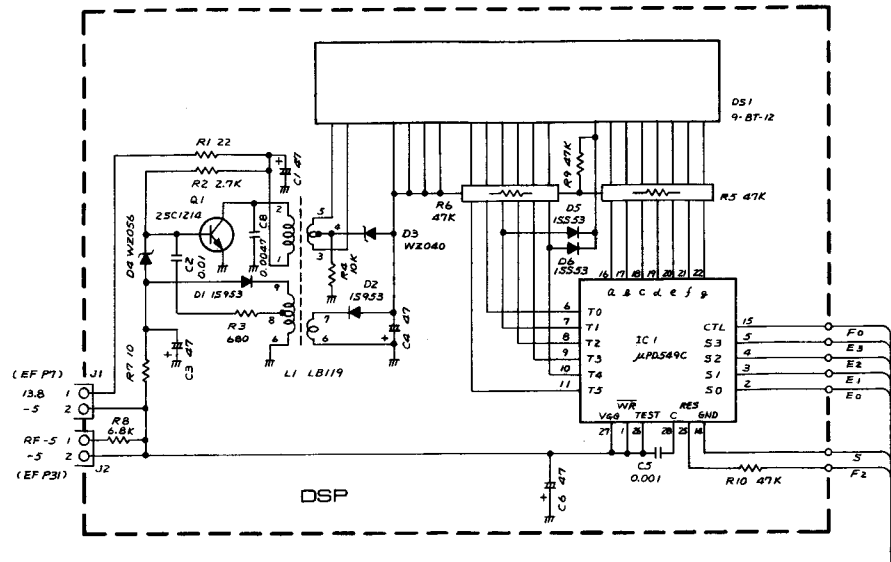
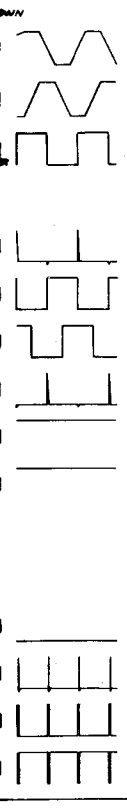

IC1 D/A DATA OUT

FREQUENCY	PM	2	3	4	5
0.00 KHZ	L	L	L	L	L
0.01	L	L	L	L	L
0.02	L	L	L	L	L
0.03	L	L	L	L	L
0.04	L	L	L	L	L
0.05	L	L	L	L	L
0.06	L	L	L	L	L
0.07	L	L	L	L	L
0.08	L	L	L	L	L
0.09	L	L	L	L	L
0.10	H	L	L	L	L
0.11	H	L	L	L	L
0.12	H	L	L	L	L
0.13	H	L	L	L	L
0.95	H	L	L	L	H
0.96	H	L	L	L	H
0.97	H	L	L	L	H
0.98	H	L	L	L	H
0.99	H	L	L	L	H
1.00	L	L	L	L	L
0.0 KHZ	L	L	L	L	L
0.1	H	L	L	L	L
0.2	H	L	L	L	L
0.3	H	L	L	L	L
0.4	L	L	L	L	L
0.5	H	L	L	L	L
0.6	L	L	L	L	L
0.7	H	L	L	L	L
0.8	L	L	L	L	L
0.9	H	L	L	L	L
1.0	L	L	L	L	L

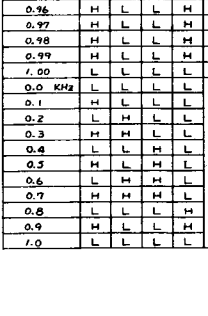
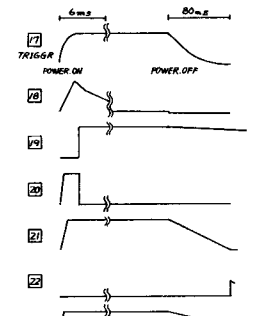
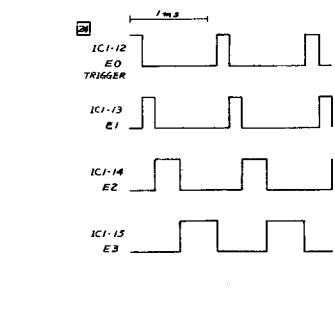
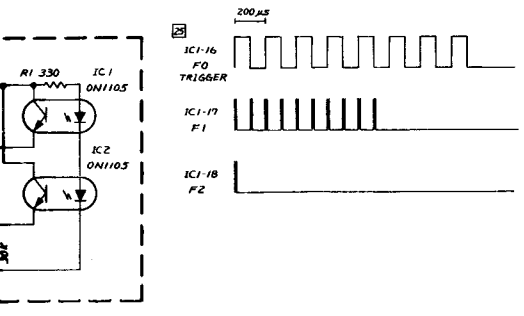

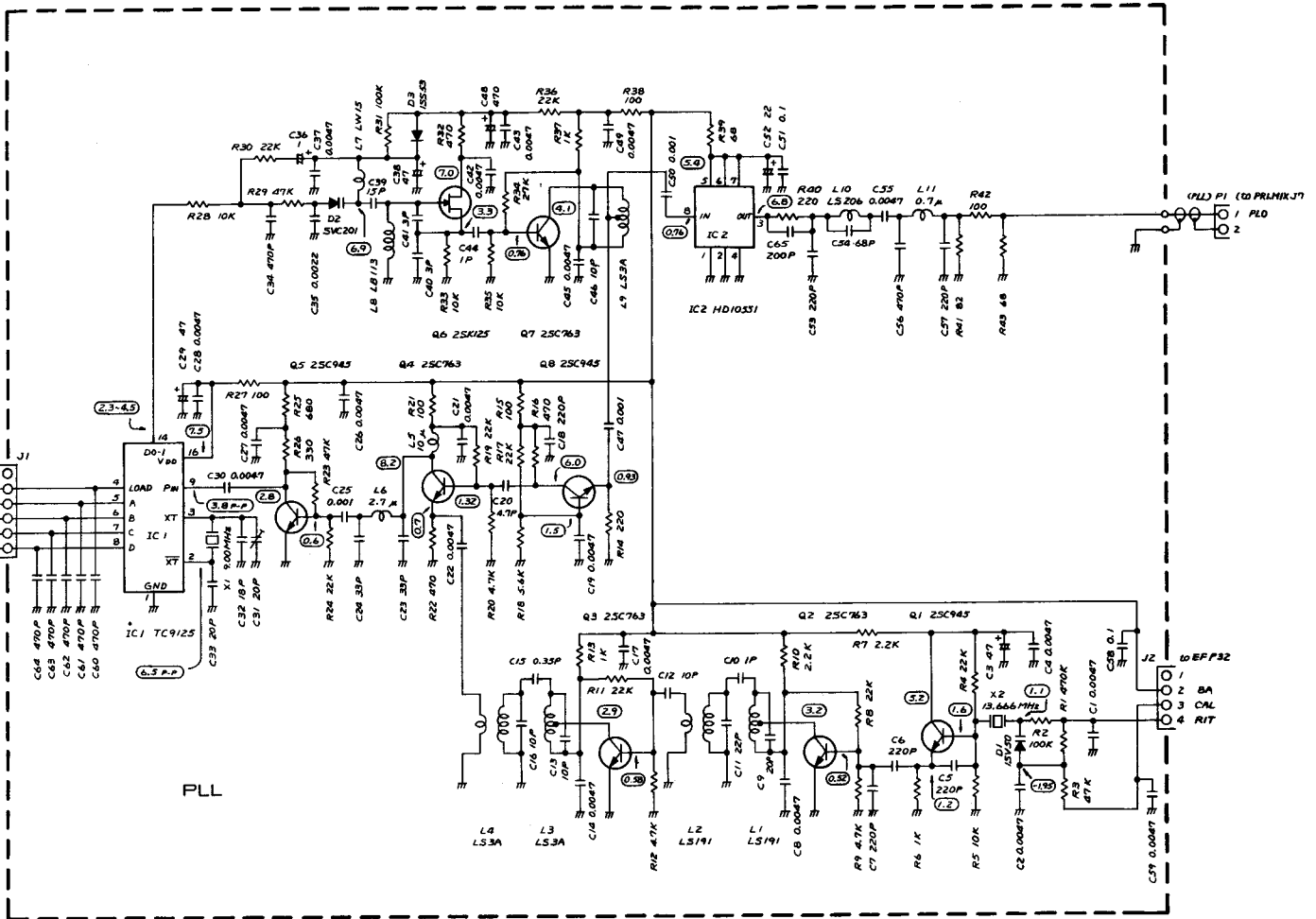

IC1 D/A DATA OUT

FREQUENCY	PM	2	3	4	5	8	9	10	11
	Co	C1	C2	C3	D0	D1	D2	D3	D4
0.00 KHz	L	L	L	L	L	L	L	L	L
0.01	L	L	L	L	L	L	L	L	L
0.02	L	L	L	L	L	L	L	L	L
0.03	L	L	L	L	L	L	L	L	L
0.04	L	L	L	L	L	L	L	L	L
0.05	L	L	L	L	L	L	L	L	L
0.06	L	L	L	L	L	L	L	L	L
0.07	L	L	L	L	L	L	L	L	L
0.08	L	L	L	L	L	L	L	L	L
0.09	L	L	L	L	L	L	L	L	L
0.10	H	L	L	L	L	L	L	L	L
0.11	H	L	L	L	L	L	L	L	L
0.12	H	L	L	L	L	L	L	L	L
0.13	H	L	L	L	L	L	L	L	L
0.95	H	L	L	L	L	L	L	L	L
0.96	H	L	L	L	L	L	L	L	L
0.97	H	L	L	L	L	L	L	L	L
0.98	H	L	L	L	L	L	L	L	L
0.99	H	L	L	L	L	L	L	L	L
1.00	L	L	L	L	L	L	L	L	L
0.0 KHz	L	L	L	L	L	L	L	L	L
0.1	H	L	L	L	L	L	L	L	L
0.2	L	H	L	L	L	L	L	L	L
0.3	H	L	L	L	L	L	L	L	L
0.4	L	L	H	L	L	L	L	L	L
0.5	L	L	L	H	L	L	L	L	L
0.6	L	L	L	L	H	L	L	L	L
0.7	L	L	L	L	L	H	L	L	L
0.8	L	L	L	L	L	L	H	L	L
0.9	H	L	L	L	L	L	L	H	L
1.0	L	L	L	L	L	L	L	L	H

VFO MEMORY

	IC1-PM	33	34	35	36
	A0	A1	A2	A3	A4
VFO	A	L	L	L	L
B	H	L	L	L	L
MEMORY	OFF	L	L	L	L
ON		H	L	L	L
NDR		L	L	L	L
SPT		L	L	L	L
WRITE	OFF	L	L	L	L
ON		H	L	L	L

MODE SW

BAND	MODE	J4	J4	J4	IC7	IC7	IC7	IC7	IC7
		-2	-3	-4	-8	-9	-13	-10	-11
3.5 MHz	CW	L	L	L	L	L	L	L	L
-7 MHz	LSB	H	L	H	L	L	L	L	L
	USB	H	H	L	L	L	L	L	L
10 MHz	CW	L	L	L	L	L	L	L	L
-20 MHz	LSB	H	L	H	L	L	L	L	L
	USB	H	H	L	L	L	L	L	L

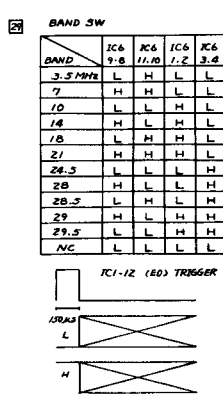
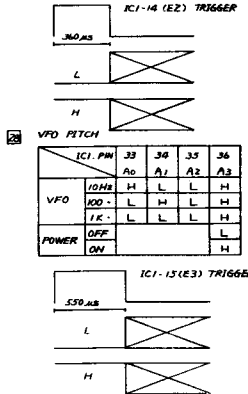

IC-730

EF UNIT

■ RIT BOARD

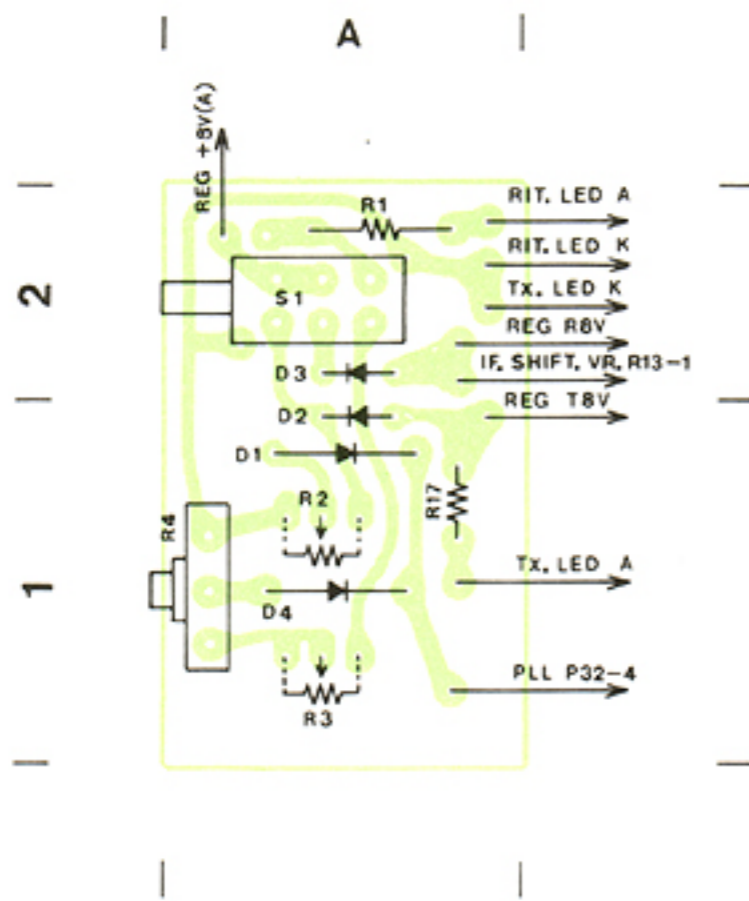

■ M SW BOARD

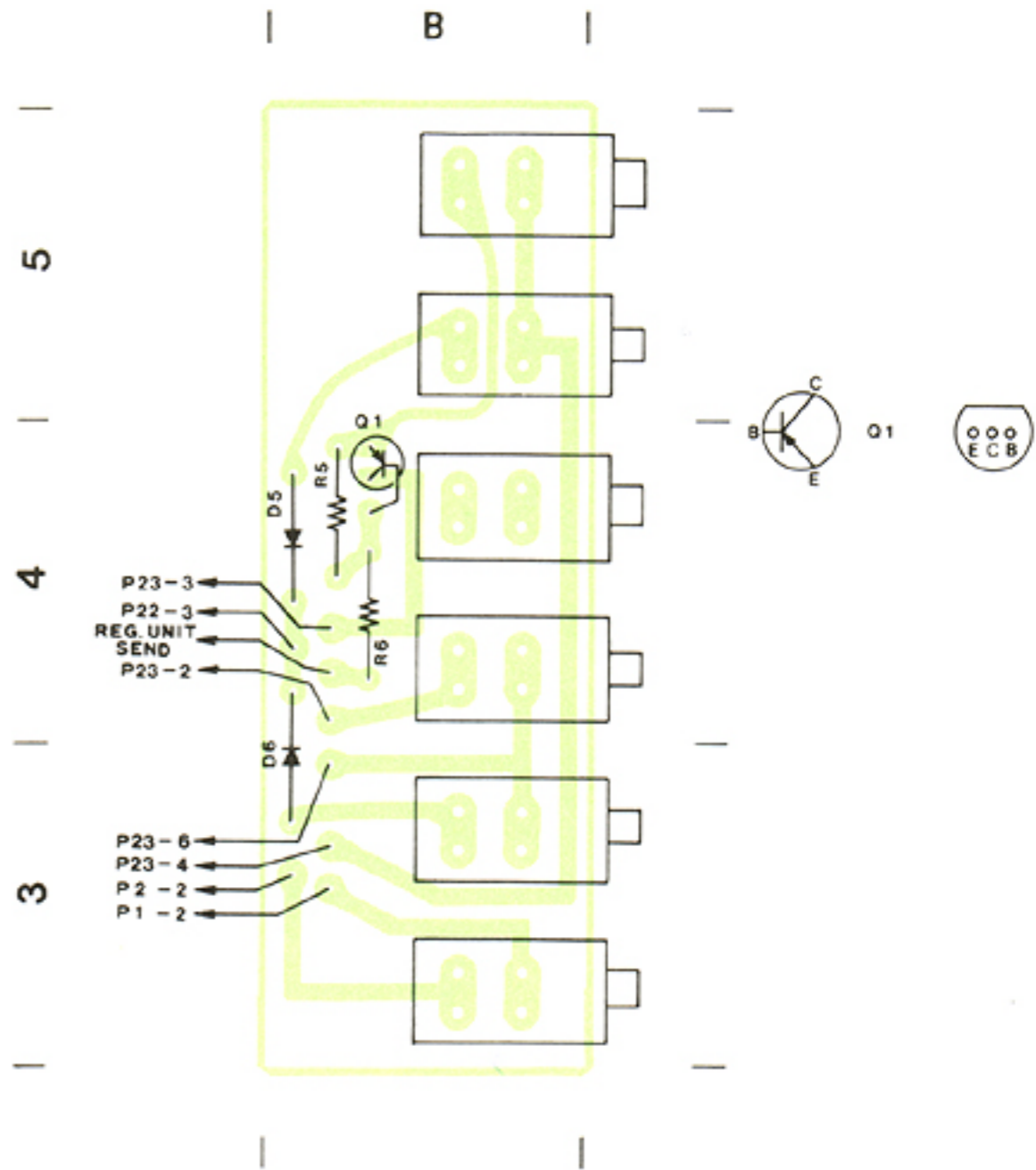

BOARD LAYOUT

117

■ DISPLAY BOARD

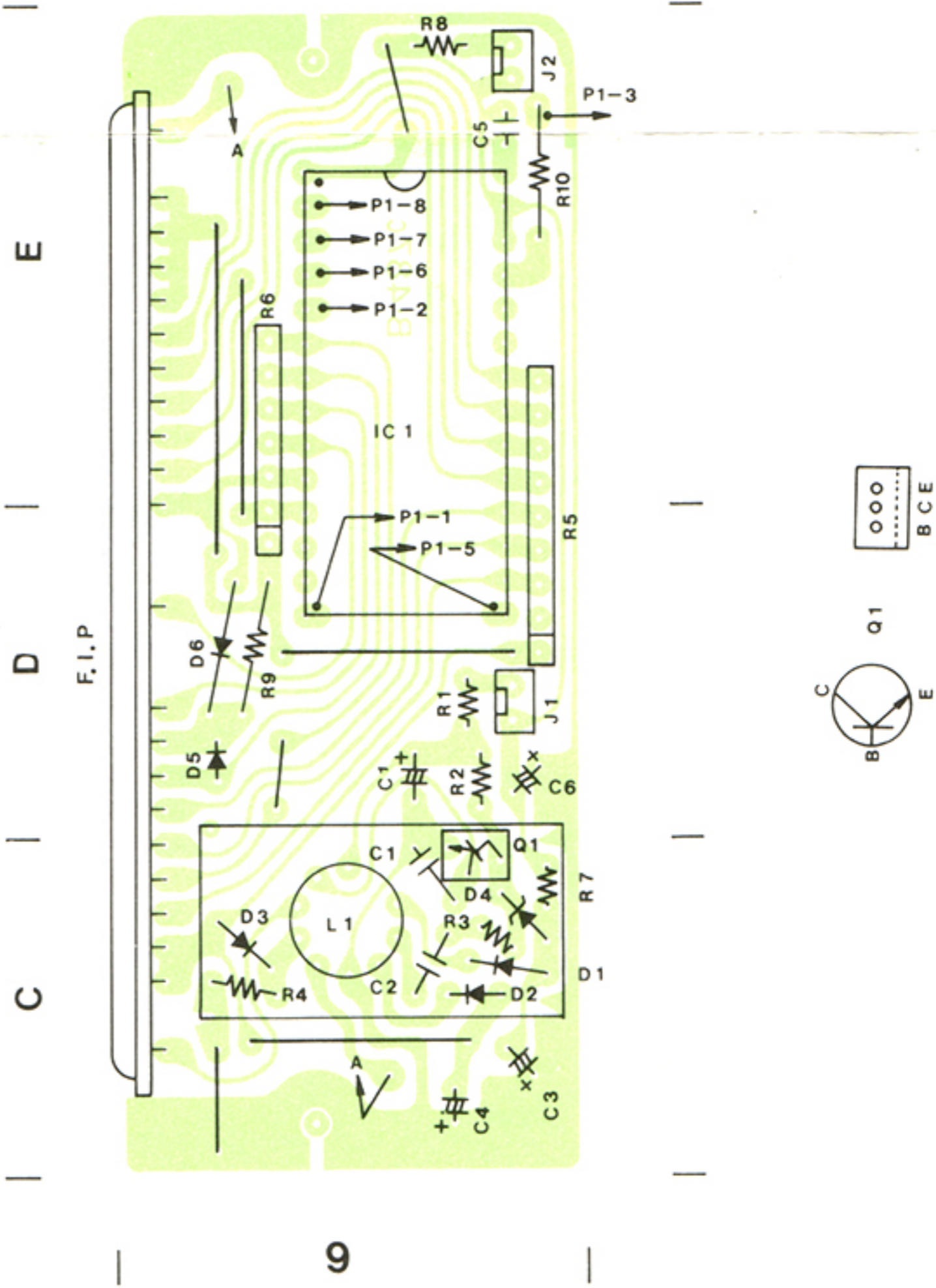

■ F SW BOARD

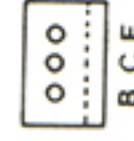
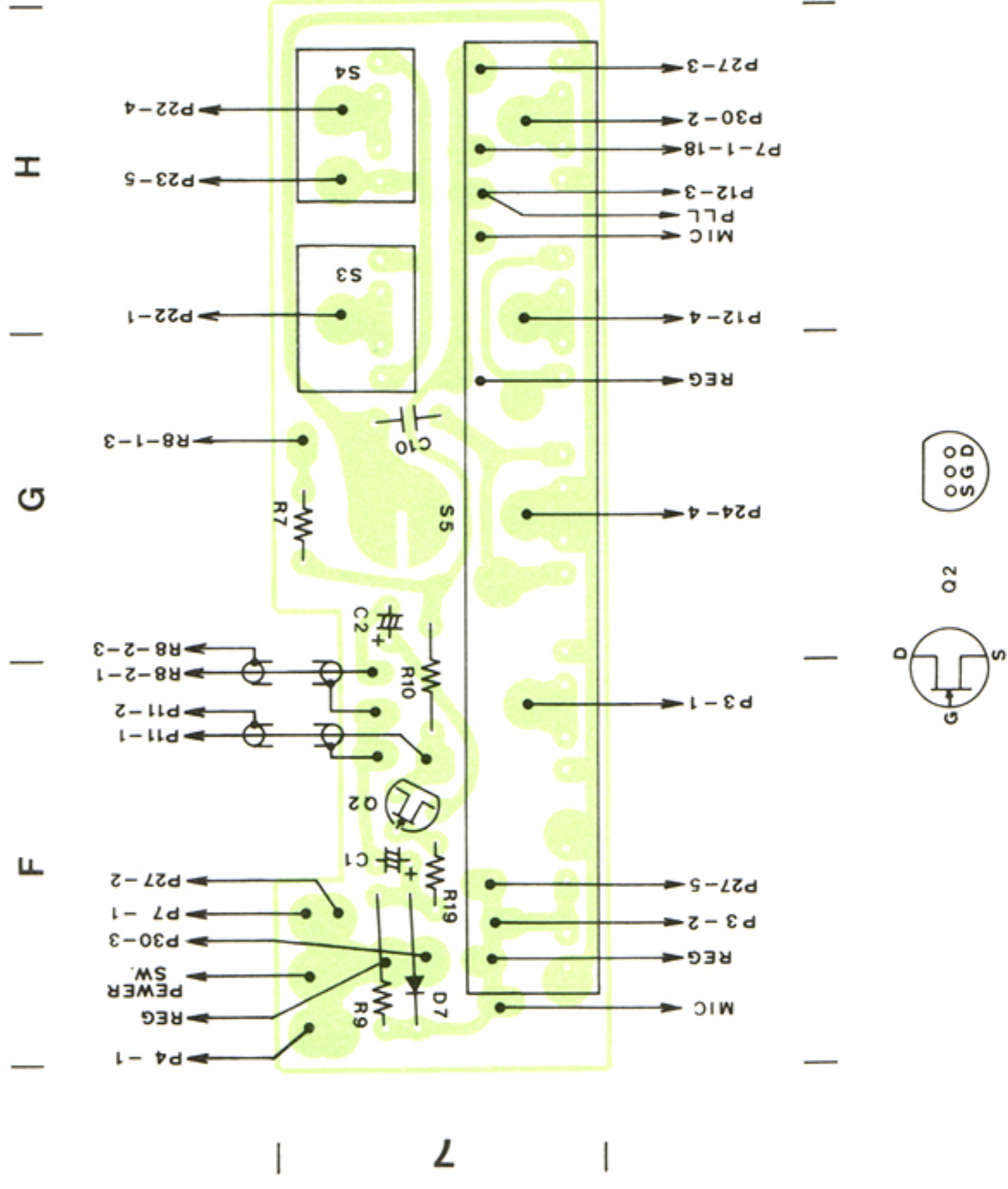

O 2





ICOM

■ SENSOR BOARD

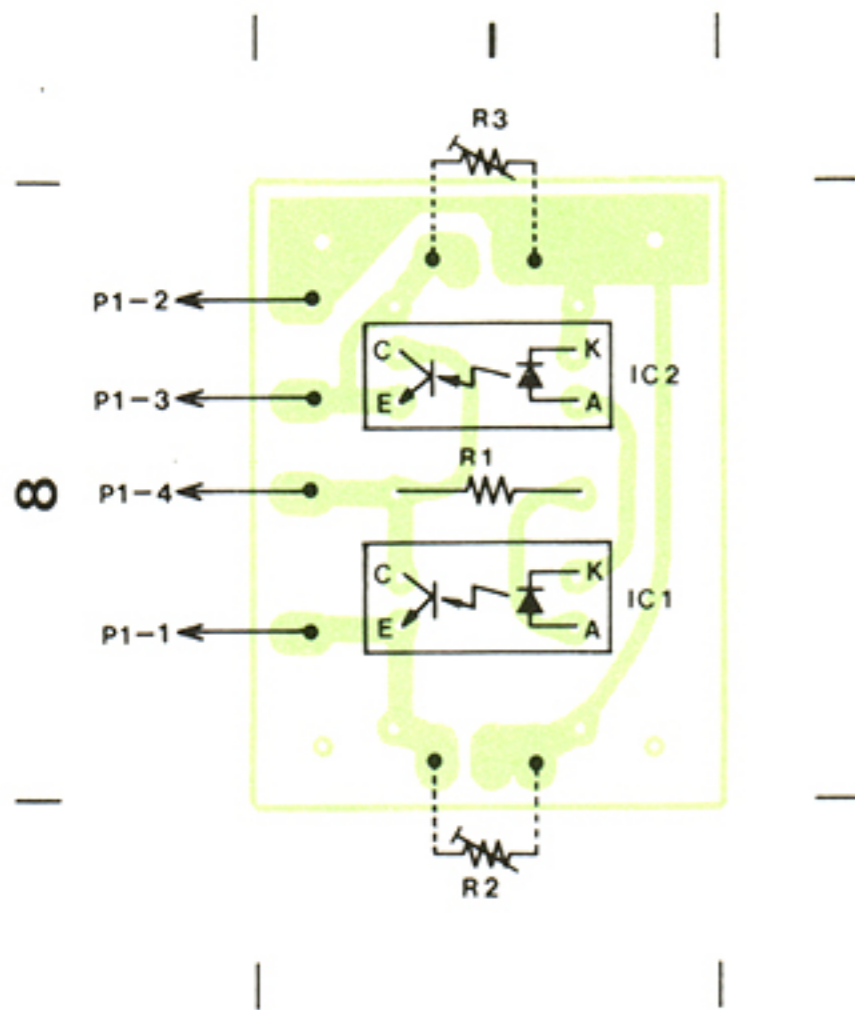

■ MIC BOARD

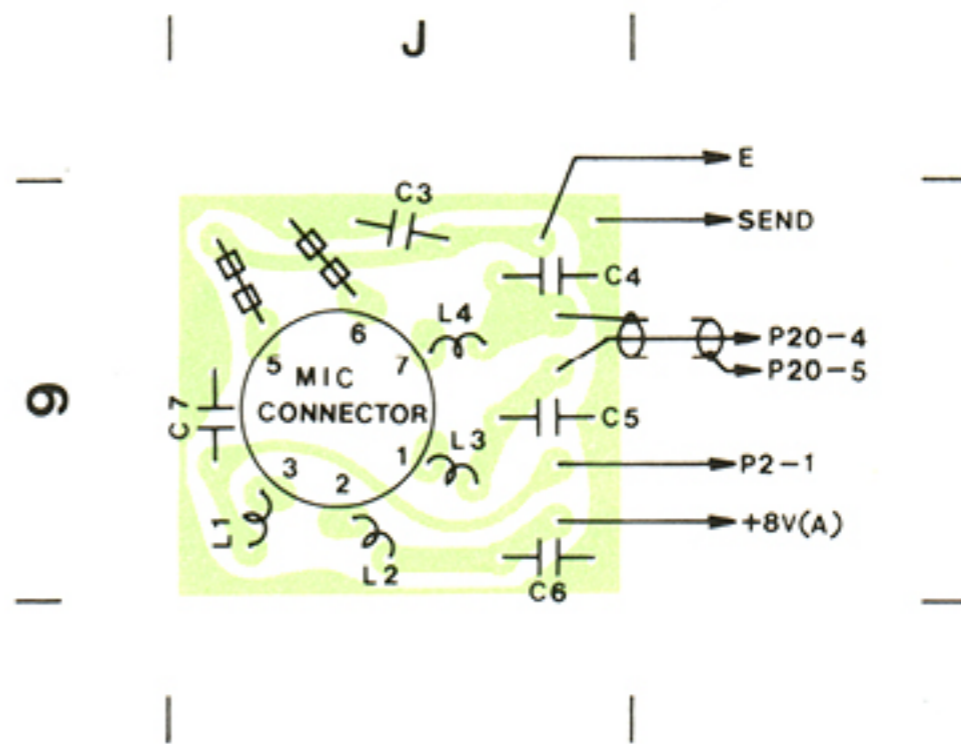

RF UNIT

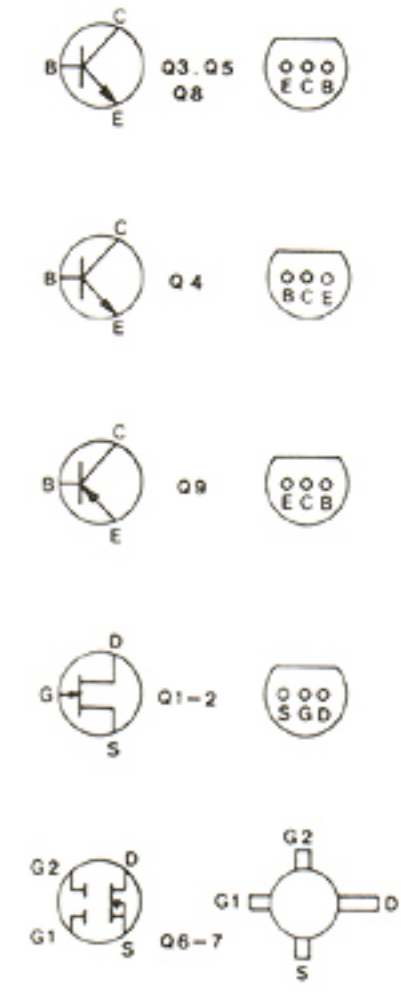
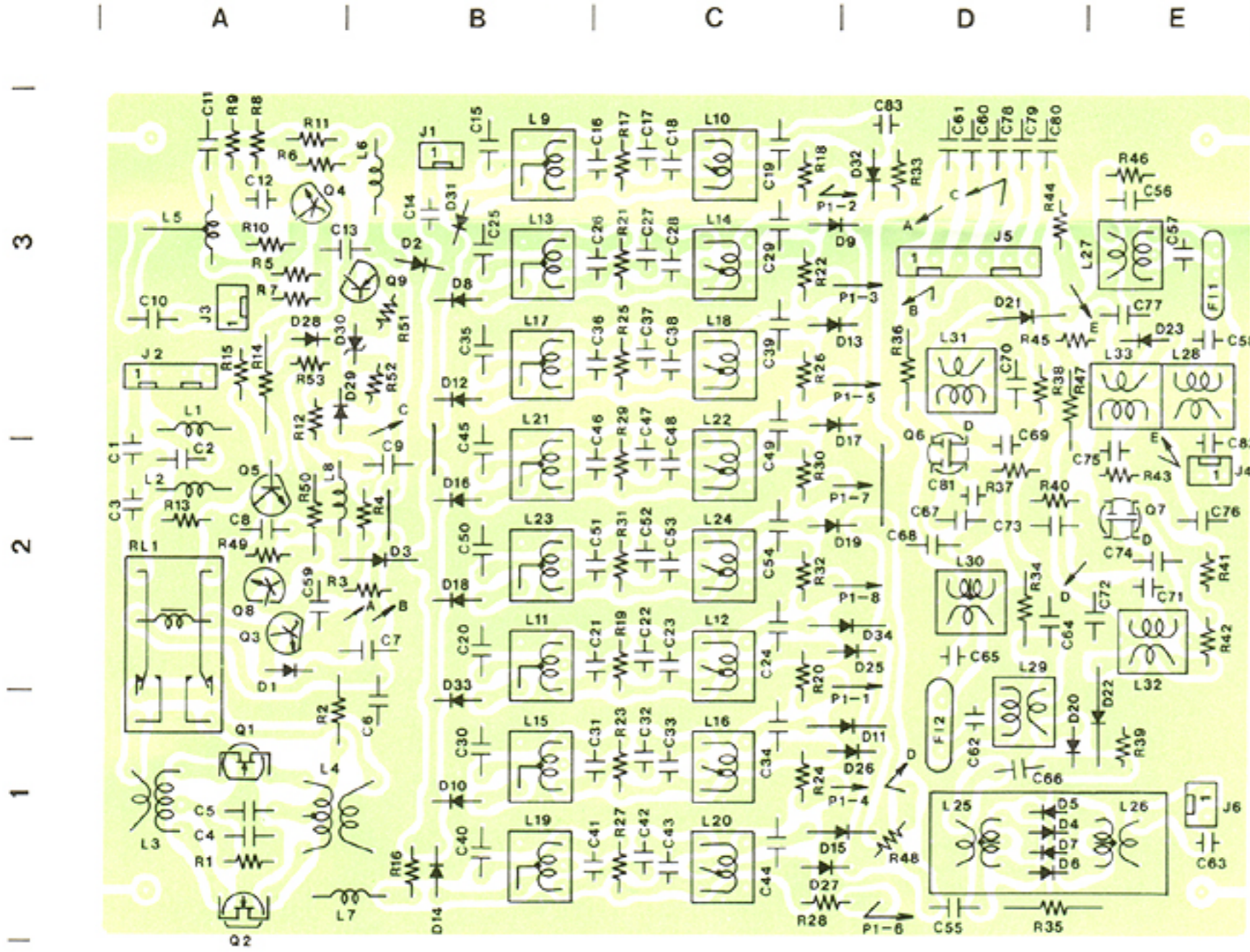

DETECTOR UNIT

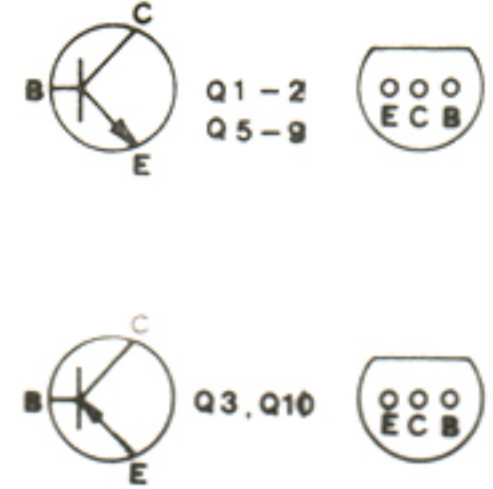
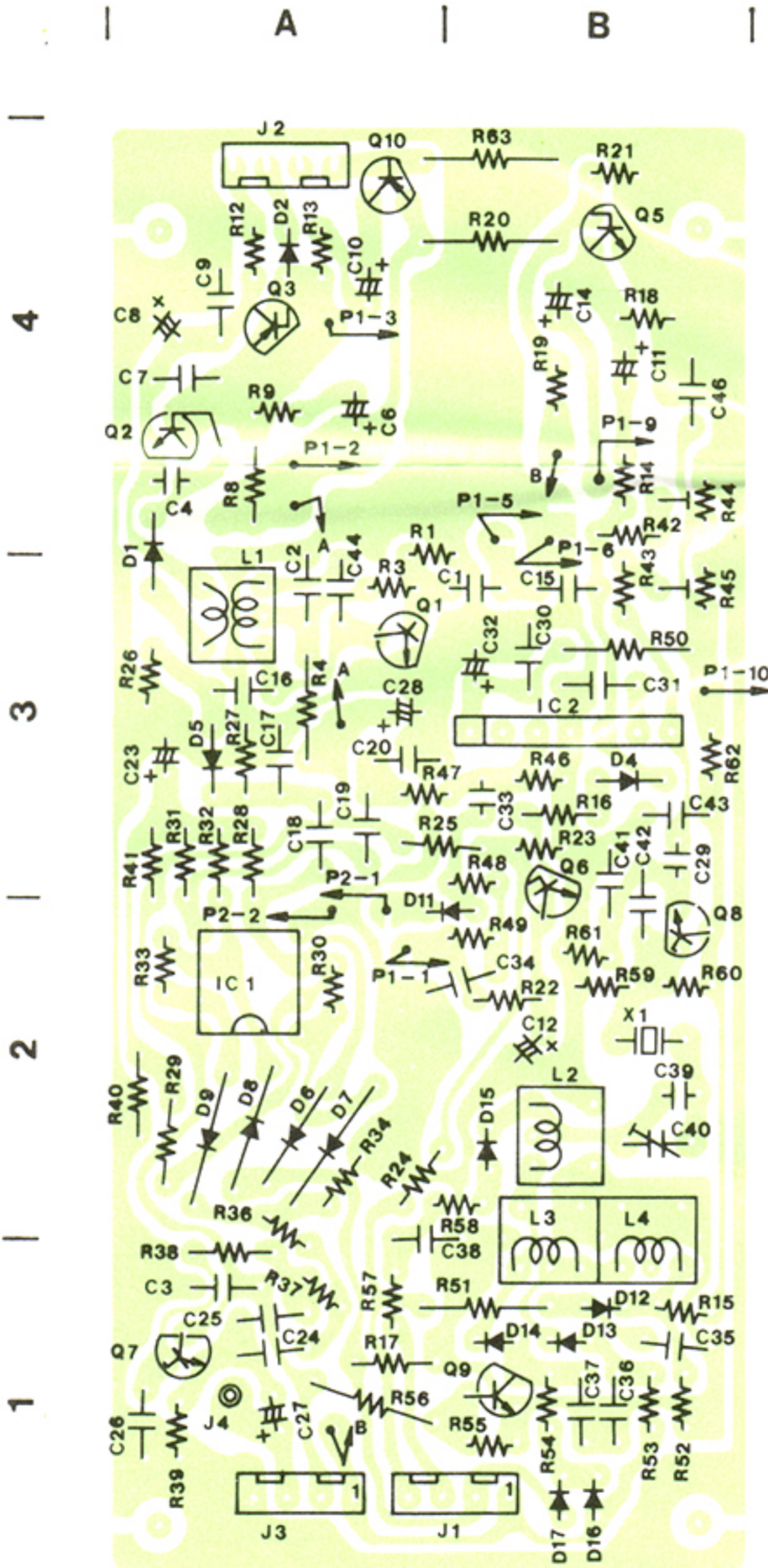

MAIN UNIT

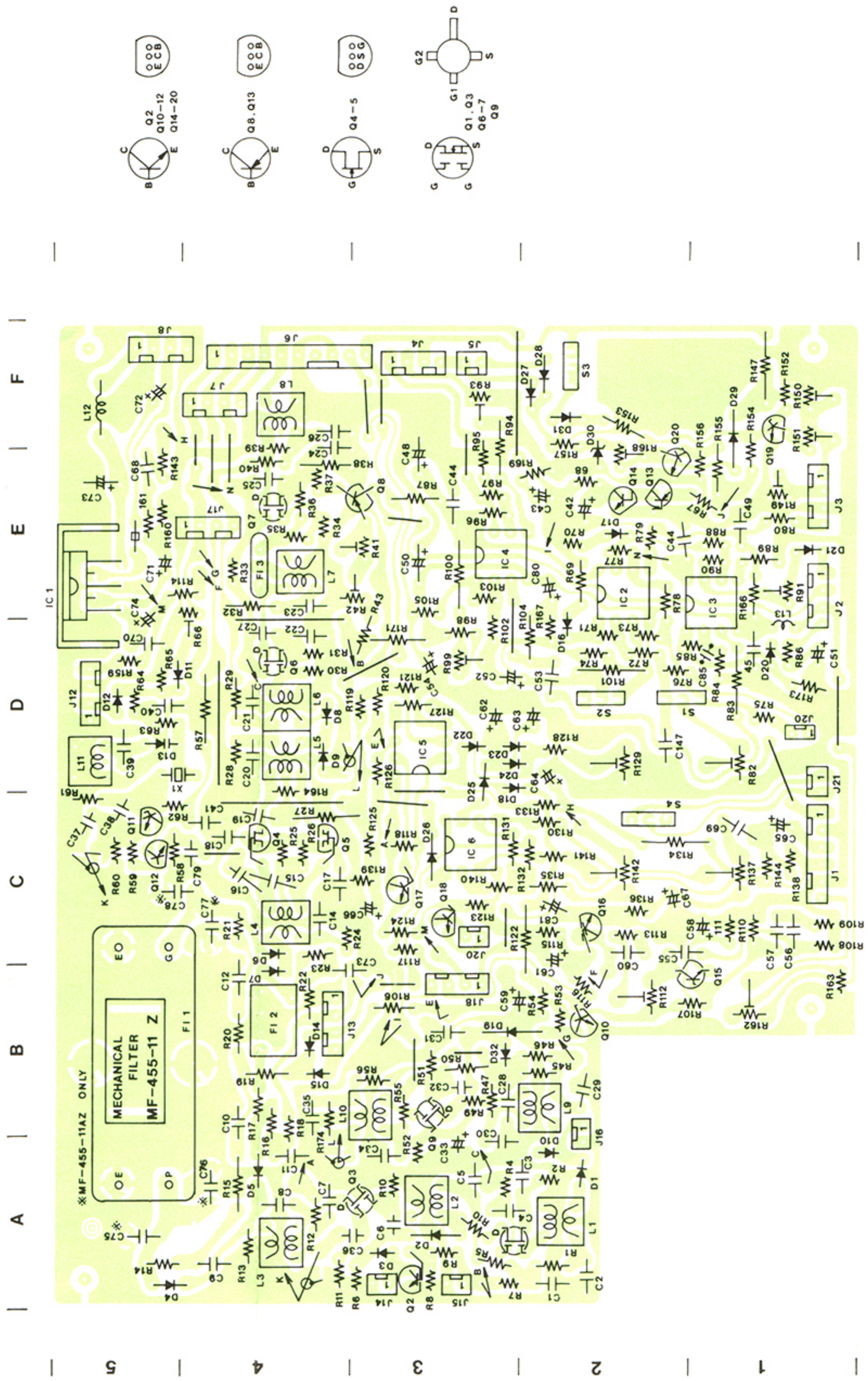

LOGIC UNIT

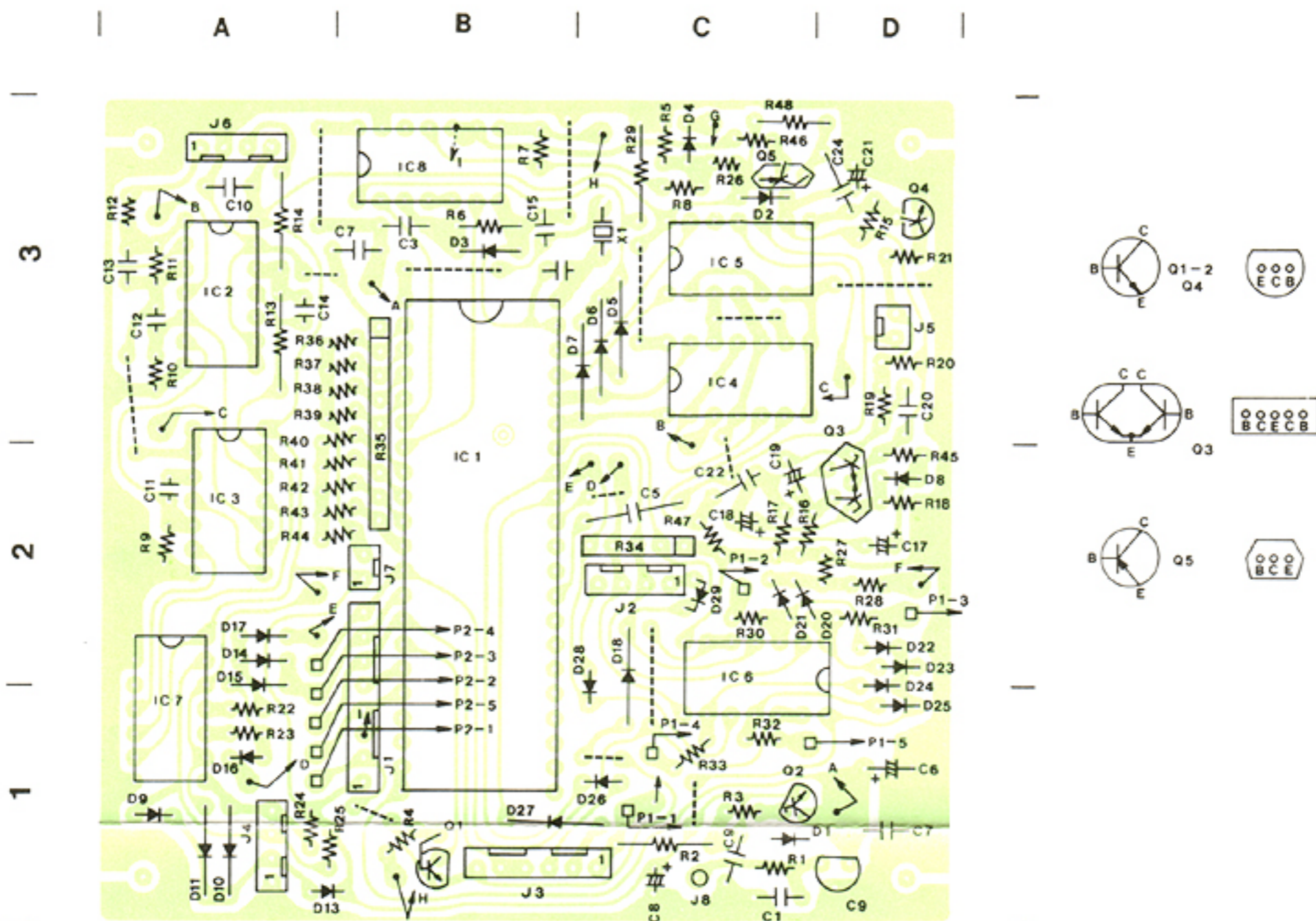

2nd IF UNIT

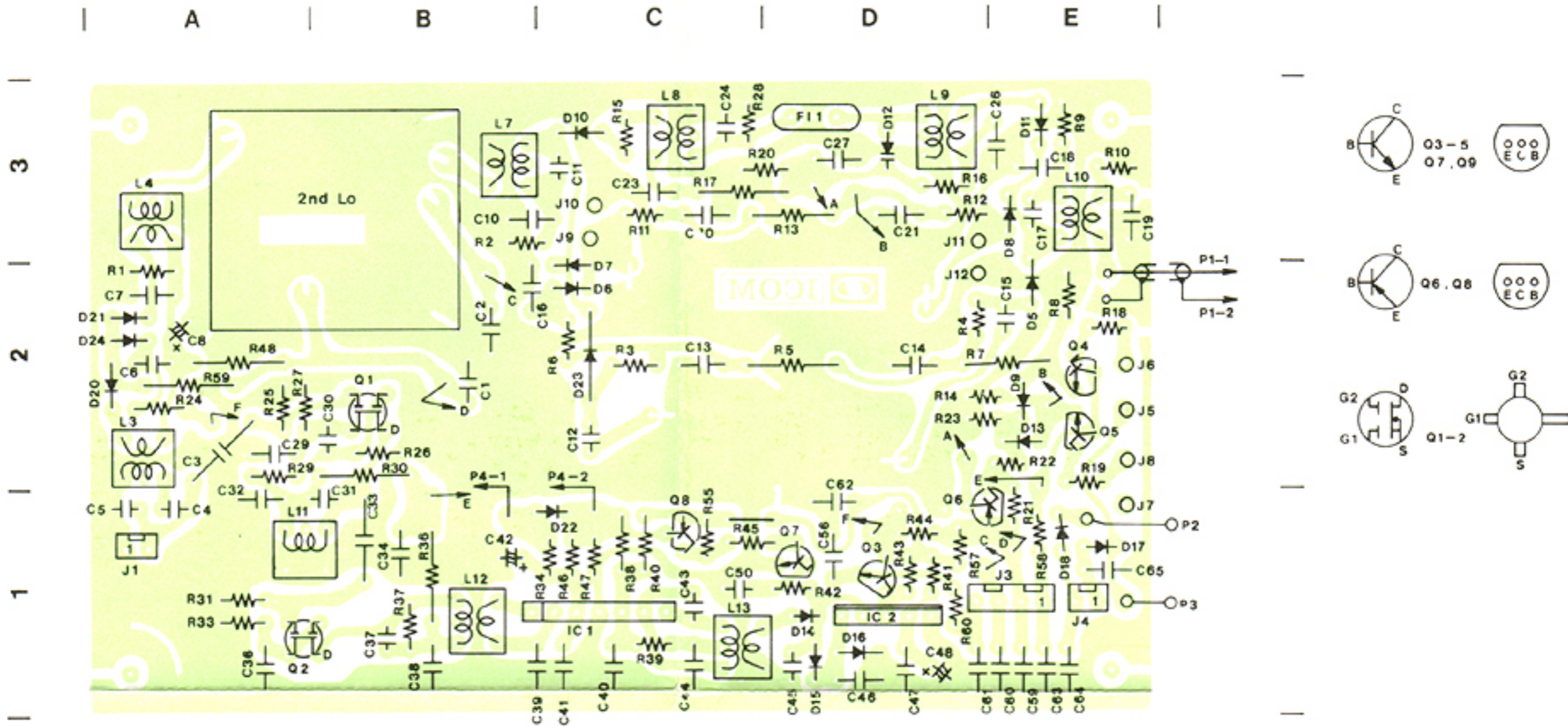

2nd LO UNIT

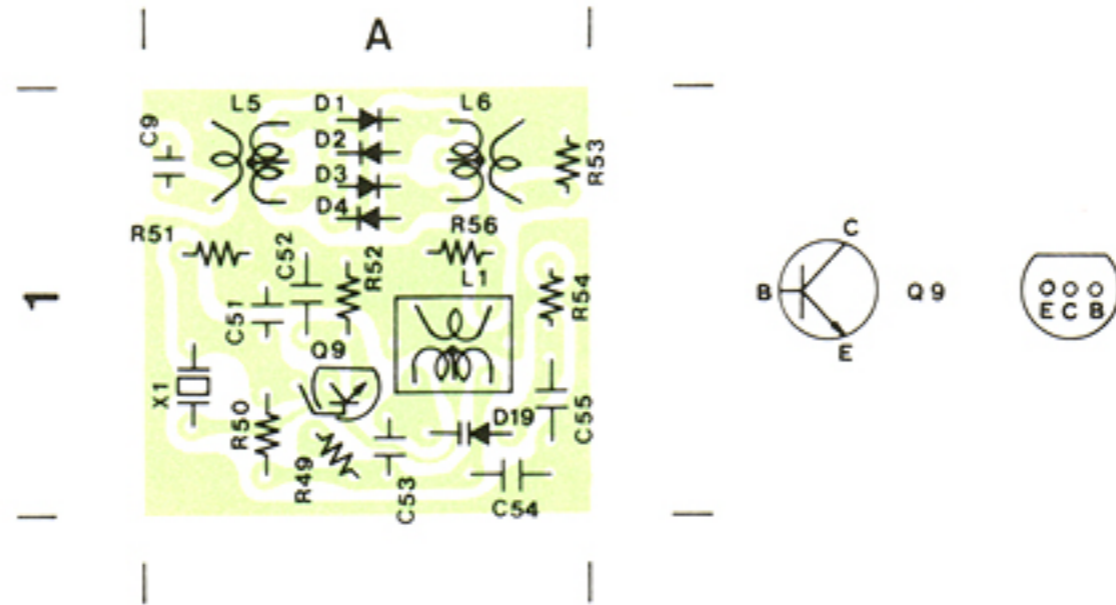

PLL UNIT

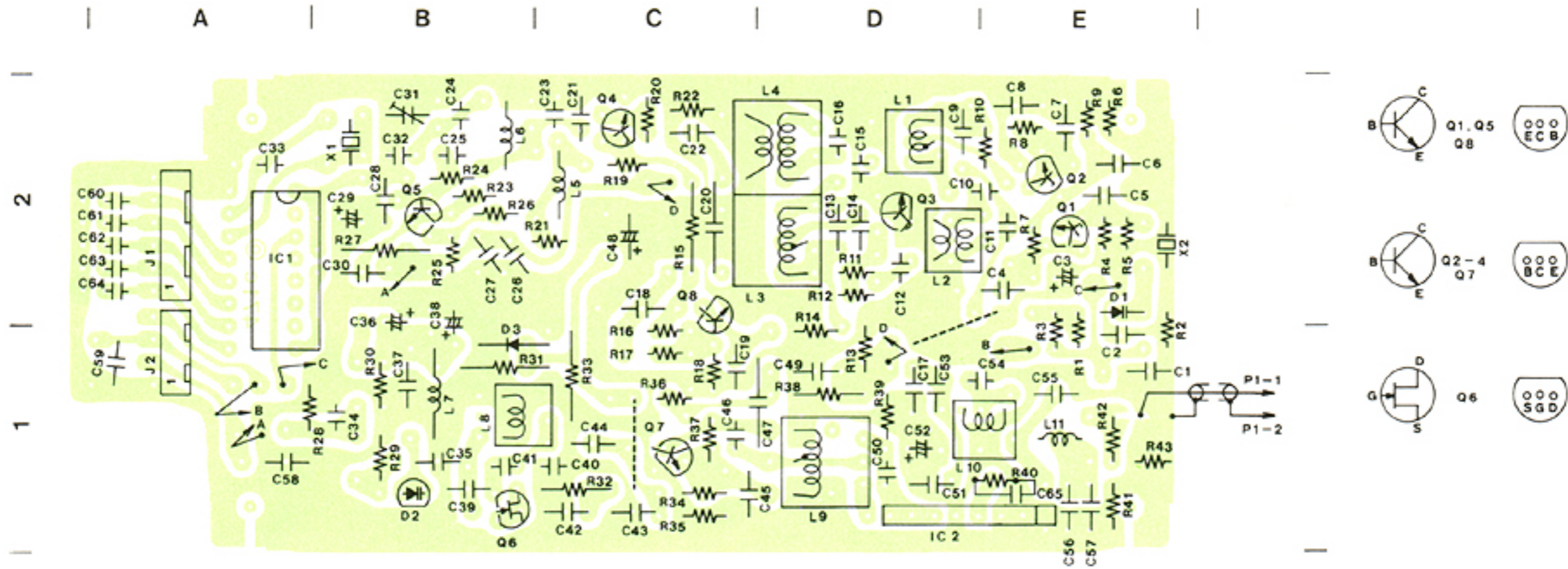

PREMIX UNIT

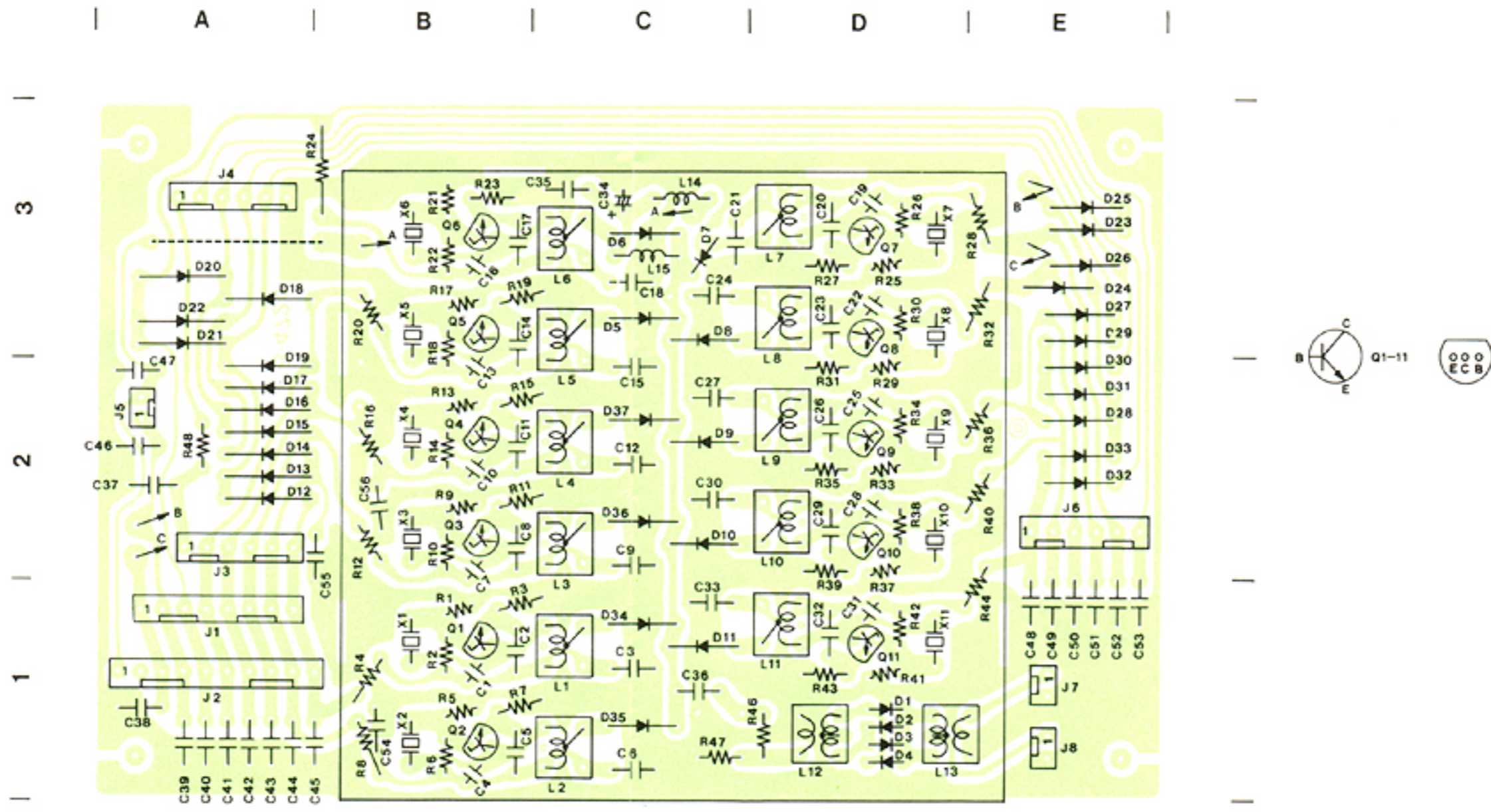

BPF UNIT

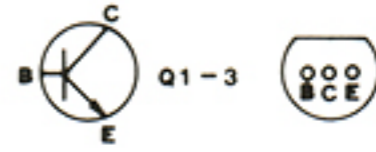
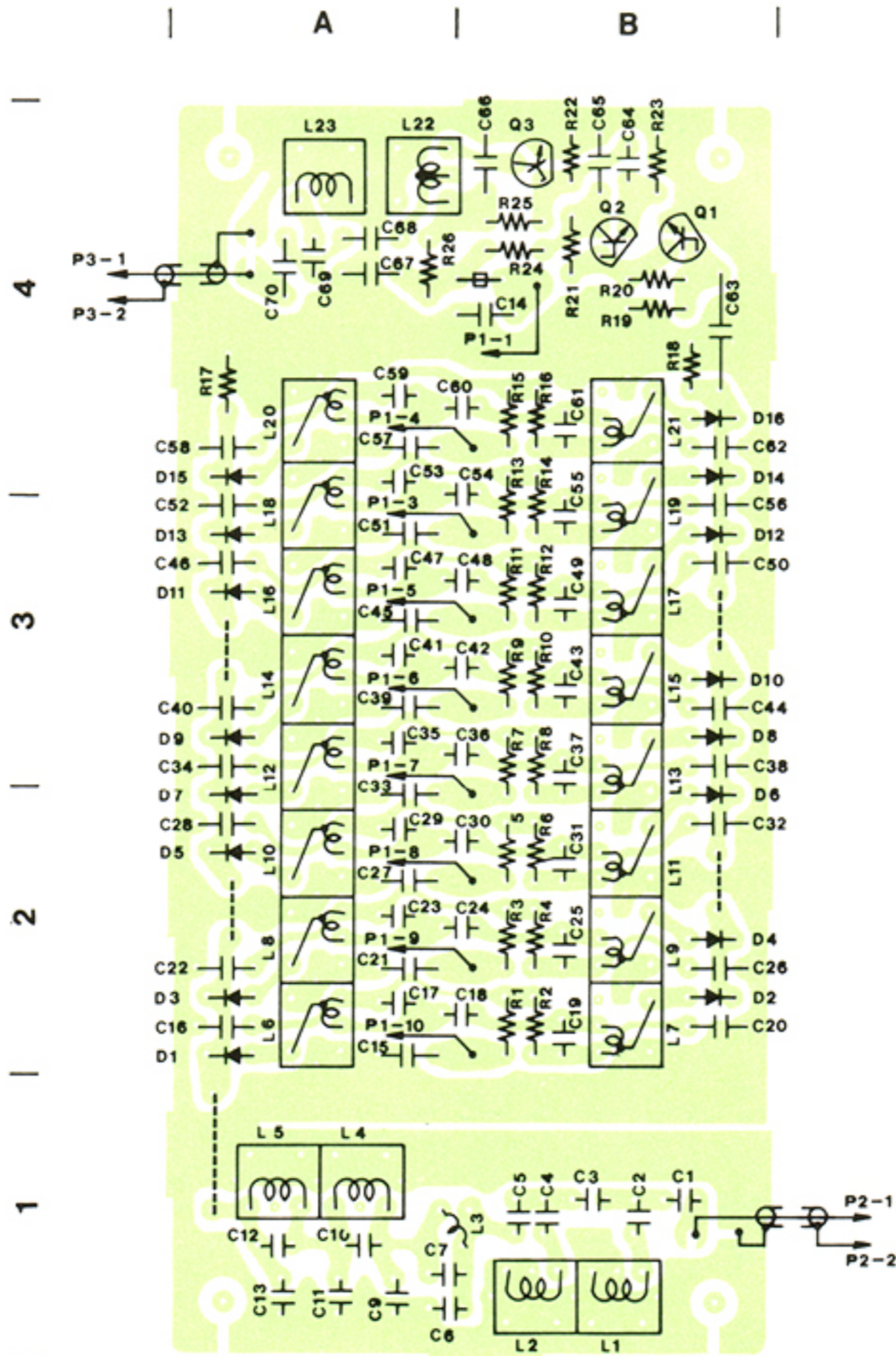

FILTER UNIT

A | B | C | D | E | F | G

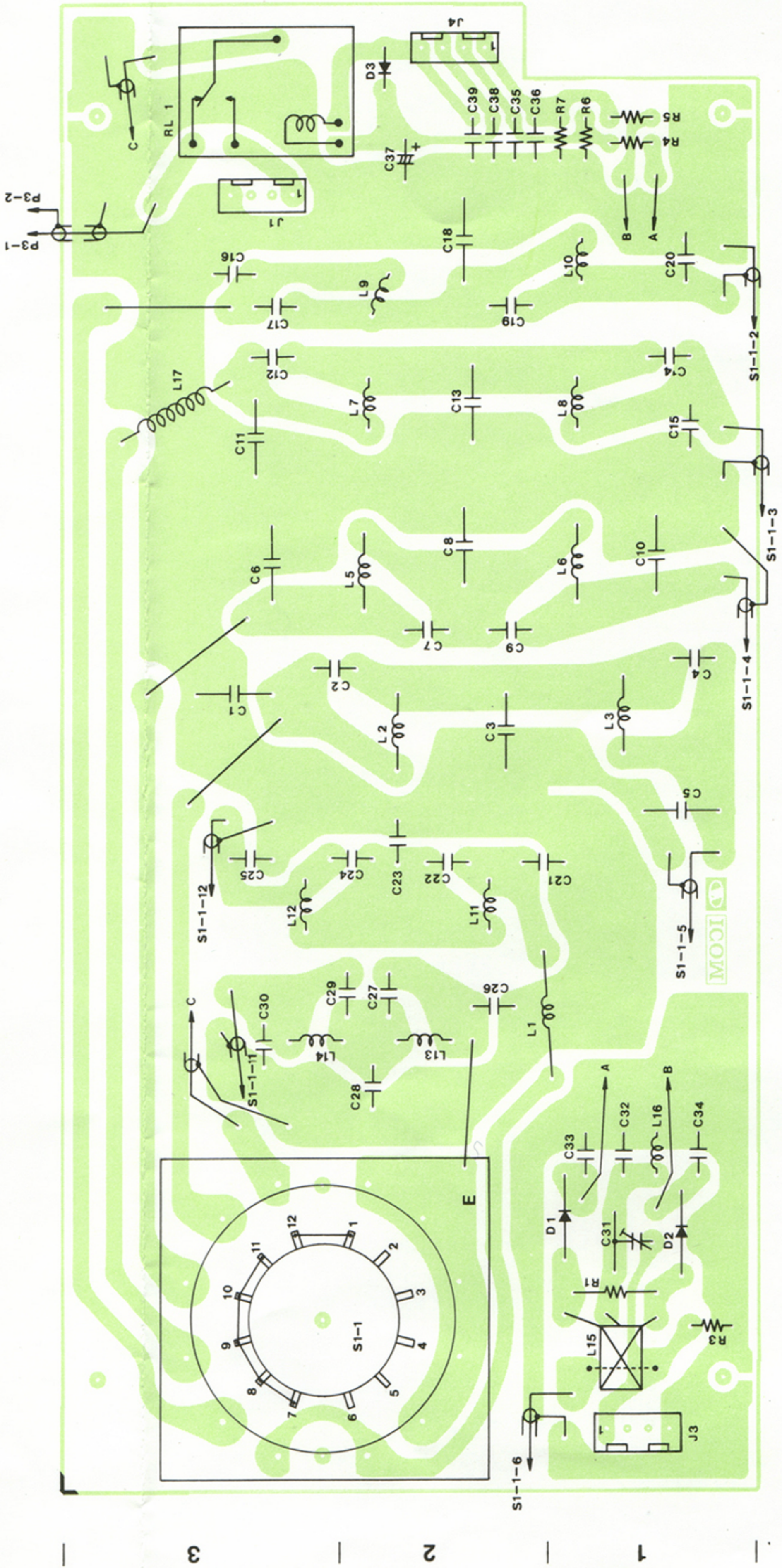

ACC UNIT

A

B

3

2

1

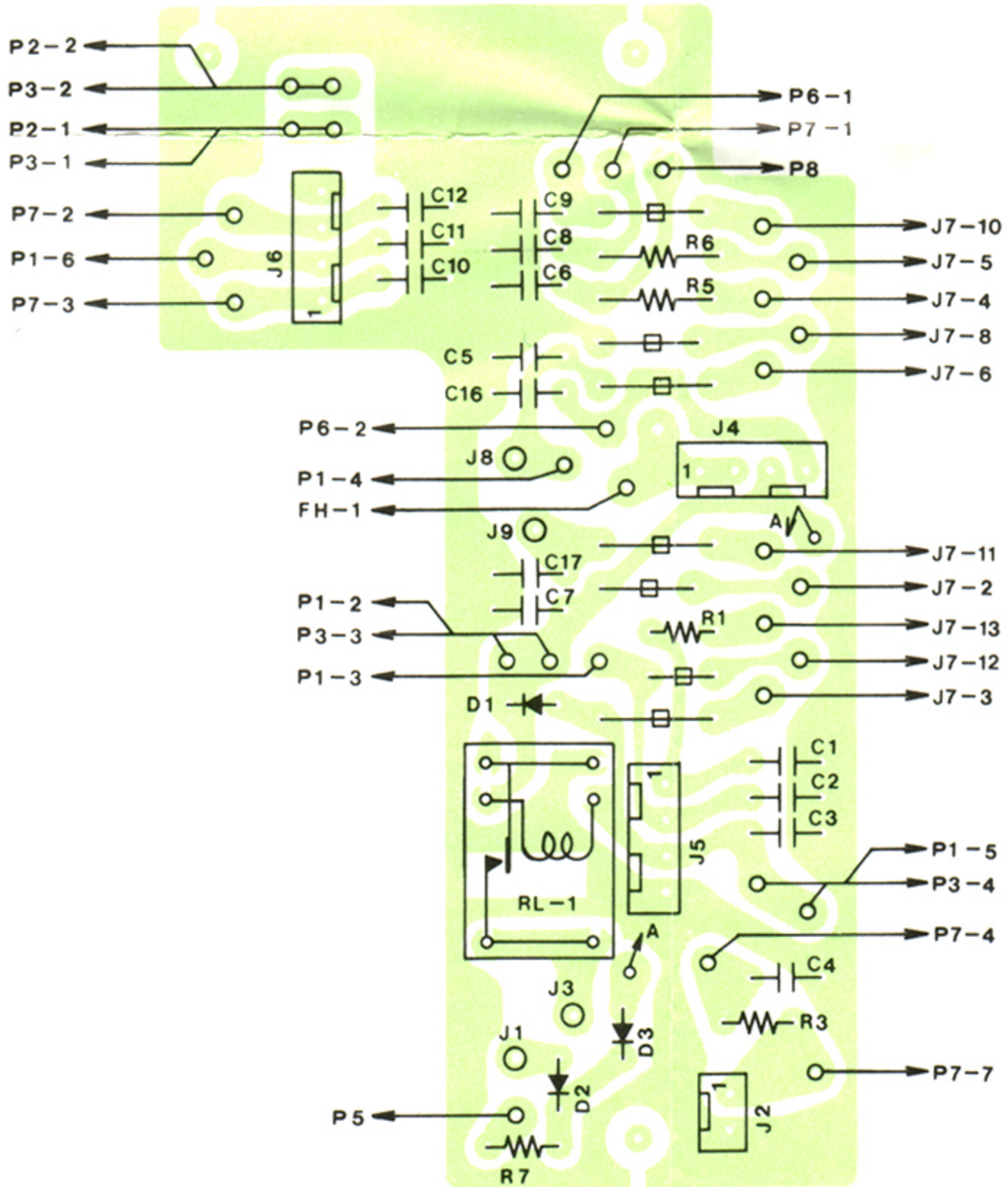

PA UNIT

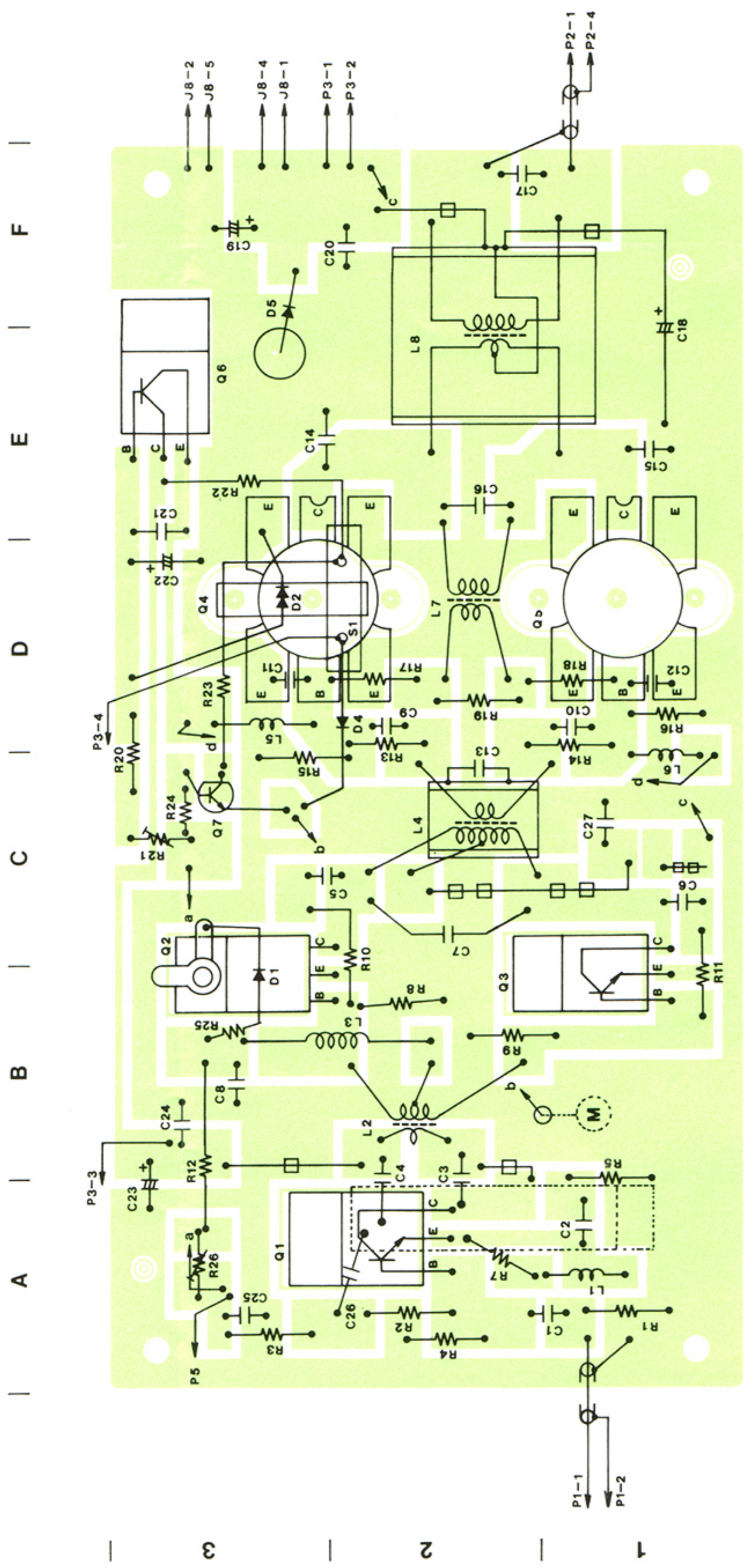

REGULATOR UNIT

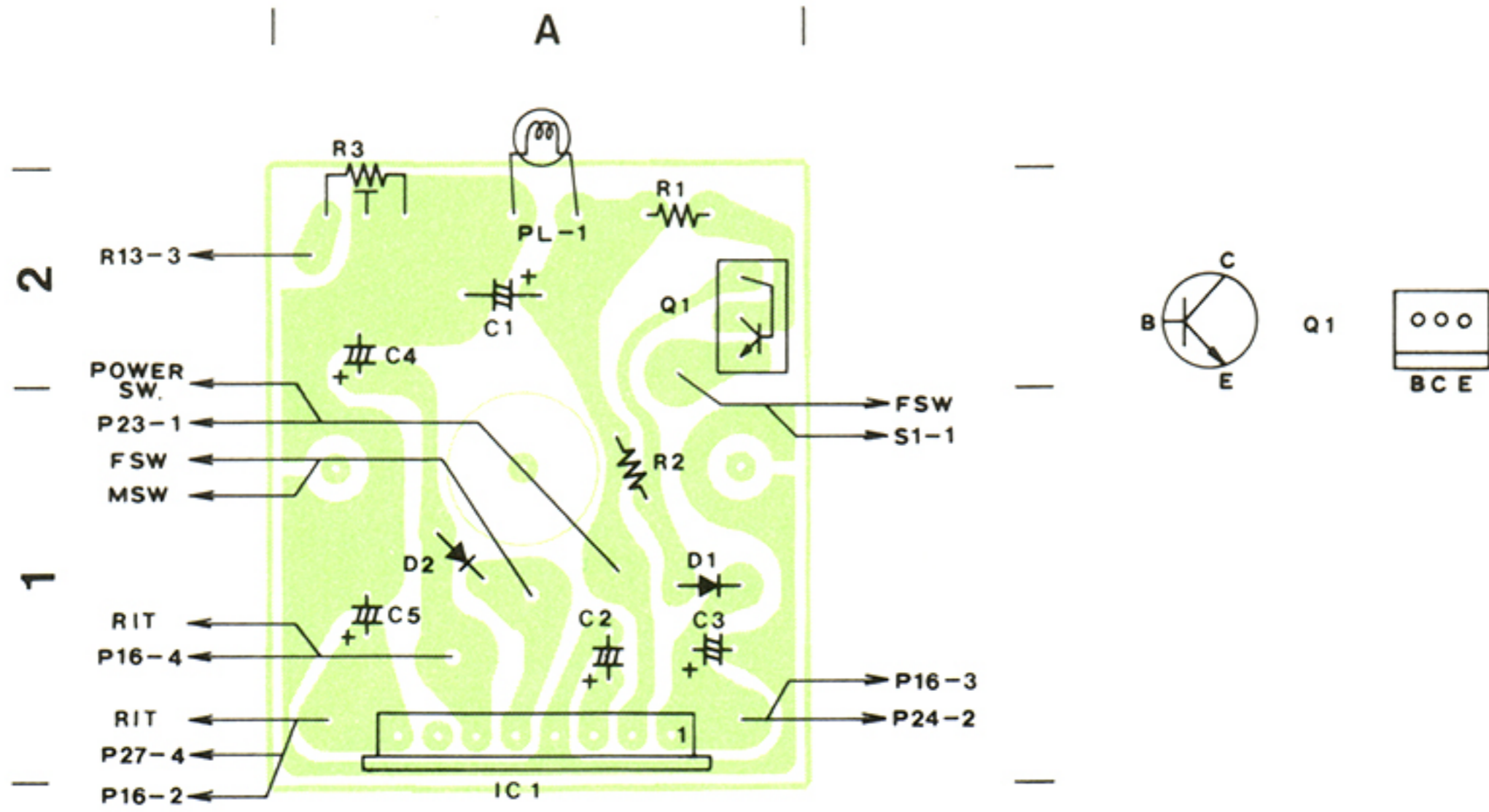

UNIT LAYOUT

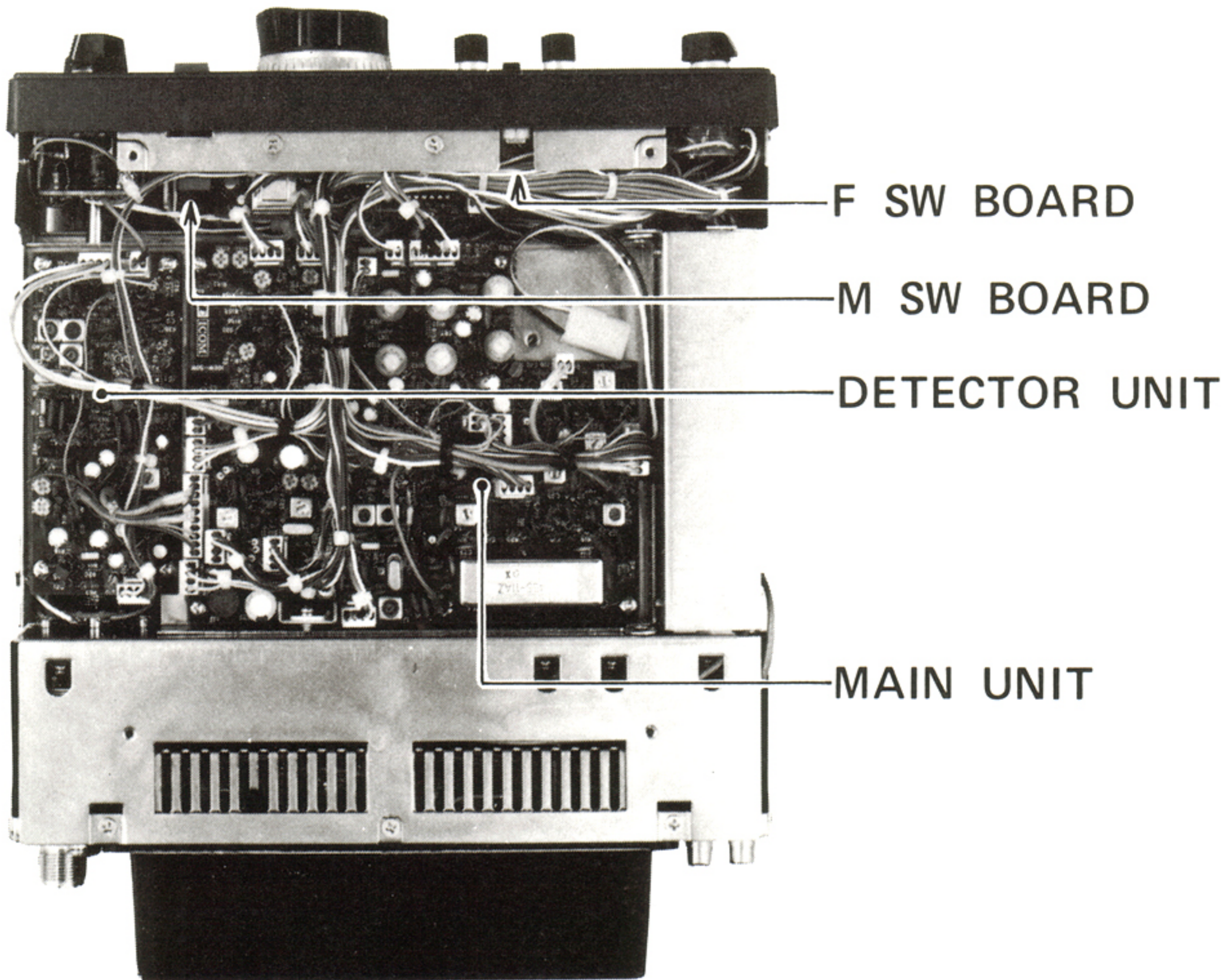

REGULATOR UNIT

2nd LO UNIT
DISPLAY BOARD

LOGIC UNIT

2nd IF UNIT

FILTER UNIT

ACC UNIT

PA UNIT

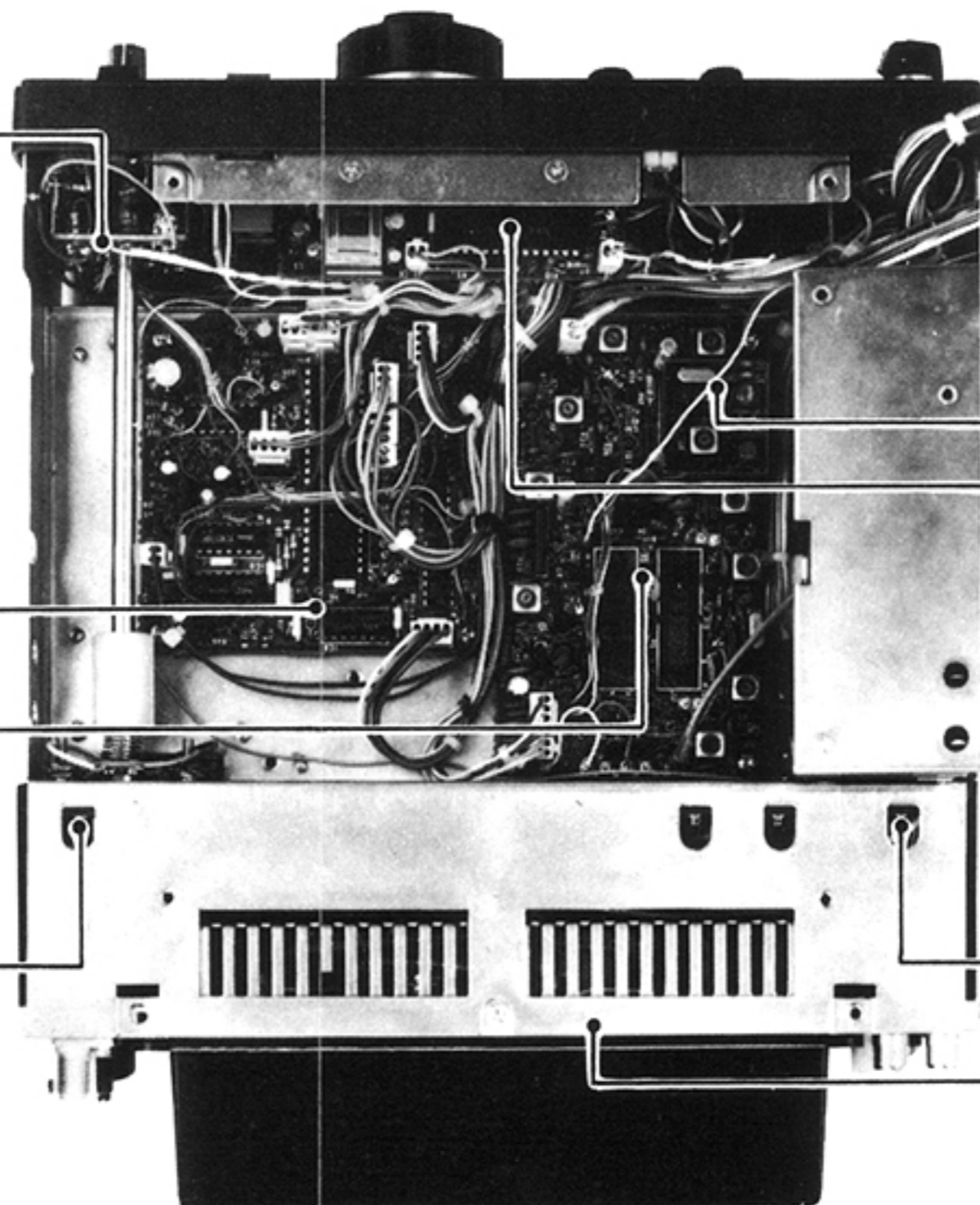

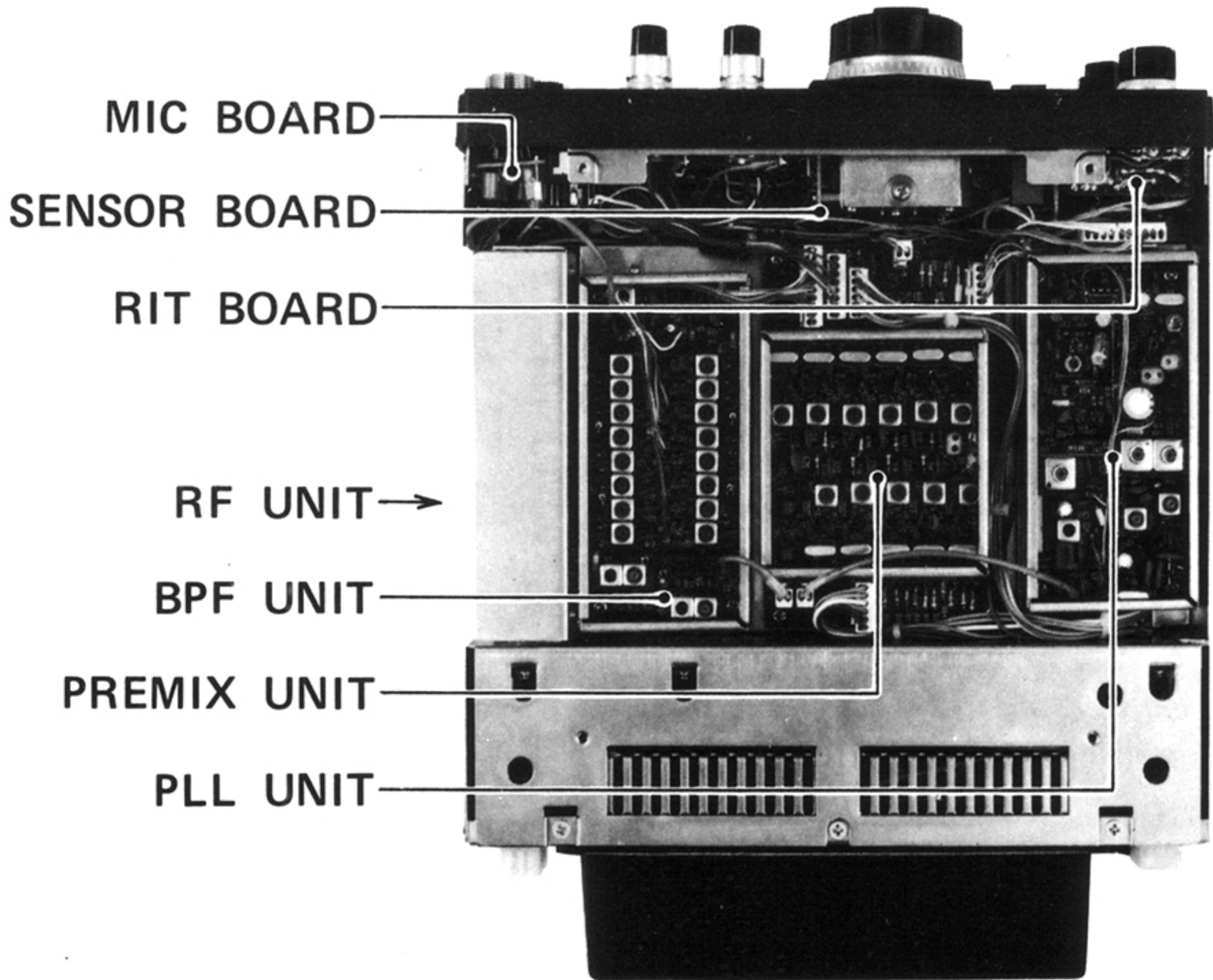



ICOM INCORPORATED

Some components subject to change
for an improvement without notice.